

# Power Factor Improvement by Harmonic Reduction in Power System

M.Sumitha, R.Sujatha, A.Jamna



**Abstract:** The load with a poor power factor speeds up the flow of electrons when compared to the load with high power factor in the electrical power systems. The current extracted from the system is distorted by non-linear loads. In this paper, to achieve active power factor correction Boost converter topology is utilized. The boost converter topology must meet two concurrent conditions: 1) the boost converter's input value must be set lesser than the output voltage value and 2) the voltage at any point of time must be set in such a way that it is always proportional to the current. This scheme utilizes a positive output Luo converter which is connected to rectifier circuit to offset the harmonic current from the rectifier. This paper presents a new control scheme to accomplish a power factor closer to unity.

**Keywords:** Non-Linear Loads, Power Factor Correction, Positive output Luo converter.

## I. INTRODUCTION

The demand for the electric power increase drastically everywhere leading to the consumption of fossil fuels and other conventional, non-conventional energy resources. Due to the variation in temperature and climate it is impossible to completely rely on the renewable energy resources to satisfy the energy demand. The global ventures and Research and Development endeavour is centred on decreasing sustainable power source generation cost. DC – DC boost converters help in improving the proficiency of overall sustainable power system. Most of power sources are used to deliver the power at the voltage ranging from 12VDC to 70VDC. In order to meet the grid requirements, the resultant voltage must be increased or boosted to a range of around 200VDC or 400VDC depending on the grid requirements. Depending on the voltage levels and applications, the converter topology can be selected.

## II. WHY TO IMPROVE THE POWER FACTOR?

There are numerous causes in oration of the concept of poor power factor. Some of them are as follows. Depending upon the I<sup>2</sup>R losses the customer is penalized up to 20-40% of the Demand charges for not maintaining the power factor within the limits or for maintaining power factor. Also in order to improve the system capacity, efficiency and the life of the equipments at the generating stations we are in need to improve the power factor within the advisable range. A good power factor improves the system efficiency, output and cost and life of the equipments.

Revised Manuscript Received on February 05, 2020.

\* Correspondence Author

M.Sumitha, M.E. degree, SSN College of Engineering, Chennai.

R.Sujatha, M.E degree, St.Joseph's College of Engineering, Chennai.

A.Jamna, Doctorate degree, Anna University, Chennai

© The Authors. Published by Blue Eyes Intelligence Engineering and Sciences Publication (BEIESP). This is an open access article under the CC BY-NC-ND license (<http://creativecommons.org/licenses/by-nc-nd/4.0/>)

## III. ANALYSIS OF SIMPLE RECTIFIER CIRCUIT WITH MODIFIED CIRCUIT

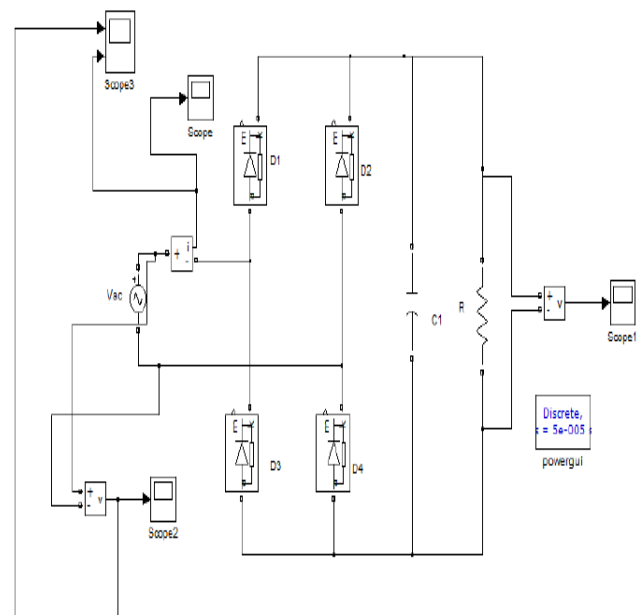


Fig1. Circuit Diagram of the Rectifier

Fig1. show the circuit diagram of the rectifier. Initially, AC power is rectified by bridge diodes. Current flowing is in phase with input voltage; however, the waveform of the line current is not sinusoidal. From the waveform shown in Fig2, it is inferred that the system is rich in harmonics which will generate additional heat and create damage to the system. The presence of excessive harmonics arise electrical noise leading to interference with the performance of systems.

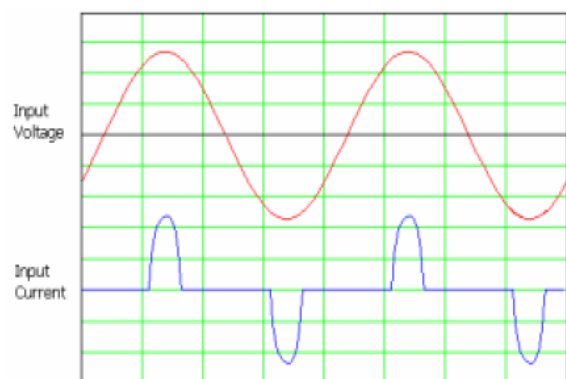
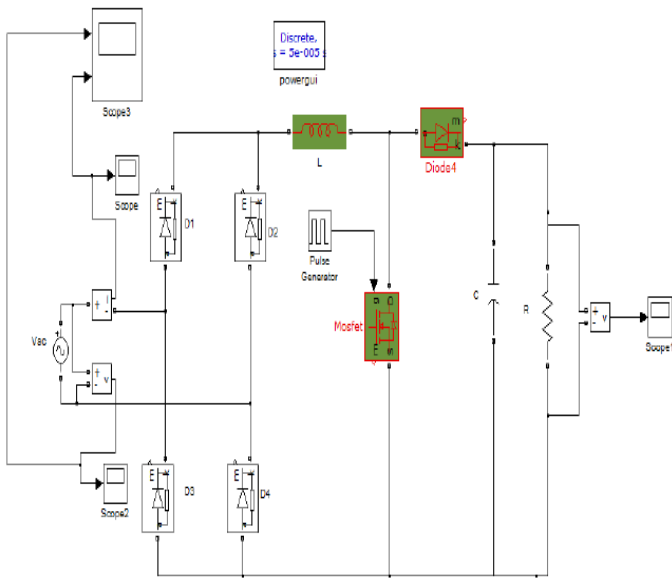


Fig2. Input Current Voltage of rectifier circuit

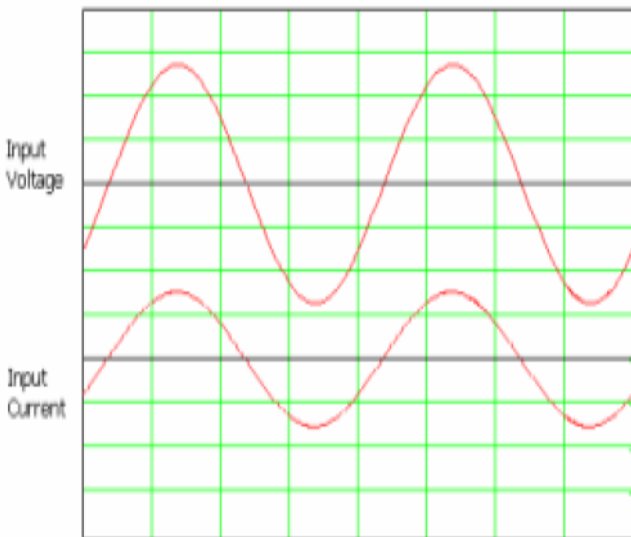
## IV. MODIFIED RECTIFIER CIRCUIT:





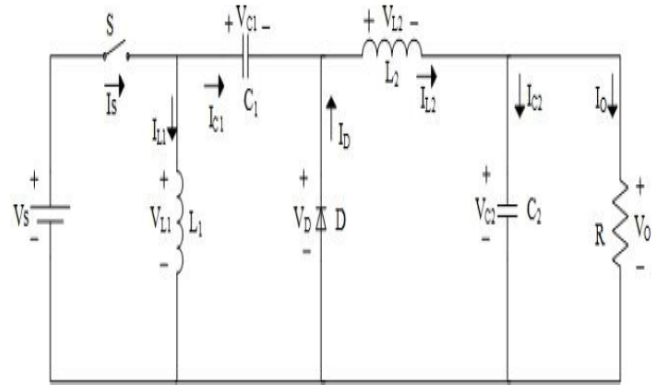
**Fig3. Circuit diagram of Modified Rectifier**

Fig3 shows the circuit diagram of modified rectifier that includes the Inductor L1, diode D1 and the power semiconductor switching device ie. the MOSFET along with the control circuitry are present. When the MOSFET is ON, the output power is delivered across the load through the diode and the capacitor bank. When the MOSFET is OFF, the energy stored in the storage device is sent back to the supply. Again the voltage is found to be in phase with the line current. Fig4 is compared with Fig3. Fig4 shows the waveform of the system which is less in harmonics and it is a power factor corrected system or power factor improved system. From Fig2 it is inferred that the system is high in harmonics with low power factor. Thus the harmonics is eliminated and the power factor is improved with the help of the modified rectifier circuit.



**Fig4. Input Current, Input Voltage of modified rectifier circuit**

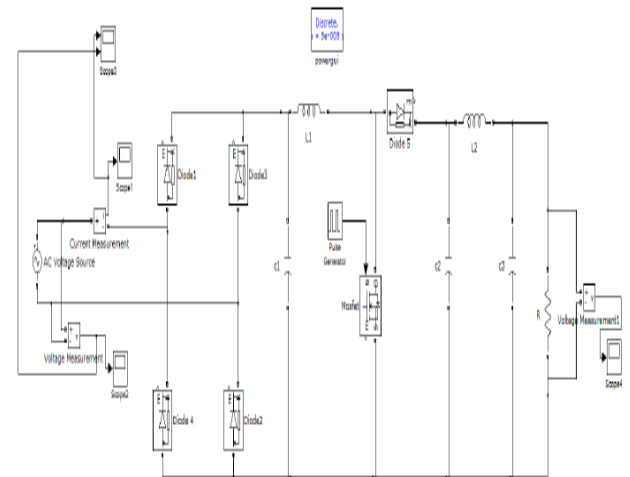
**V. CONVERTER USED IN PROPOSED SYSTEM**



**Fig5. Circuit diagram of voltage lift Luo Converter**

Fig5 shows the circuit diagram of the proposed system of voltage lift Luo converter. Luo converter is a DC-DC converter which accepts DC input and delivers DC output depending upon the voltage levels and applications. The term voltage lift means increase or raise of voltage levels. Most of the converters in the recent trends are featuring the voltage lift strategy in order to boost the voltage to a greater value when compared to the input voltage and to improve the gain of the system. Gain is the ratio of the output value to the input value. Gain of the system is increased in order to improve the efficiency and performance of the system. In our proposed topology positive output luo converter is used along with the modified rectifier circuit to achieve good power factor and to reduce the total harmonic distortions in the system. Depending upon the application any converter topology can be selected.

**VI. PROPOSED SYSTEM OF RECTIFIER CIRCUIT WITH LUO CONVERTER:**

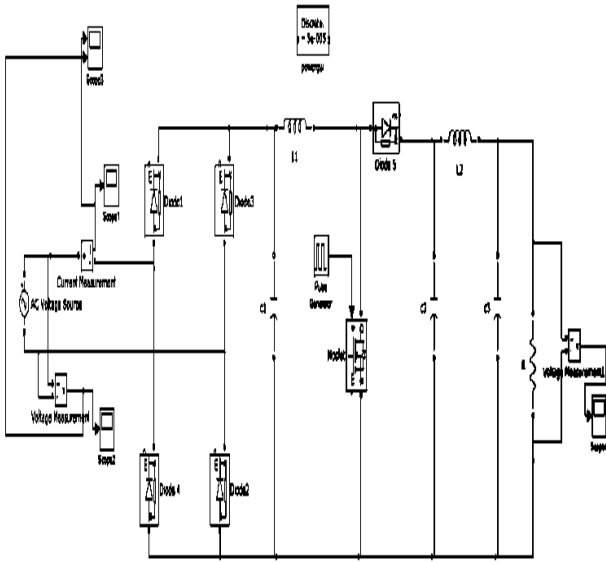


**Fig6. Proposed system rectifier circuit with Luo converter**

Fig6 shows the proposed system rectifier circuit with the luo converter. The front end of the converter has the modified rectifier circuit and the rear end has the positive super lift luo converter. The modified rectifier converts AC to DC. At that point the converted dc supply is allowed to pass through the luo converter. This positive voltage lift dc converter boosts the converted dc source. The resultant input voltage and current are in phase.

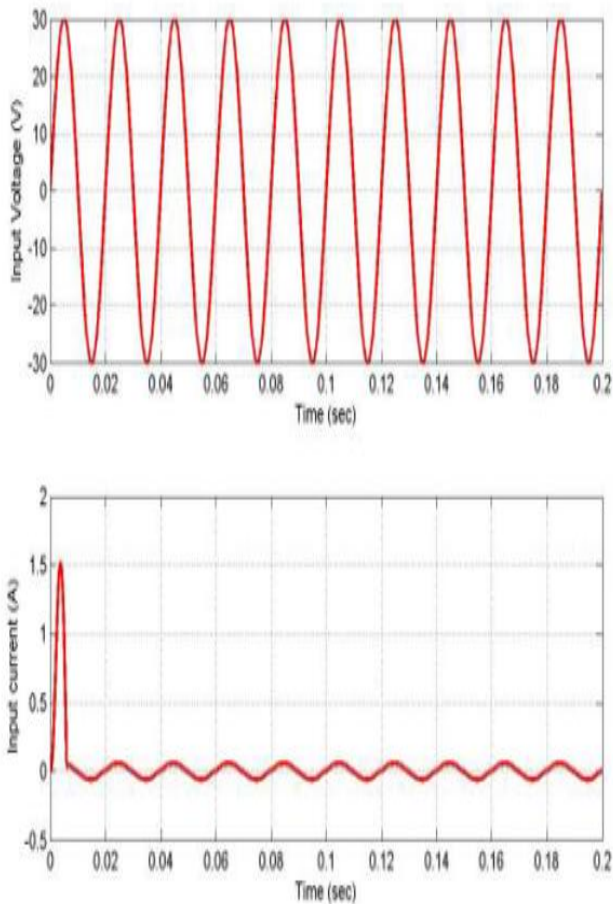


**VII. SIMULATION OF THE PROPOSED CONVERTER:**

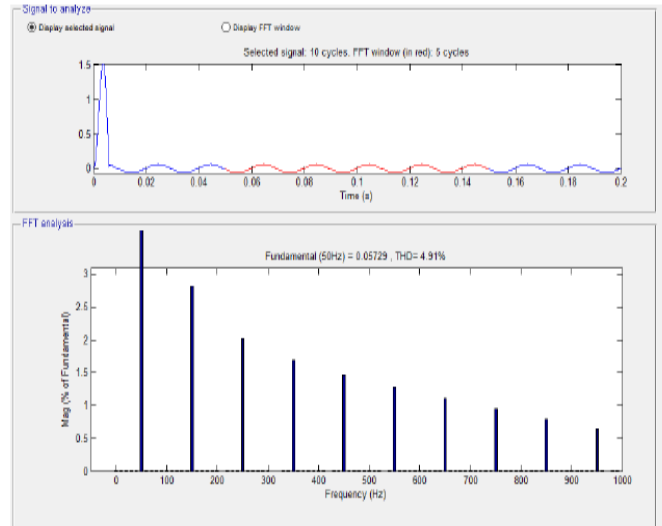


**Fig7. Circuit of proposed system**

Fig7 shows the circuit of the proposed system. The power semiconductor switch is triggered by means of pulse generator and the on and off of the switch is controlled by PWM pulse. By adjusting the duty cycle, the voltage level of the converter can be adjusted to meet the requirements. The aim of the simulation is to prove that the power factor of the system is improved.



**Fig8. Input current of proposed system**

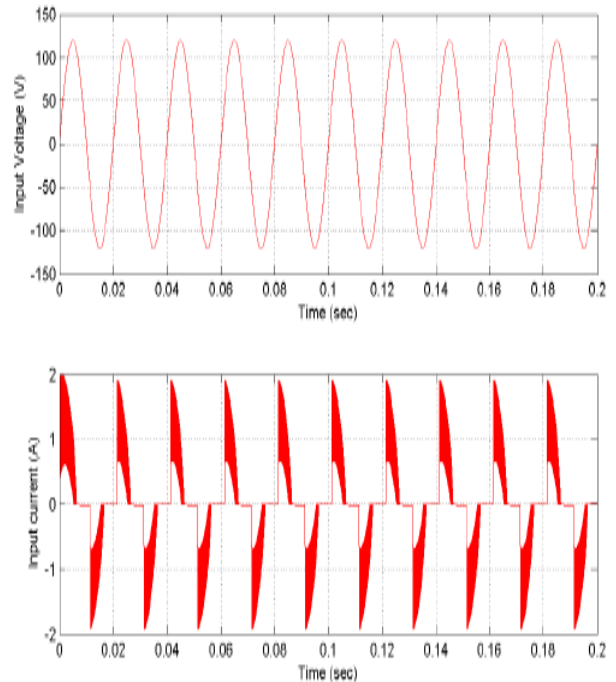


**Fig9. THD analysis of proposed circuit**

Fig8 depicts the input current of the proposed system and Fig9 depicts the THD analysis of the proposed circuit.

**VIII. IMPROVEMENT OF POWER FACTOR:**

The bipolar wave shape is converted to unipolar by means of rectifier circuit. It charges the capacitor and ensures that the voltage reaches the safe limit of the peak value. The surge limiting components are influenced by the circuit depicted in Fig9. The bridge rectifier causes an offset of leading phase angle (which should have been produced by large energy storage capacitance). Though there is zero phase displacement of capacitance current and input voltage, the present wave shape is not a pure sinusoidal as shown in Fig10.



**Fig10. Simulation outputs depicting input voltage and current waveform**

## Power Factor Improvement by Harmonic Reduction in Power System

The impure sinusoidal nature of current waveform raises critical problems for the AC voltage supply despite being in phase with the voltage.

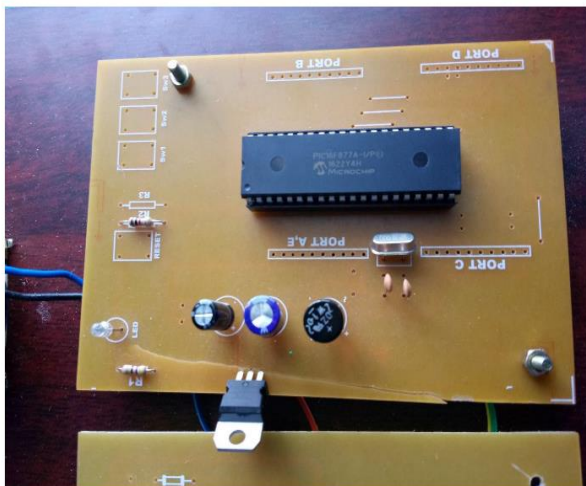
In order to make the input current wave more sinusoidal the power factor has to be improved. The above problem depicted in Fig10 is overcome by connecting the positive lift converter after the rectifier system. The result analysis comparing the performance and effectiveness of the existing system with the proposed system is shown in the Table 1 from which we can infer the level of improvement of power factor and elimination of harmonics in the system.

**Table 1: RESULT ANALYSIS**

PARAMETERS	EXISTING SYSTEM	PROPOSED SYSTEM
Total Harmonic Distortion (THD)	57.53%	4.91%
Input Voltage and Input Current	30V, 3.2A	30V, 1.5A
Output Voltage	28V	55V
Power factor	0.75	0.9
Overall Efficiency of the System	50% - 60%	75% - 85%

### IX. HARDWARE IMPLEMENTATION OF THE PROPOSED SYSTEM

It is inferred from the results that the power factor is improved. As the simulation results are successful, the hardware implementation of the proposed converter to improve power factor is fabricated and the prototype model includes the driver circuit and the rectifier circuit with positive output Luo converter and inductors. Finally they are assembled to produce a working model of the proposed topology.



**Fig11. PIC Controller Board**

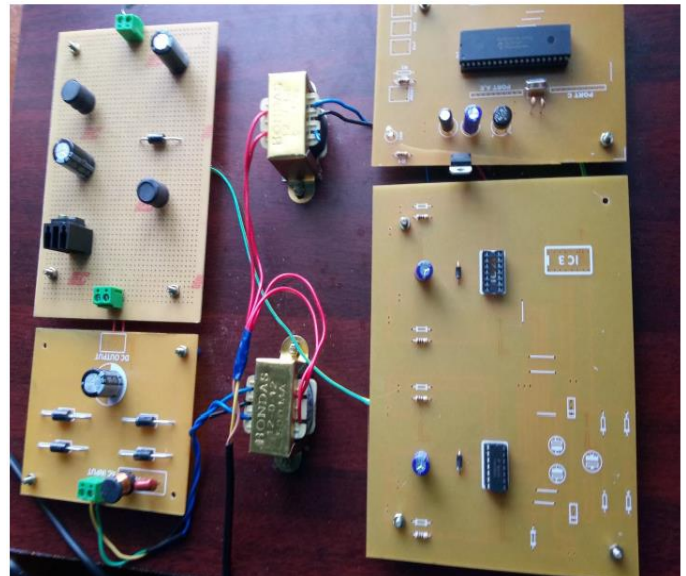
Fig11 shows the PIC controller board. The successful operation of the converter demands proper gating of the switches. PIC Microcontroller is used to generate the pulse of required frequency which is given as an input to the MOSFET switch. The generated pulse signal is given to the gate of the MOSFET. Depending upon the pulse the switch operation happens or interrupts. It is an open source

computer hardware and software. Generally the PIC controller boards are easy to program and is user friendly.



**Fig12. Driver circuit interfaced with PIC microcontroller**

Fig12 shows the driver circuit interfaced with the microcontroller. Fig13 shows the hardware implementation of the topology which reduces harmonics and improves the power factor of the system.



**Fig13. Hardware implementation of the topology**

The voltages across the switch are evaluated and are found to be admissible as per the simulation results. The voltages across the switch are measured with the help of the Multimeter. The input voltage of converter is 15V and across the switch is found to be 5V. The resultant voltage is found as 15V in the rectifier and 50V on interfacing with Luo converter.

**X. CONCLUSION AND FUTURE SCOPE**

The proposed converter topology has improved the power factor. It has rectifier circuit and positive lift Luo converter. The power factor can be improved by stacking the outputs. The energy dissipated from the storage components like the inductors and capacitors can be recycled by means of clamping diodes or clamping capacitors to the supply which provides an additive advantage to the system. The proposed converter improves the power factor by compensating the harmonics present in the system. The high gain converter improves the power factor by eliminating harmonics using active and passive filters. The rectifier circuit with Luo converter can be used for high voltage application. The converter input can be provided by using a solar cell. The voltage stress of the power semiconductor switches can also be reduced with the help of the proposed system. The system can also be extended to the grid oriented applications.

The overall outcome and result of the paper is understood with the help of the table 2 featuring the comparison of existing and proposed system.

**Table 2: Correlation of Existent and Flourishing System**

ASPECTS	EXISTENT SYSTEM	FLOURISHING SYSTEM
Performance	Excessive Harmonics Interferes the Performance of the System	Harmonics is Reduced or Eliminated
Wave shape	Not Purely Sinusoidal	Purely Sinusoidal
Power Factor Improvement	Poor	Good
Overall Efficiency of the System	Poor	Good

**REFERENCES:**

1. Tamotsu Ninomiya, Testsuro Tanaka and Koosuke Harada, "Analysis and Optimization of a Nondissipative LC Turn-Off Snubber", IEEE Transactions on Power Electronics, vol. 3, no. 2, pp. 147–156, Apr. 1988.
2. Wuhua Li, Jun Liu, Jiande Wu and Xiangning He, "Design and Analysis of Isolated ZVT Boost Converters for High-Efficiency and High-Step- Up Applications", IEEE Transactions on Power Electronics, vol. 22, no. 6, pp. 2363–2374, Nov. 2007.
3. Suman Dwari and Leila Parsa, "An Efficient High-Step-Up Interleaved DC–DC Converter with a Common Active Clamp", IEEE Transactions on Power Electronics, vol. 26, no. 1, pp. 66–78, Jan. 2011.
4. Hyun-Lark Do, "Improved ZVS DC–DC converter with a high voltage gain and a ripple-free input current", IEEE Transactions on Circuits Systems, vol. 59, no. 4, pp. 846–853, Apr. 2012.

**AUTHORS PROFILE**



**Sumitha.M** received the M.E. degree from SSN College of Engineering, Chennai in 2016 and B.E. degree from Prince Shri Venkateshwara Padmavathy Engineering College, Chennai in 2014 and currently working as Assistant Professor in the department of EEE in St. Joseph's College of Engineering, Chennai. She has published papers in international conferences and journals. She also possess the life membership card in Indian Society for Technical Education. Her research interests include Power electronics and drives, Machines, Wind energy conversion systems.



**Sujatha.R** received M.E degree from St.Joseph's College of Engineering, Chennai in 2015 and B.E degree from Sri Sairam Institute of Technology, Chennai in 2013 and currently working as Assistant Professor in the department of EEE in St.Joseph's College of Engineering, Chennai. She has published papers in International conferences and Journals. Her research interests includes Power Electronics and Drives, Solar energy conversion systems.



**Dr.Jamna.A** received Doctorate degree from Anna University, Chennai in 2017 and M.E degree from Jerusalem College of Engineering, Chennai in 2008 and B.E. degree from St.Joseph's College of Engineering, Chennai in 2003. She has 10 years of experience in teaching and one year of industrial experience. She has published papers in National and International conferences and Journals. Her research interests include Power Electronics, Matrix Converters, Electrical Drives and control, Power Quality improvements, Smart Grid, Power Conversion Techniques for Wind & PV systems.