

Implementation of Wireless Sensor Network Based Indoor Air Quality Monitoring System using GSM

P.Satyanarayana, R. Narmadha

Abstract: Humans spend more than 80% of their time indoors, therefore indoor air quality has a critical effect on the quality of health. It is necessary to keep our indoor environment clean and healthy to ensure good health. As the air quality has major influence on the health of people, it is necessary to keep our indoor environment clean and healthy. The main objective of this project is to provide real time information to assist the better living of the people. Because of the large variety of indoor pollutants, the air monitor should be designed multi-sensory and portable with acceptable sensitivity. The system will detect the level of the several gases like Carbon Dioxide (CO₂), Sulfur Dioxide (SO₂), Volatile Organic Compound (VOC) and also the presence of dust, temperature, and humidity. The system will alert the user if levels of these gases are exceeded through Wi-Fi module on their smart phones.

Key words: Arduino Uno, Wi-Fi module, Sensors,

I. INTRODUCTION

Nowadays every nation is suffering from air pollution. Many Health issues have been increasing at quicker rate particularly in metropolitan areas of embryonic countries where industrialization and budding quantity of vehicles leads to discharge of lot of sparkling pollutants. Destructive effects of toxic waste contain mild allergic reactions such as exasperation of the gorge, eyes and nose as well as several severe problems like, heart diseases, lung and aggravated asthma. In order to live clean and healthy indoor lifestyle, our indoor environment should be pollutant free. Indoor air gets polluted due to various pollutants like second hand smoke. It is tobacco smoke which affects people other than active smoker. Carbon monoxide is colorless, odorless gas that is a byproduct of incomplete combustion of fossil fuels and the other source is tobacco smoke. VOCs include a variety of chemicals, some of which may have adverse health effects which are emitted as gases from certain solids or liquids: paints and lacquers, paint strippers, cleaning supplies, pesticides, building materials and furnishings, office equipment such as copiers and printers, correction fluids, carbonless copy paper, graphics and craft materials. So these pollutants which are hazardous to our health need to be monitored and take appropriate measures are to be taken to control indoor air quality getting deteriorated.

Revised Manuscript Received on October 05, 2019

P.Satyanarayana, Assistant professor in ECE of V. R. Siddhartha engineering college.

R. Narmadha, Associate Professor in ECE of Sathyabama institute of science & Technology, Chennai.

Air Quality provides standards and objectives for key air pollutants, which are designed to protect human health and the environment. It can cause both short term and long term effects on health and many people are concerned about pollution in the air that they breathe. Air excellence index (AQI) is a measure used to assess the everyday air quality.

II. BLOCK DIAGRAM OF HARDWARE EXECUTION

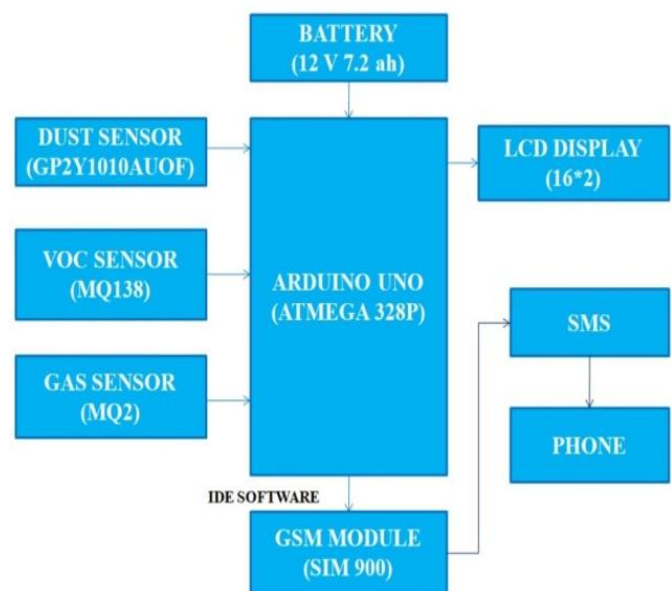

Fig 2.1 Block Diagram of Air Quality Monitoring System

III. HARDWARE REQUIREMENTS

The following are the hardware requirements for air quality monitoring system

- Battery
- Arduino Uno
- GSM Module
- LCD Display
- VOC Sensor
- Gas Sensor
- Dust Sensor

All the sensors (VOC Sensor, Gas Sensor, Dust Sensor), Battery (12 V, 7.2 A), GSM Module, LCD display (16*2) are connected to the ARDUINO UNO (ATMEGA 328P). Data flows between the modules are clearly indicated in fig 2.1.

IV. AIR QUALITY MONITORING SYSTEM USING GSM

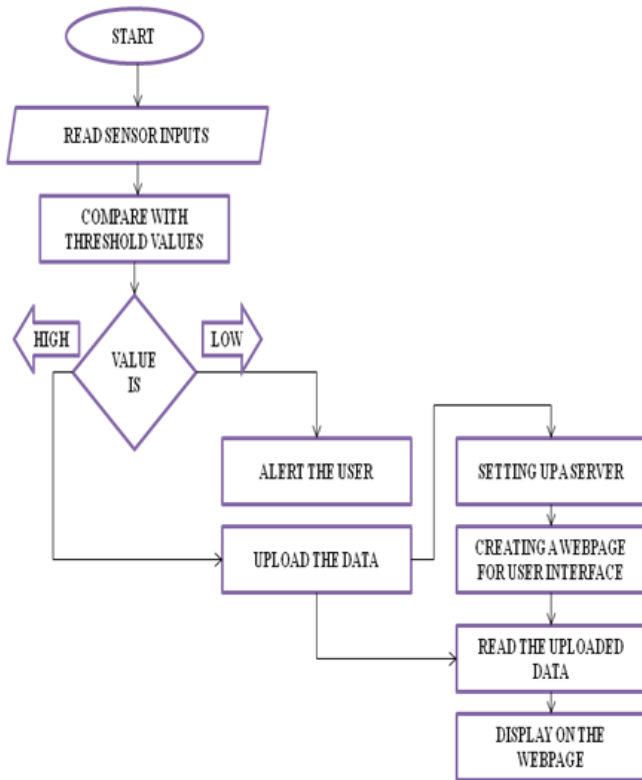

Fig 4.1 Flow chart of Air Quality Monitoring System using GSM

- Step 1: Switch ON the kit and read the sensors inputs
- Step 2: Compare the sensors value with the threshold values
- Step 3: If the value is greater than the threshold value, alert the user by sending a message to the registered mobile number
- Step 4: Upload the data of the sensors output
- Step 5: Set up a server and create a webpage for user interface
- Step 6: Read for the uploaded data
- Step 7: Display the outputs on the webpage

4.1.1 VOC Sensor using GSM:

- Step 1: Switch ON the kit then the VOC sensor is enabled.
- Step 2: If the value from the sensor is above 500ppm a message will be displayed on the LCD screen.
- Step 3: Then an alert message is sent to the user's phone and the precaution is taken.
- Step 4: After certain delay the sensor again starts monitoring.
- Step 5: If the value is not above 500ppm the sensor repeats its operation.

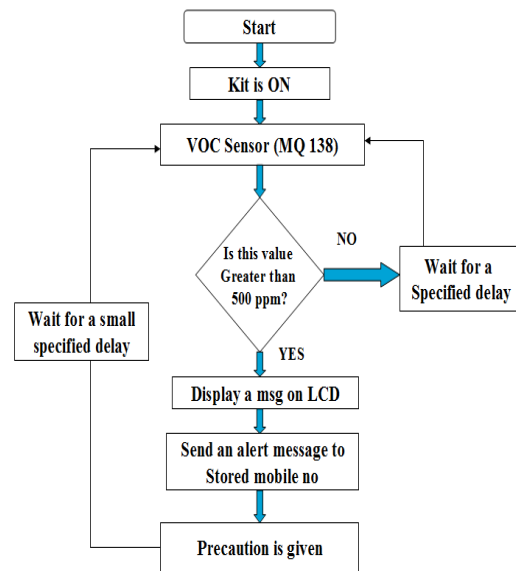

Fig 4.1.1 Flow chart of VOC Sensor using GSM

4.1.2 GAS Sensor using GSM:

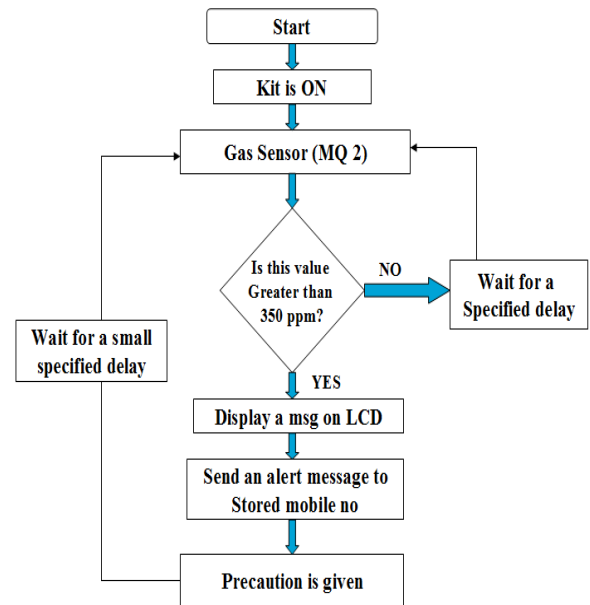

Fig 4.1.2 Flow chart of GAS Sensor using GSM

- Step 1: Switch ON the kit then the GAS sensor is enabled.
- Step 2: If the value from the sensor is above 350ppm, message will be displayed on the LCD screen.
- Step 3: Then an alert message is sent to the user's phone and the precaution is taken.
- Step 4: After certain delay the sensor again starts monitoring.
- Step 5: If the value is not above 350ppm the sensor repeats its operation.

4.1.3 DUST Sensor using GSM:

- Step 1: Switch ON the kit then the Dust sensor is enabled.

Step 2: If the value from the sensor is above 10 pm a message is displayed on the LCD screen.
Step 3: Then an alert message is sent to the user's phone and the precaution is taken.
Step 4: After certain delay the sensor again starts monitoring.
Step 5: If the value is not above 10 pm the sensor repeats its operation.

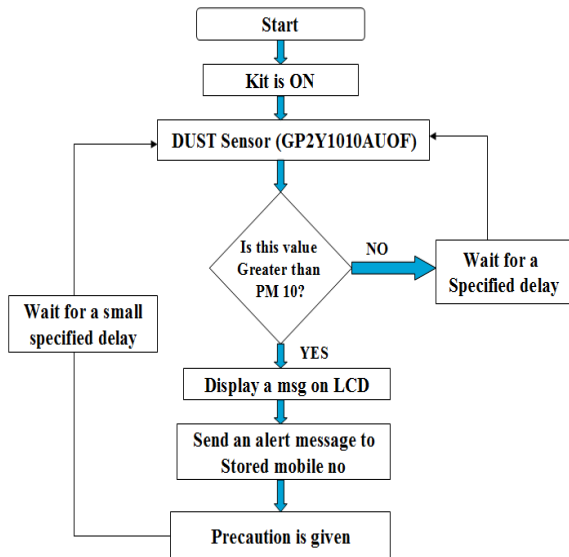

Fig 4.1.3 Flow chart of DUST Sensor using GSM

4.1.4 Temp and Humidity Sensor using GSM:

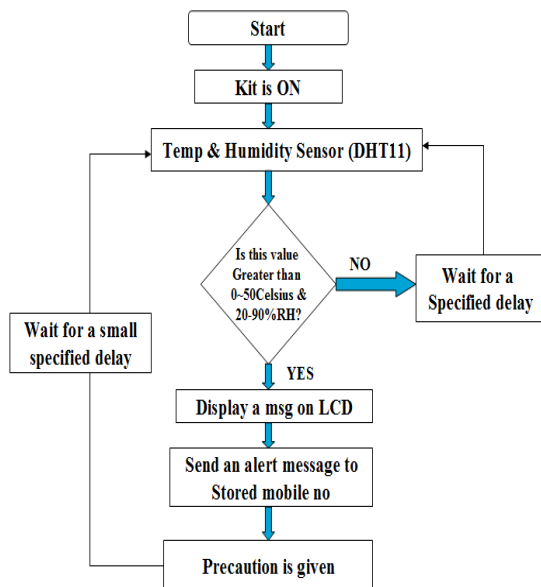

Fig 4.1.4 Flow chart of Temp and Humidity Sensor using GSM

Step 1: Switch on the kit then the Temperature & Humidity sensor is enabled.
Step 2: If the value from the sensor is above 0-50 degree Celsius & 20-90% RH, message is displayed on the LCD screen.
Step 3: Then an alert message is sent to the user's phone and the precaution is taken.

Step 4: After certain delay the sensor again starts monitoring.

Step 5: If the value is not above 0-50 degree Celsius & 20-90% RH the sensor repeats its operation.

V. RESULTS

5.1 Interfacing of Hardware Modules using GSM:

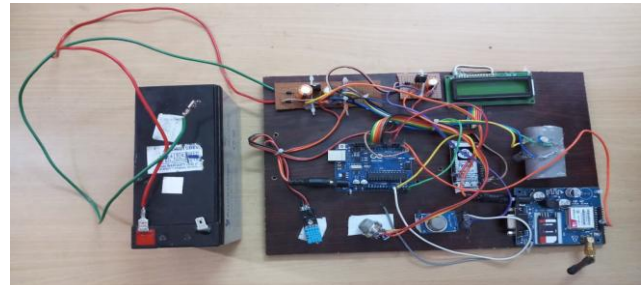

Fig 5.1 Interfacing of sensors with Arduino Uno

The above fig 5.1 shows the schematic view of “Real Time Indoor Air Quality Monitoring System Using Arduino Uno” which measures the quality of air using sensors (VOC, Gas, Dust, Temperature and Humidity) connected to Arduino Uno. When power supply is given through battery then the kit is on. The code required to detect the output is written in Arduino Uno IDE software. Due to the communication link between the Arduino Uno and IDE software the code is dumped into the Arduino Uno. When the power supply reaches the Arduino Uno and sensors then the air quality is detected at different places.



Fig 5.2 Representation of Hardware modules when the power is ON

5.2 Various Outputs of Sensors using GSM:

The values that are detected from different sensors are displayed on Liquid Crystal Display (LCD). VOC and Gas sensors measure the quality of



Fig 5.2.1 Standard levels of different gases in air

Implementation of Wireless Sensor Network Based Indoor Air Quality Monitoring System using GSM

air in ppm (parts per million), Dust sensor measures the quality of air in percentage. GSM module is necessary to send alert messages to phone whenever the quality of air exceeds the required standards. The above values that are displayed on LCD show the normal standards of air quality.



Fig 5.2.2 Exceeded level of VOC gases in air

The standard level of a Volatile Organic Compound (VOC) sensor is 2500ppm. It detects the organic compounds like alcohol, hydrogen, toluene etc. The value of VOC sensor in the LCD display is 3430ppm. Since the level of VOC in the air exceeds the standards it sends an alert message to phone through GSM module.



Fig 5.2.3 Alert message send to phone when VOC gas exceeds in air

The alert message is sent through GSM module to the phone "The VOC sensor value exceeded limits: 3430 please alert!"



Fig 5.2.4 Exceeded level of MQ 2 sensor gases in air

The standard level of a Gas sensor is 2500ppm. It detects the gases like Methane, Butane, LPG, and Smoke. The value of Gas sensor in the LCD display is 3411ppm. Since the level of gases in the air exceeds the standards it sends an alert message to phone through GSM module.

The alert message "The Gas sensor value Exceeded limits: 3411, please alert" is sent through GSM module to phone.

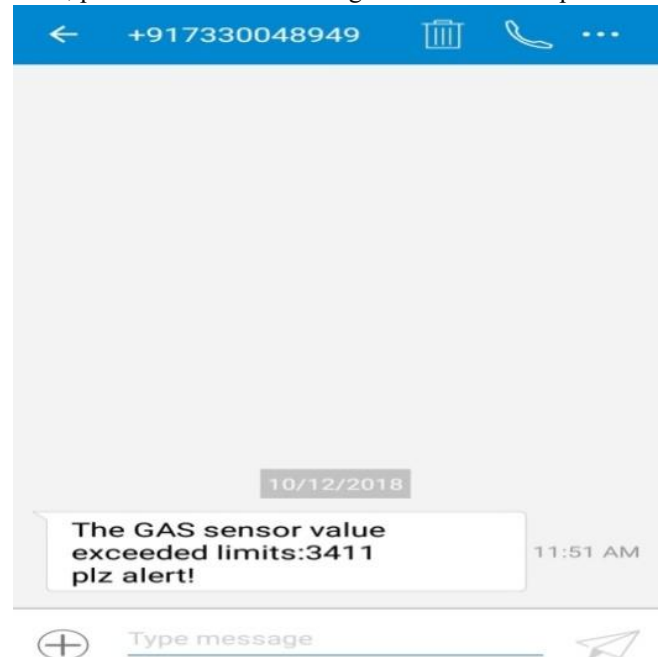
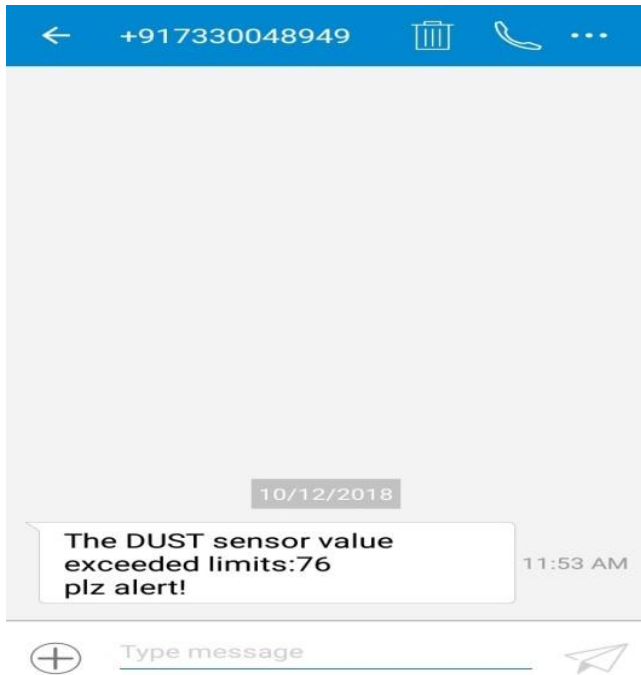

Fig 5.2.5 Alert message send to phone when gases of MQ 2 exceeds in air

The standard level of a Dust sensor is 10%. It detects the dust particles present in the air. Larger the size of the particle, greater the percentage. The value of Dust sensor in the LCD display is 76%. Since the level of dust particles in air exceeds the standards, it sends an alert message to phone through GSM module. The alert message is sent through GSM module to phone that "The Dust sensor value Exceeded limits: 76 please alert!"



Fig 5.2.6 Exceeded level of dust and smoke in air



**Fig 5.2.7 Alert message send to phone when dust and smoke exceeds in air
Comparison of Theoretical and Practical values using GSM:**

Air Quality Monitoring System Using GSM		
SENSOR	THEORITICAL VALUE	PRACTICAL VALUE
VOC	2500 PPM	961 PPM
GAS	2500 PPM	1464 PPM
DUST	100%	16%

VI. CONCLUSION

To live a healthier life we have proposed a system that is “Real Time Indoor Air Quality Monitoring System Using Arduino Uno” to sense the levels of harmful gases present in the air by using sensors like VOC, Gas, Dust, Temperature and Humidity. Experimental results have shown that the system can detect the presence of organic compounds, dust particles and gases at an acceptable sensitivity.

When the standard levels are exceeded, alerts and notifications will be sent to user phone through GSM module to take preventive measures against indoor air conditions surrounding them. Since the sensors can detect only up to 100 meters it cannot be used in wide area applications. So in future the project can be implemented using wide range sensors to measure the quality of air.

REFERENCES

1. Ching-Biau Tzeng, et al., “Design and Implement a Cost Effective and Ubiquitous Indoor Air Quality Monitoring System Based on ZigBee Wireless Sensor Network” Innovations in Bio-inspired Computing and Applications (IBICA), 2011 2nd International Conference on 16-18 Dec. 2011, pp. 245 – 248.

2. Bhattacharya S., et al., "Indoor air quality monitoring using wireless sensor network" Sensing Technology (ICST), 2012 Sixth International Conference on , vol., no., pp.422, 427, 18-21 Dec 2012.
3. S. N. Kamaruzzaman, et al., “The Effect of Indoor Air Quality (IAQ) Towards Occupants’ Psychological Performance in Office Buildings” Journal of Design and the Built Environment, vol. 4, no. 2001, pp. 49–61, 2011.
4. P. Spachos, Liang Song, D. Hatzinakos, "Prototypes of opportunistic wireless sensor networks supporting indoor air quality monitoring", *Consumer Communications and Networking Conference (CCNC) 2013 IEEE*, pp. 851-852, Jan 2013.
5. R du Plessis ; A Kumar ; GP Hancke ; BJ Silva , “A wireless system for indoor air quality monitoring” IECON 2016 - 42nd Annual Conference of the IEEE Industrial Electronics Society 2016.
6. J.-J. Kim, S. K. Jung, J. T. Kim, "Wireless monitoring of indoor air quality by a sensor network", *Indoor and Built Environment*, vol. 19, pp. 145-150, 2010.
7. Kyeong T. Min, Andrzej Forsys, Thomas Schmid, “Demonstration Abstract: Air Feed - Indoor Real Time Interactive Air Quality Monitoring System” – 2014.
8. Jeffrey P. Smith; Xinrong Li, “Air Sniffer: A Smartphone-Based Sensor System for Body Area Climate and Air Quality Monitoring” – 2016.

AUTHORS PROFILE



P. Satyanarayana presently working as an Assistant professor in ECE of V. R. Siddhartha engineering college. He is presently doing his part-time Ph. D in Sathyabama institute of science & Technology, Chennai in the area of wireless networks. He received his M. Tech degree from Acharya Nagarjuna University in Communications and Signal Processing. He received his B. Tech degree from JNTUH in ECE. His research interest lie in the area of Network Security in IoT, Energy efficiency and improving network lifetime of wireless sensor network



R. Narmadha presently working as an Associate Professor in ECE of Sathyabama institute of science & Technology, Chennai. Her research interest lies in the area of Wireless networks and Network security.