

Simulation and Analysis of DFIG System with Wind Turbine Implementing Fuzzy Logic Control

Karanam Deepak, Talari Aparna, A. Suresh Kumar, P Siva Deepthi, Y Hazarathaiah

Abstract: A doubly-fed induction generator (DFIG) applied to wind power generation driven by wind turbine is under study for low voltage ride-through application during system unbalance. Use of DFIG in wind turbine is widely spreading due to its control over DC voltage and active and reactive power. Conventional dq axis current control using voltage source converters for both the grid side and the rotor side of the DFIG are analyzed and simulated. An improved control and operation of DFIG system under unbalanced grid voltage conditions by coordinating the control of both the rotor side converter (RSC) and the grid side converter (GSC) is done in this thesis. Simulation and analysis of DFIG system with wind turbine using Fuzzy logic controller for RSC and GSC under unbalanced condition is presented in the positive synchronous reference frame. The common DC-link voltage is controlled by grid side converter and control of DFIG's stator output active and reactive power is controlled by rotor side converter. The steady-state operation of the DFIG and its dynamic response to voltage sag resulting from a remote fault on the 120-kV system is shown in this thesis using controllers. Modeling of DFIG system under Fuzzy logic controller to control voltage and active-reactive powers is done using MATLAB/SIMULINK.

Keywords: doubly-fed induction generator (DFIG), rotor side converter (RSC), grid side converter (GSC).

I. INTRODUCTION

Wind imperativeness is one of the maximum open and exploitable types of value-effective power source. Wind blows from a location of better air weight to one of the

Revised Manuscript Received on October 20, 2019.

* Correspondence Author

Karanam Deepak, Assistant Professor Department of Electrical & Electronics Engineering, G. Pullaiah College of Engineering and Technology, Near Venkayapalle, Pasupula Village, Nandikotkur Rd, Kurnool, Andhra Pradesh 518002

Talari Aparna, Assistant Professor Department of Electrical & Electronics Engineering, G. Pullaiah College of Engineering and Technology, Near Venkayapalle, Pasupula Village, Nandikotkur Rd, Kurnool, Andhra Pradesh 518002

A Suresh Kumar, Assistant Professor Department of Electrical & Electronics Engineering, G. Pullaiah College of Engineering and Technology, Near Venkayapalle, Pasupula Village, Nandikotkur Rd, Kurnool, Andhra Pradesh 518002

P Siva Deepthi, Assistant Professor Department of Electrical & Electronics Engineering, G. Pullaiah College of Engineering and Technology, Near Venkayapalle, Pasupula Village, Nandikotkur Rd, Kurnool, Andhra Pradesh 518002

Y Hazarathaiah, Assistant Professor Department of Electrical & Electronics Engineering, G. Pullaiah College of Engineering and Technology, Near Venkayapalle, Pasupula Village, Nandikotkur Rd, Kurnool, Andhra Pradesh 518002

decrease herbal weight. The qualification in weight is performed by using:

(A) How international's surface isn't reliably warmed via the sun and

(B) The arena's insurgency.

The worldwide electric powered essentialness is growing and there may be a reliable growing of the passion on electricity age, transmission, scattering and use. The most exquisite extractable essentialness from the zero-100m layer of air has been assessed to be the solicitation for 1012 KWh/annum, that is of a similar solicitation as hydroelectric capacity. Because of the fact most dependable recorded facts, wind power has been used to move ships, weigh down grain and siphon water. This is the affirmation that breeze essentialness become used to stress barges along the Nile River as mid 5000 B.C. Interior multiple masses of years earlier than Christ; direct windmills were used in china to siphon water. In the u.S., endless windmills have been raised as the American West turned into made throughout the late 19th century. Maximum of them had been used to siphon water for houses and ranches. By way of 1900, minimum electric powered powered breeze structures have been made to create motion, yet a huge section of those gadgets crash and burn into push aside as realistic system power modified into prolonged to not unusual domains throughout the nineteen Thirties. Via 1910, wind turbine mills were conveying power in numerous ecu nations. Wind generators are to be had in an expansion of duration, and thusly manipulate exams. The greatest machine, as an example, the best understood Hawaii, has propellers that range the extra than the period of a soccer challenge and stands 20 constructing memories immoderate, and conveys sufficient potential to control 1400 houses. A little home-sized breeze machine has rotors some location inside the scope of 8 and 25 ft in separation crosswise over and stands upwards of 30 feet and may deliver the electricity desires of an all-electric powered domestic or privately owned organisation. All electric powered powered-making wind turbines, paying little appreciate to what period, are contained or three essential portions: (the part that honestly turns inside the breeze), the electric generator, a speed manage form, and an apex. A few wind device have guard shutdown shape in order that if part of the device crashes and burns, the shutdown device turn the pushes out of the breeze or places brakes.

On this paper phase-I includes the important bit of wind turbine and the upsides of wind turbine, facts of global provided devices of wind energy and quick advent of doubly supported acknowledgment generator. Fragment 2 affords related artwork of doubly strengthened acknowledgment generator shape with wind turbine in balanced state of affairs. Sector 3 of this paper fuses the showing of doubly supported enrollment generator (DFIG) shape with an uneven state of affairs with wind turbine and showing of its rotor facet converter (RSC) and system element converter (GSC), furthermore the sorted out manage of RSC and GSC is explained in this element. Territory 5 demonstrates the unmistakable manage systems as PI-R, Fuzzy approach of reasoning controller and Pitch thing manage for DFIG shape with wind turbine. Location 6, the enjoyment and results are joined into which the similar examination displaying the evaluation of PI-R and Fuzzy justification controller used with DFIG system with wind turbine.

II. LITERATURE SURVEY

A massive amount of studies paintings has been completed inside the district of wind manipulate propels in electricity systems which incited the development of different strategies and techniques. A quick composition evaluate of these methods of questioning and strategies is offered under.

J. Hu et al. [1] confirmed every other control philosophy for a doubly fed induction generator (DFIG) underneath inconsistent framework voltage situations. Made control out of the rotor side converters at some stage in voltage unbalance is proposed. To offer specific manage of the high-quality-and negative synchronous streams of the GSC and RSC, a gift control plan regarding a relative vital (PI) controller and a changeable (R) compensator is shown. The PI not withstanding R current controller is accomplished inside the high quality synchronous reference framework diagram without the want to interrupt down the tremendous and poor-amassing fragments.

Falsehood Xu and Yi Wang [2] proposed a DFIG shape version in the powerful and positive synchronous reference housings is shown. Assortments of stator dynamic and responsive powers and generator torque are completely portrayed interior seeing negative progression voltage and contemporary. Optionally available DFIG control facilities at some stage in framework unbalance are perceived. A rotor modern-day manipulate method issue to terrific and terrible (dq) reference edges is used to present correct control of the rotor positive synchronous frame.

F. Mei and B. Mate [5] analyzed the measured evaluation of a bypass phase related doubly fed induction generator (DFIG). The trade specially houses for one of a kind of implement parameters, operating centers, and section qualities are prepared and regarded. The consequences offer a appreciation of the DFIG trademark additives, which can in like manner be valuable for control plan and version legitimization.

III. MODELING OF DFIG SYSTEM WITH AN UNBALANCED GRID

A. General

Wind turbines use a doubly-fed induction generator (DFIG) containing wound rotor induction generator and an

AC/DC/AC IGBT-primarily based PWM converter. The stator winding is related actually connected to the 60 Hz even as the rotor is empowered at variable frequency through the AC/DC/AC converter. The DFIG technology is extracting maximum energy from the wind for low wind speeds with the aid of propelling the turbine speed, even as limiting mechanical loads at the turbine during unbalance. The perfect turbine speed making maximum outstanding mechanical essentialness for a given wind velocity is with appreciate to the wind velocity. Each other discriminating position of the DFIG development is the restriction with recognize to manipulate control converters to create or take in responsive strength, along those lines abstaining from the prerequisite for presenting capacitor banks as because of squirrel-cage induction generator.

In favor of a doubly-fed induction generator wind generation system implement, the DFIG's stator yield dynamic as well as responsive electricity is prescribed via RSC, but the GSC control the regular dc-interface voltage. Detailed models of both RSC and GSC are described in this paper.

B. Numerical model of RSC with GSC

The phase figure shown in Fig.1 show the spatial correlation among the stationary frame $\alpha_s\beta_s$ border, rotor $\alpha_r\beta_r$ frame revolving by the pointed rapidity of ω_r , as well as dq^+ and dq^- frame revolving at the pointed speeds of ω_s as well as $-\omega_s$ [2]

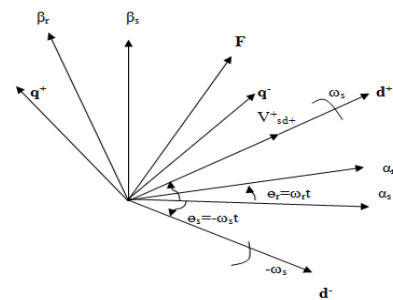

Fig.1 Relationship between the ($\alpha_s \beta_s$), ($\alpha_r \beta_r$) and the dq^+ and dq^- reference frames.

In the Fig.1, the conversion involving $\alpha\beta$, dq^+ , as well as dq^- position frame in favor of vector F , are specified by [1],[3],[23].

$$F_{dq^+}^+ = F_{\alpha_s\beta_s} e^{-j\omega_s t} \quad F_{dq^-}^- = F_{\alpha_s\beta_s} e^{j\omega_s t} \quad (1)$$

$$F_{dq^+}^- = F_{dq^-}^+ e^{-j2\omega_s t} \quad F_{dq^-}^- = F_{dq^+}^+ e^{j2\omega_s t} \quad (2)$$

$$F_{dq^+}^+ = F_{\alpha_r\beta_r} e^{-j\omega_{slip}^+ t} \quad F_{dq^-}^- = F_{\alpha_r\beta_r} e^{j\omega_{slip}^- t} \quad (3)$$

Where F represent the voltage, current and flux. $\omega_{slip^+} = \omega_s - \omega_r$ and $\omega_{slip^-} = -\omega_s - \omega_r$.

During voltage imbalance, the voltage, current, and flux all positive- and negative-sequence components. Based on (1)–(3) and shown in Fig. 1, F can be expressed in terms of positive- and negative-sequence components with respective positive and negative rotating synchronous frames as,



$$F_{dq}^+ = F_{dq}^+ + F_{dq-}^+ = F_{dq}^+ + F_{dq-}^- e^{-j2\omega_s t} \quad (4)$$

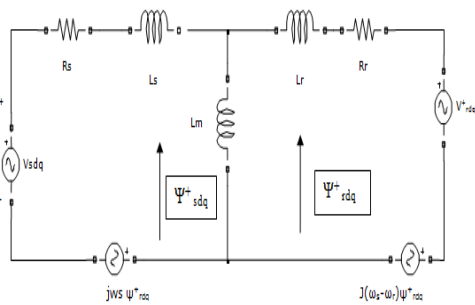

Fig.2 DFIG corresponding path during the positive synchronous reference border revolving at ω_s

C. RSC (DFIG) Model

Fig.2 shows DFIG equivalent circuit in the positive synchronous reference frame.

The stator output active and reactive powers under unbalanced network situation are expressed as [2], [3], and [10]

$$P_s = P_{s0} + P_{ssin2} \sin 2\omega_s t + P_{scos2} \cos 2\omega_s t \quad (5)$$

$$Q_s = Q_{s0} + Q_{ssin2} \sin 2\omega_s t + Q_{scos2} \cos 2\omega_s t \quad (6)$$

Where

$$\begin{bmatrix} P_{s0} \\ Q_{s0} \\ P_{ssin2} \\ P_{scos2} \\ Q_{ssin2} \\ Q_{scos2} \end{bmatrix} = \frac{3}{2} \omega_s L_s \begin{bmatrix} 0 & 0 & 0 & 0 \\ V_{sq+}^+ & -V_{sd+}^+ & -V_{sq-}^- & V_{sd-}^- \\ -V_{sq-}^- & -V_{sd-}^- & -V_{sq+}^+ & -V_{sd+}^+ \\ -V_{sd-}^- & V_{sq-}^- & V_{sd+}^+ & -V_{sq+}^+ \\ 0 & 0 & 0 & 0 \\ 0 & 0 & 0 & 0 \end{bmatrix} X \begin{bmatrix} V_{sq+}^+ \\ V_{sd+}^+ \\ V_{sq-}^- \\ V_{sd-}^- \end{bmatrix}$$

$$+ \frac{3L_m}{2L_s} \begin{bmatrix} V_{sd+}^+ & V_{sq+}^+ & V_{sd-}^- & V_{sq-}^- \\ V_{sq+}^+ & -V_{sd+}^+ & V_{sq-}^- & -V_{sd-}^- \\ V_{sq-}^- & -V_{sd-}^- & -V_{sq+}^+ & V_{sd+}^+ \\ V_{sd-}^- & V_{sq-}^- & V_{sd+}^+ & V_{sq+}^+ \\ -V_{sd-}^- & -V_{sq-}^- & V_{sd+}^+ & V_{sq+}^+ \\ V_{sq-}^- & -V_{sd-}^- & V_{sq+}^+ & -V_{sd+}^+ \end{bmatrix} X \begin{bmatrix} I_{rd+}^+ \\ I_{rq+}^+ \\ I_{rd-}^- \\ I_{rq-}^- \end{bmatrix} \quad (7)$$

correspondingly the electromagnetic power is.

$$P_e = -\frac{3}{2} \text{Re} [j\omega_s \psi_{sdq}^+ I_{sdq}^+ + j\omega_{slip} \psi_{rdq}^+ I_{rdq}^+] = P_{e0} + P_{esin2} + P_{ecos2} \quad (8)$$

Where

$$\begin{bmatrix} P_{e0} \\ P_{esin2} \\ P_{ecos2} \end{bmatrix} = \frac{3L_m \omega_t}{2L_s \omega_s} \begin{bmatrix} V_{sd+}^+ & V_{sd+}^+ & -V_{sd-}^- & V_{sq-}^- \\ -V_{sq-}^- & V_{sd-}^- & -V_{sq+}^+ & V_{sd+}^+ \\ -V_{sd-}^- & -V_{sq-}^- & V_{sd+}^+ & V_{sq+}^+ \\ -V_{sq-}^- & -V_{sd-}^- & V_{sq+}^+ & -V_{sd+}^+ \end{bmatrix} \begin{bmatrix} I_{rd+}^+ \\ I_{rq+}^+ \\ I_{rd-}^- \\ I_{rq-}^- \end{bmatrix} \quad (9)$$

Neglect the stator as well as rotor windings' copper losses, the active power input to the rotor is

$$P_r = P_s - P_e \quad (10)$$

D. GSC (DFIG) Model

The grid side converter can be decomposed into positive-sequence components. According to reference [1], [2] and [10], the stator active and reactive powers from the GSC to the ac network can be expressed by

$$P_g = P_{g0} + P_{gcos2} \cos 2\omega_s t + P_{gsin2} \sin 2\omega_s t \quad (11)$$

$$Q_g = Q_{g0} + Q_{gcos2} \cos 2\omega_s t + Q_{gsin2} \sin 2\omega_s t \quad (12)$$

Based on above power equations can be simplified calculation by taking into account into account $V_{sd+}^+ = 0$.

The ordinary dc-link voltage preserve be resulting in view of the power fluctuation diagonally the combination inductor L_g of the GSC as

$$\begin{bmatrix} P_{X0} \\ P_{Xsin2} \\ P_{Xcos2} \end{bmatrix} = 3\omega_s L_g \begin{bmatrix} 0 & 0 \\ I_{gd+}^+ & I_{gq+}^+ \\ I_{gq+}^+ & -I_{gd+}^+ \end{bmatrix} \begin{bmatrix} I_{dq-}^- \\ I_{gq-}^- \end{bmatrix} \quad (13)$$

$$T_g = \frac{P_g}{\omega_r} = \frac{P_{e0} + P_{esin2} + P_{ecos2}}{\omega_r} \quad (14)$$

E. Coordinated control of RSC and GSC

The 4 rotor current components and 4 network current components that can be controlled to improve system operated. under unbalanced grid voltage conditions are

are $I_{rd+}^+, I_{rq+}^+, I_{rd-}^-, I_{rq-}^-$ and $I_{gd+}^+, I_{gq+}^+, I_{gd-}^-, I_{gq-}^-$ respectively.

for the RSC, apart from the normal

stator yield dynamic and receptive forces P_{s0} and Q_{s0} , two power/torque swaying terms can be controlled. Likewise the GSC's normal dynamic P_{g0} and receptive Q_{g0} control, in addition to its two wavering force terms, can be controlled.

$$P_{total} = P_s + P_g \quad (15)$$

Based on (6),(7),(9) and (16), the total active power is

$$P_{total} = P_s + P_g = (P_{s0} + P_{g0}) + (P_{ssin2} + P_{gsin2}) \sin 2\omega_s t + (P_{scos2} + P_{gcos2}) \cos 2\omega_s t \quad (16)$$

$$P_{ssin2} + P_{gsin2} = 0$$

$$P_{scos2} + P_{gcos2} = 0 \quad (17)$$

For the RSC, the required positive- and negative -sequence rotor currents can be calculated by setting



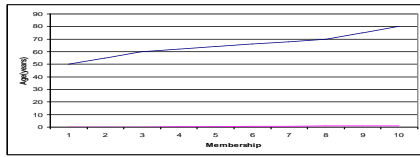

Fig.5 model of a relationship function in support of fuzzy logic sets.

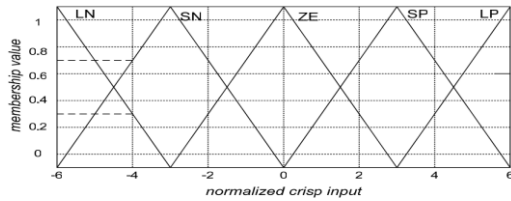

Fig.6. model relationship function worn through a fuzzifier.

i) Rule base

The rule base maps the fuzzy sets for the inputs to the fuzzy sets for the output and constitutes the core of a fuzzy controller. Table 10 shows a sample rule base. SN, LN, LP are notations for fuzzy sets named Small Negative, Large Negative, Large Positive respectively. Let A denote the fuzzy variable input 1, B denote input 2, O denote the output, a denote the value of input 1, b denote the value of input 2 and o denote the value of the output.

Table 1 example ruling stand for a FLC

		Input 2				
		LN	LN	LN	LN	LN
Input 1	LN	LN	LN	LN	SN	ZE
	SN	LN	SN	SN	ZE	SP
	ZE	LN	SN	ZE	SP	LP
	SP	SN	ZE	SP	SP	LP
	LP	ZE	SP	LP	LP	LP

Where μ denotes the membership function. The membership function of the yield in favor of the position SN is acquire because a consequence of valuation of the over imperative as well as is denote by μ_0^{SN-k} . If the highest occupation is use meant for the OR function, we get:

$$\mu_o^{SN}(o) = \max(\mu_0^{SN-i}) \tag{32}$$

ii) Defuzzifier

The yield of the usual base is a fuzzy variable which is modified crisp value by the defuzzifie. several defuzzification techniques had been proposed, of which the point of interest of quarter or centroid defuzzification is usually normal. utilizing this approach, the crisp output is given by using:

$$O = \frac{\sum_{i=1}^P \mu_i A_i c_i}{\sum_{i=1}^P \mu_i A_i} \tag{33}$$

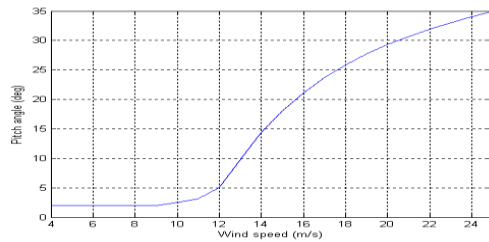
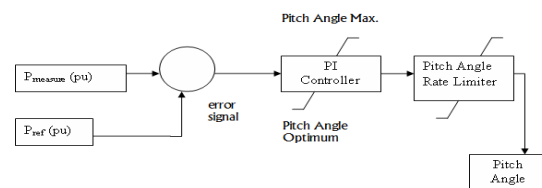

Fig. 4.6: Relationship between Pitch Angle and Wind Speed

The pitch angle controller employs a PI (proportional integral) controller as shown below.



In Fig.7. Exactly when the wind turbine control Pmeasured is lower than the assessed electricity Pref of wind turbine, the error signal is positive and pitch angle changes a value at fixed rate, reducing total area of the blade, to reduce the output power. All controller inputs are p.u.

V. SIMULATION RESULT ANALYSIS

A) Simulated model

DFIG primarily based absolutely wind power generation system have been conducted the usage of Matlab/Simulink. Discrete signals have been used with an sampling frequency 10kHz and generation time journey of 5 μ s. The DFIG is assessed at 1.5 MW, with parameters recorded in fig 8.

Table 2 Parameters of the Simulated DFIG

Rated power	1.5 MW
Stator voltage	690 V
Stator rotor turns ratio	0.38
Rs	0.00706 pu
Rr	0.005 pu
Lm	2.9 pu
L σ s	0.171pu
L σ r	0.156 pu
Lumped inertia constant	5.04 s

A single degree load on the important side of the coupling transformer is used to supply on the voltage unbalance. The apparent dc-interface voltage is 1200 V and the buying and



selling repeat for every the GSC and RSC is 5 kHz.

Five.2 consequences from PI-R current-day controller

In Fig. 9, while the unbalance came about at 0.3 s, ordinary vector manipulate realizes critical torque and strength moves with little manage of the terrible collecting streams. Precisely while the R controller for the RSC is enabled at 0.5 s, the rotor horrible-development streams are rapid coordinated and in this way, electromagnetic torque and the stator responsive power movements lower expeditiously ,as showed up in Fig.10 and Fig.11. In any case, as a result of the bad manipulate of the GSC's poor progression streams, as confirmed up in Fig. 12 and Fig. 13, the hard and fast yield dynamic electricity and the dc-interface voltage both include full-size a hundred-Hz moves.

Table 3 Control Parameters for the GSC and RSC

	K_i P	K_{ii}	K_{iR}	ω_c (rad/sec)
GSC	2.5	350	500	1.5
RSC	2.5	25	500	2.5

This is shown clearly in Fig. 14 when the R controller for the GSC is enabled at 0.7 s, the GSC's negative-sequence currents are quickly regulated. Consequently, the stator output active power oscillation is compensated by the GSC. This leads to the complete elimination of the generated total active power, as shown in Fig.14.

Simulated Results:

The characteristics of DFIG fed wind turbine with control method of rotor current (I_{rabc}), stator current (I_{sabc}), dc link voltage(Vdc), torque (T_e), active power (P MW), reactive power (Q MVAR) using PI-R controller are simulated.

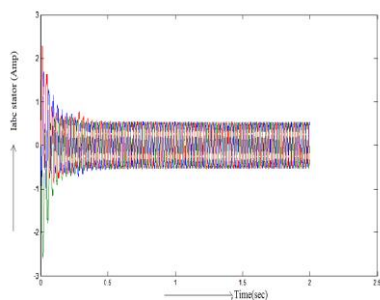

Fig.8. Simulation results with control method of stator current using PI-R controller

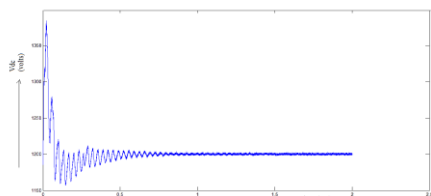

Fig.9.Simulation results with control method of V_{dc} using PI-R controller

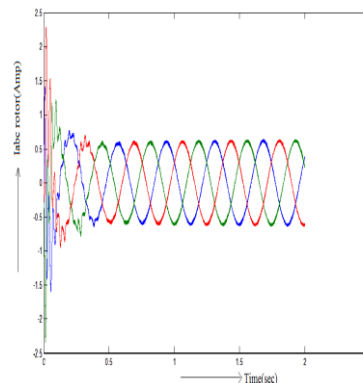

Fig.10 Simulation results with control method of rotor current using PI-R controller.

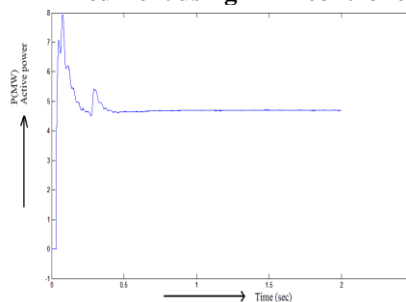

Fig.11.Simulation results with control method of active power (P) using PI-R controller.

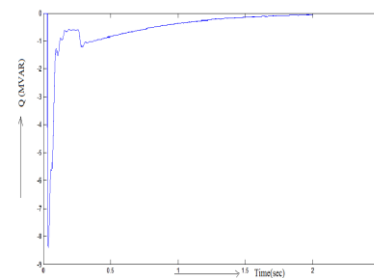

Fig.12 Simulation results with control method of reactive power (Q) using PI-R controller.

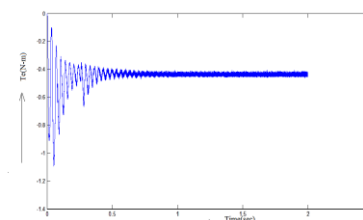

Fig.13.Simulation results with control method of torque using PI-R controller.

Three different control methods are simulated:

- 1) Method I (0.3-0.5s) : Convectional vector control without taking into account voltage unbalance for both GSC and RSC i.e., the R controllers are both disabled.
- 2) Method II(0.5-0.7s) : The RSC's R controller is enabled with the control target set to eliminating torque pulsation ,whereas the GSC's R controller is disabled.
- 3) Method III(0.7-0.8s): The RSC's and GSC's controllers are both enabled,with the RSC eliminating torque ripple and the GSC removing total active power output oscillation.

Table 4 Comparisons with Different Control Methods

	Method I	Method II	Method III
I_{total} unbalance (%)	8.19 19	4.89 9	4.95 5
I_r unbalance (%)	8.68 68	4.76 6	4.56 6
V_{dc} pulsation (V)	± 25 5	± 18 8	± 7 8
T_e pulsation (%)	± 8.6 .6	± 0.5 .5	± 0.5 .5
Q pulsation (%)	± 8.0 .0	± 0.5 .5	± 0.5 .5
P pulsation (%)	± 5.1 .1	± 5.0 .0	± 4.8 .8

As shown in Table 4 the comparison of three methods simulated on doubly-fed induction generator (DFIG). In method-I R controllers of rotor and grid side converters are disabled

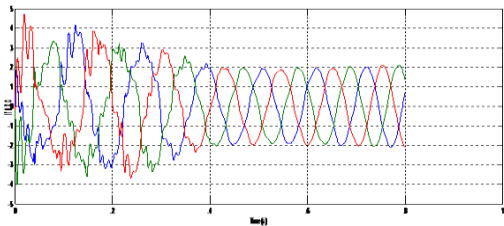

FIG 14 Simulation results with fuzzy logic controller methods of rotor current 5% voltage un balance and 1.2 p.u rotor speed

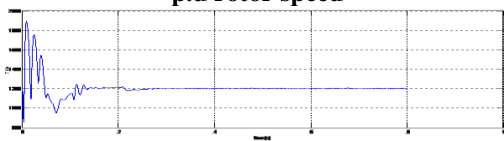

FIG 15 Simulation results with fuzzy logic controller methods of Vdc under 5% voltage un balance and 1.2 p.u rotor speed

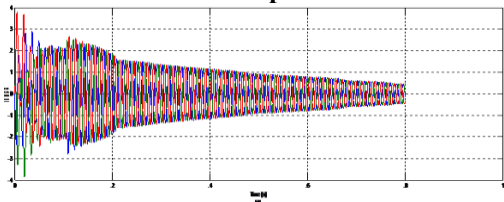

FIG 16 Simulation results with fuzzy logic controller methods of stator current under 5% voltage un balance and 1 p.u rotor speed

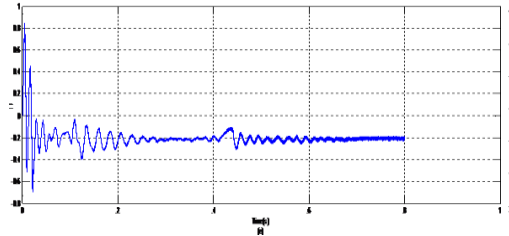

FIG 17 Simulation results with fuzzy logic controller methods of Torque under 5% voltage un balance and 1.2 p.u rotor speed

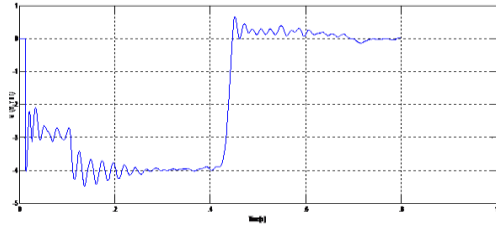

FIG 18 Simulation results with fuzzy logic controller methods of reactive power under 5% voltage un balance and 1.2 p.u rotor speed

Table 5. Comparison With Different Control Methods

	Method I	Method II	Method III	Method IV
I_{total} unbalance (%)	8.19	4.89	4.95	3.63
I_r unbalance (%)	8.68	4.76	4.56	2.48
V_{dc} pulsation (V)	± 25	± 18	± 7	± 6
T_e pulsation (%)	± 8.6	± 0.5	± 0.5	± 0.2
Q pulsation (%)	± 8.0	± 0.5	± 0.5	± 3.8
P pulsation (%)	± 5.1	± 5.0	± 4.8	± 1.2

COMPARISON OF PI-R AND FUZZY CONTROLLER

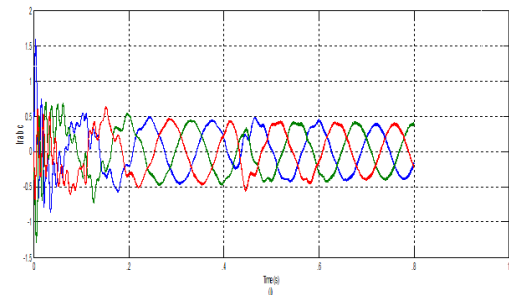

FIG 19 Simulation results control method of rotor current Igd under 5% voltage un balance and 1.2 p.u rotor speed using PI_R Controller

BY USING FUZZYCONTROLLER

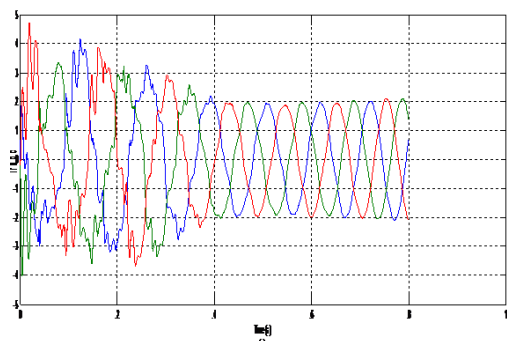

FIG 20 Simulation results fuzzy logic controller methods of rotor current I_{gd} under 5% voltage un balance and 1.2 p.u rotor speed

VI. CONCLUSION

Control and operation of a DFIG-based wind power generation system under unbalanced supply voltage conditions have been investigated in this thesis. A new coordinated control strategy for the RSC and GSC has been proposed. The RSC is controlled to eliminate the electromagnetic torque oscillation while the GSC compensates for the oscillation of the DFIG stator output active power to eliminate the oscillation in the total active power generated from the overall system. PI-R current controllers in the positive synchronous rotating reference frame have been proposed for regulating the GSC's and RSC's positive- and negative-sequence currents without involving the decomposition of positive- and negative-sequence components and Fuzzy-logic controller is used as its implementation is according to user defined rules.

REFERENCES

1. G.Saccomando, J.Svensson, A.Sannino, "Enhancing Voltage Disturbance Rejection For variable Pace Wind Turbines," *Ieee Trans. Essentialness Conversion*, Vol 17, No. Three, Pp 422-428, Sep 2002.
2. S.Muller, De Deicke, And R. W. De Doncker, "Doubly Fed Induction Generator Systems For Wind Mills," *Ind. Appl. Magazine*, Vol. 8, No.3, Pp 26-33, May Additionally/Jun.2002.
3. Three.J. B. Ekanayake, L.Holdsworth, X. G. Wu, And N. Jenkins, "Dynamic Modeling Of Doubly Fed Induction Generator Wind Generators," *Ieeetrans. Powersyst.*, Vol.18, No.2 Pp.803-809, Also Can 2003.
4. Johan Morren, W.H. De Haan, "Journey Via Of Wind Generators With Doubly Fed Induction Generator During A Voltage Dip," *Ieee Trans., On Power Conversion*, Vol.20, No.2 June 2005.
5. J.G.Slootweg, S.W. H. De Haan, H. Polinder, And W. L. Kling, "Widespread Version For Representing Variable Speed Wind Mills In Electricity Gadget Dynamics Simulations." *Ieee Trans. Energy Syst.*, Vol. 18, No. 1, Pp. One Hundred Forty 4-151, Feb. 2003

AUTHOR'S PROFILE



Mr. Karanam Deepak, is currently Assistant professor of Electrical and Electronics Engineering of G. Pullaiah College of Engineering and Technology, Kurnool, he has about 3 years of experience in teaching and research. He has published several research papers in journals of both international and national repute. He holds M.Tech degree from VNR Engineering college JNTUK, Guntur in the field of Power Electronics and Drives.



Mrs. Talari Aparna Received the M.Tech degree in Power Industrial Drives from JNTU-Ananthapuramu A.P, India. She has completed B.Tech degree in Electrical and Electronics Engineering from St. Johns college of Engineering and Technology, Yemmiganur, Kurnool (DT), A.P, India, in 2008. Currently working as a Assistant Professor in G. Pullaiah College of Engineering and Technology. And her areas of interest are Power Systems, Power Electronics, Electrical machines, Electrical Circuits. She has 6 years of teaching experience.



Mr. A.Suresh Kumar, is currently Asst. Professor of Electrical and Electronics Engineering Of G.Pullaiah college of Engineering and Technology, Kurnool, has has about 12 years of Experience in teaching and research. He holds B.tech and M.Tech degrees from S.V. Univerity Tirupati. He pursuing Ph.D in S. V. University Tirupati.



Mrs. P SIVA DEEPTHI Received the M.Tech in Power Electronics and Electrical Drives from St.Johns college of Engineering and Technology, Yemmiganur, Kurnool ,A.P, India. She has completed B.Tech degree in Electrical and Electronics Engineering from Gates institute of technology and Science, Gooty, Ananthapur (DT), A.P, India, in 2008. Currently working as a Assistant Professor in G. Pullaiah College of Engineering and Technology. And her areas of interest are Power Systems, Power Electronics, Electrical machines, Electrical Circuits. She has 7 years of teaching experience.



Mr. Y Hazarathaiiah was graduated in Electrical & Electronics Engineering from G. Pulla Reddy Engineering College, Kurnool in the year 2007. he received her M.Tech in Electrical Power Systems from Sri Kottam Tulasi Reddy Memorial College of Engineering , Mahaboob Nagar, in the year 2013. Presently he is working as Assistant Professor in Department of Electrical and Electronics Engineering at G. Pullaiah College of Engineering & Technology, Kurnool. he has 13 years of teaching experience. Her area of interest is Power Systems.