

Design and Simulation of Hybrid System using Cuckoo Mppt Technique

B. Srinivasa Rao, K. Kiran Kumar, D. Vijaya Kumar

Abstract: In contrast to present scenario, the renewable energy sources are accessible at no expense and produce power environmental friendly. Around early afternoon the WPS fulfills its heap and gives extra energy to the capacity or to the grid. On location energy generation is without a doubt went with minimization of ecological contamination, decrease of misfortunes in power system transmission and distribution. The main theme of this paper is to propose a demonstrating and planning of grid interfaced hybrid solar-wind energy system. This is an issue particularly in little powerful system because of the limitation on the inverter markets. Inverters which are used in these sorts of energy systems work on grid or off grid. In this investigation, a novel power the board methodology has been created by structuring a wind-PV mixture system to work both as a self-ruling system and as a grid-associated system. The structured Power Management Unit performs estimation from different focuses in the system and as per this estimation; it gives a compelling energy exchange to burdens and grid. The steadiness of the smaller scale grid, power quality and voltage direction is checked by Matlab and test results. This paper also presents a concept for effective utilization of Distribution Generation systems as a part of smart grid environment, to improve the system reliability by providing effective generation under islanding mode, and also to provide controlling services in the grid-tied mode. To meet this limitations, this proposed flexible system is implemented a control technique with power-voltage-current parameters.

Keywords: Power Management, Wind, Solar System, Particle Swarm Optimization, Cuckoo Search Algorithm, P&O MPPT Technique.

I. INTRODUCTION

A sustainable based smaller scale grid will be considered because the key declare manage the energy get to lack to finish energy poorness and the must modification the manners within which we manufacture and devour renewable energy models. For the most half, the sustainable based Energy Management System (EMS) is that the approach adequately and profitably the created power by every inexhaustible supply, for instance, PV, Wind and FC is employed. In order to meet the required [1] power demand in the present scenario grid interfaced renewable energy is the best solution for the distribution networks. The most important theme of smart energy system is to develop an economical EMS to cope with difficulties in the procedure for utility grid association whereas optimizing the value of the network operation and increasing the used power generated by every renewable unit of measurement with higher energy internal control for grid stability.

to realize these objectives; the subsequent necessary elements should be effectively used within the sensible grid; smart digital activity system and a good energy management system supported AI control rule to manage the energy flow and pass the information required for the energy management system [2]. The smart grid energy system provides the energy management capabilities to the system to receive and deliver power to the utility grid to meet the demand requirements. By the interconnection between hybrid system and grid system, there is a chance to raise the some PQ problems like synchronization, fluctuating system voltage in both magnitude and frequency, harmonic injections, frequency matching [3] at utility grid generation level and consumer level. Therefore, a battery system can be implemented in addition to the renewable sources as a backup purpose and provide reliable operation to the proposed hybrid system. To achieve this objective, the DG system should provide a flexibility and quality in gathering a broad assortment of control limits, for instance, steady trade among island and grid associated systems, reliable trade between dynamic/responsive power (PQ) and dynamic power/voltage (PV) [4] strategies for activity in the grid associated mode; force against islanding acknowledgment delays; offering irrelevant control-limit trading in the midst of mode move; and keeping up a different leveled control structure.

II. CONFIGURATION OF PROPOSED SYSTEM

HPS which comprises of wind energy system and solar system is intended to work either grid-associated or without grid association. The structure of HPS is shown in figure 1. In this paper, a double bridge rectifier is utilized to convert wind AC system to DC source in order to interconnect with the Solar system, later it applied to inverter for grid interconnection process.

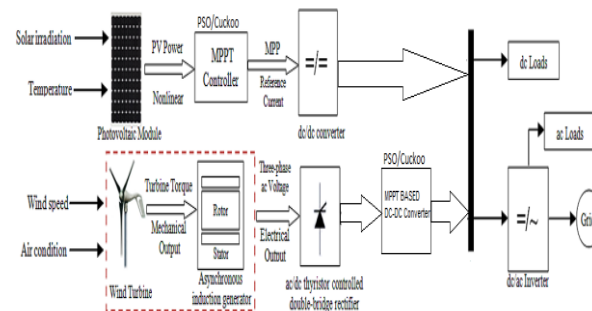

Figure 1: Architecture of MPPT based Wind-PV System

Revised Manuscript Received on October 20, 2019.

Dr. B. Srinivasa Rao, Assistant Professor, Department of EEE , Aditya Institute of Technology and Management, Tekkali, (AP), India.

Dr. K. Kiran Kumar, Professor, Department of EEE , Aditya Institute of Technology and Management, Tekkali, (AP), India.

Dr. D. Vijaya Kumar, Professor, Department of EEE, Aditya Institute of Technology and Management, Tekkali, (AP), India.

A. PV System:

Figure 2 shows the equivalent electrical PV system for obtaining DC parameters. PV system converts sun irradiance to electrical signal by photon process. In this, a mathematical analysis is presented to represent the physical PV system in mathematical model. The Solar Photovoltaic Current is expressed below. The performance characteristics of the PV system is presented in-terms of their I-V and P-V curves as shown in figure 3 and 4 [5].

$$I_{solar} = I_g - I_o \left[e^{\left[\frac{eV_T}{KFT_d} \right]} - 1 \right] - \frac{V_d}{R_p} \quad (1)$$

Where, I_g = Photocurrent

I_o = Diode Saturation Current

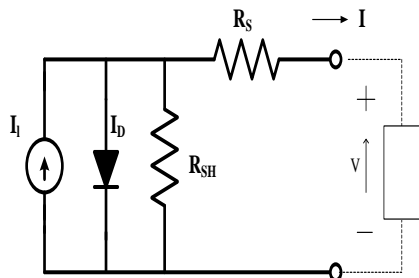

Figure 2: Solar Equivalent Circuit

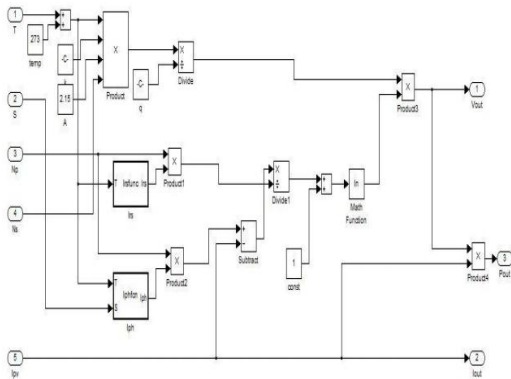

Figure 3: Mathematical Representation for PV System

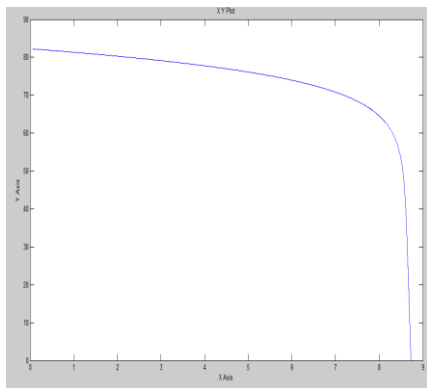

Figure 4 (a): Solar System I-V Curves

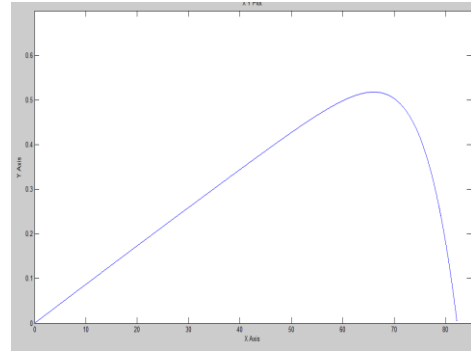

Figure 4 (b): Solar System P-V Curves

B. Wind Turbine:

Wind energy system is more flexible and reliable than PV System depends on climatic environmental conditions. Wind is freely available in environmental nature as compared to sunshine. The wind energy is converted in Mechanical Energy with the help of wind turbine and further it is converted to electrical with Generator [6]. The structure of wind turbine and its components are shown in figure 5. The performance of wind turbine system is presented in figure 6.

The kinetic energy causes rotation is given in

$$P_m = \frac{\rho A}{2} V_{wind}^3 C_p(\lambda, \beta) \quad (2)$$

Where, C_p is coefficient of Power.

Wind Turbine Diagram

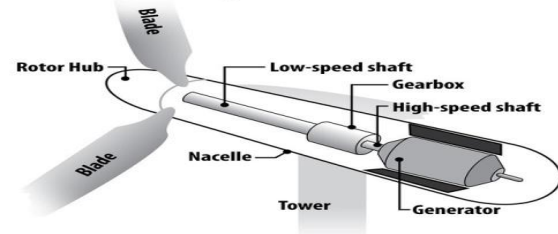

Figure 5: The Architecture of Wind Energy System

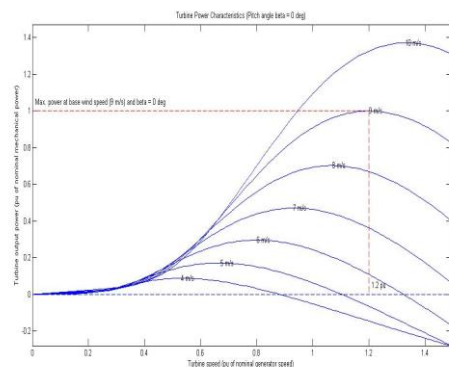

Figure 6: Wind System Characteristics

III. DESIGNING OF DOUBLE FED INDUCTION GENERATOR

DFIG plays a key role [6] in variable speed operating conditions with tolerance limit $\pm 30\%$ in synchronous speed. The back-back converters are used to control the DFIG system with rotor and grid powers. The basic architecture of DFIG with back-back converters are shown in figure 7.

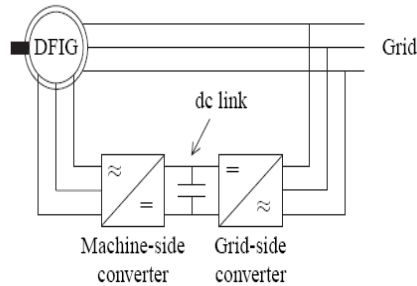

Figure 7: Architecture of DFIG System

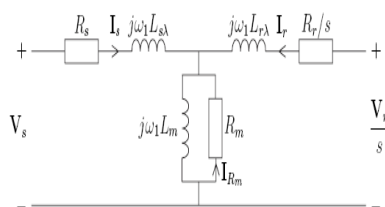

Figure 8: DFIG Equivalent Electrical System

DFIG based Wind Energy System

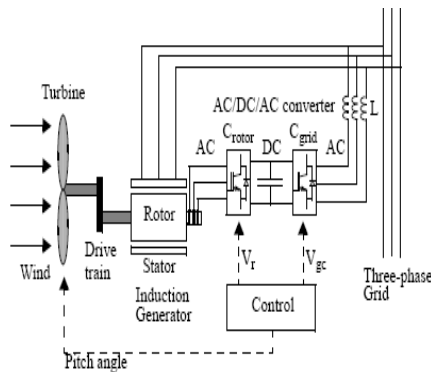

Figure 9: Wind-DFIG System

In this section, the generated mechanical power from the wind system is converted to electrical power with the help of DFIG system. The two converters in DFIG system is controlled with the help of reference signals generated by rotor and grid voltages, wind system pitch angle and DC link voltage between converters. The closed loop control diagrams for both converters are shown in figure 10 and figure 11.

C. Control Diagram for RSC Converter

The purpose of this control diagram is to control DFIG rotor active and reactive powers with the help of rotor regulation parameters and rotating rotor reference frame coordinates. The mathematical modelling for powers is obtained by writing KVL equation for rotor equivalent circuit as shown in figure 8.

$$\bar{V}_{sr} = \bar{I}_{sr} R_{sr} + \frac{d\psi_{sr}}{dt} \quad (3)$$

$$\bar{\psi}_{sr} = L_{sr} \bar{I}_{sr} + M \bar{I}_{ss} e^{-j\epsilon} \quad (4)$$

The Controller for RSC converter is shown in figure 10. This control diagram consists of two loops called inner and outer loop. The dq-axis reference current components which is required for inner loop are generated by the grid active and reactive powers in outer loop [7]. Inner-loop act as a current regulator to generate the reference direct and quadrature voltage signals, required for PWM generator.

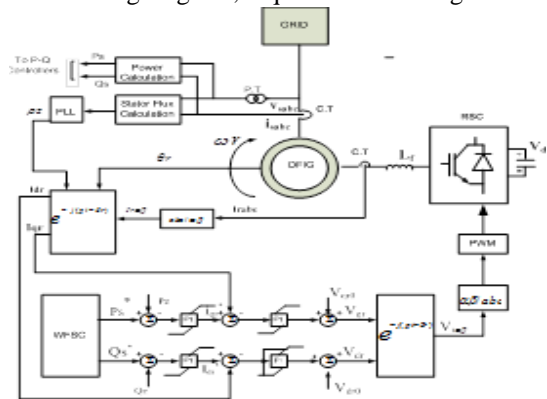

Figure 10: Rotor side Control Diagram for DFIG

D. Closed Loop Control Diagram GSC

Figure 11 shows the control diagram for DFIG system grid side converter, in order to control the system reactive power which is exchanged between grid and stator converters. Write the system equations for figure 8 using KVL principle.

$$v_r = I_r R_f + L_f \frac{dI}{dt} + v_{rg} \quad (5)$$

$$v_y = I_y R_f + L_f \frac{dI_y}{dt} + v_{yg} \quad (6)$$

$$v_b = I_b R_f + L_f \frac{dI_b}{dt} + v_{bg} \quad (7)$$

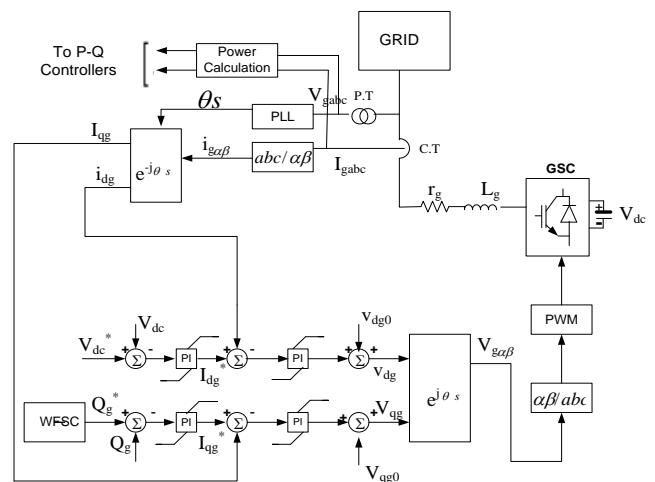

Figure 11: Control Diagram for GSC Converter

This diagram consists of two control loops. One is to control the DC link voltages of DFIG later it transmitted to direct axis voltage, the quadrature axis voltage is generated by controlling reactive powers of DFIG.

The active power of rotor is expressed as

$$P_r = \frac{3}{2}(v_{dr}i_{dr} + v_{qr}i_{qr}) = \frac{3}{2}[-s\omega_s L_m(i_{qs}i_{dr} - i_{ds}i_{qr}) + r_r(i_{dr}^2 + i_{qr}^2)] \quad (8)$$

E. Control Structure for Proposed Micro-Grid System

Figure 12 shows the control structure for proposed small scale grid network which is utilized for remunerating the outer aggravations brought about by the system. Furthermore, the inside aggravations which is caused because of exchanging control works among grid and islanding modes is additionally wiped out by utilizing this progressive control system, and to accomplish adaptable and strong task of appropriation age units [8-9]. This controller likewise decreases the undesired voltage varieties which is created by appropriate changing tasks from current-voltage controlled converters.

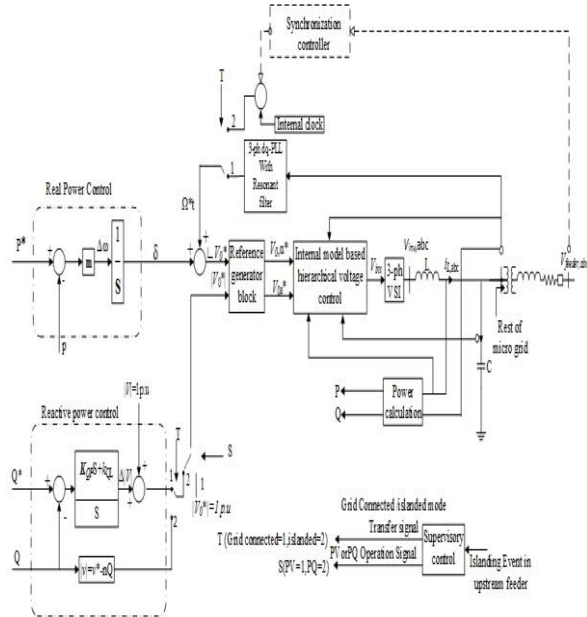

Figure 11: Control Structure for micro-grid system

F. Control Structure

The power management strategy between pv-wind and grid system is shown in the following equation and implemented the control diagram as shown in figure 12.

$$P_{act} = P_{wind} + P_{pv} - P_{load} \quad (9)$$

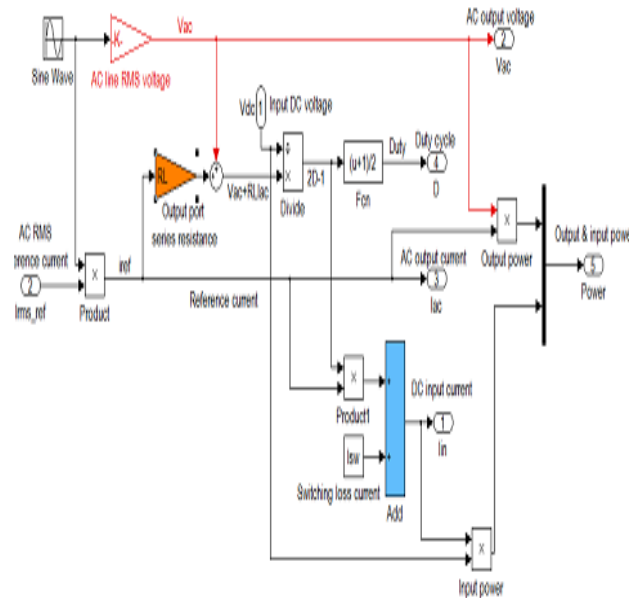

Figure 12: Hybrid System Proposed Control Strategy

G. Partical Swarm Optimization:

It is a bio spurring processing apparatus. It is created dependent on the exercises of winged creatures, angle, and different creatures. It is a vigorous stochastic showcasing system dependent on the development and knowledge of swarms [10]. PSO applies the idea of social discussion for critical thinking.

Velocity function

$$V_{r(k+1)} = V_{r(k)} + t_1(P_r - X_{r(k)}) + t_2(G - X_{r(k)}) \quad (10)$$

Analysis of PSO Technique:

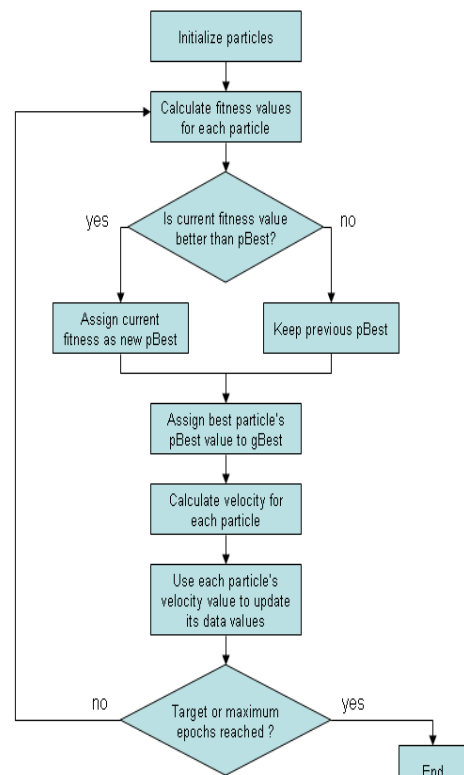

Figure 13: Algorithm for PSO MPPT

H. Cuckoo Search Algorithm

Many nature's enlightened developmental calculations have been produced for improvement in the previous couple of years. These calculations more often than not work dependent on an irregular hunt in some adequate inquiry locale relying upon the issue to be improved. Be that as it may, the pursuit isn't really irregular in light of the fact that there will be some instrument in the calculation which aids the hunt so the arrangement vector gets improved with emphases. Two essential fundamental attributes of these advanced meta heuristic calculations are increase (Exploitation) and enhancement (investigation). The procedure of the cuckoo search method is appeared in figure 14.

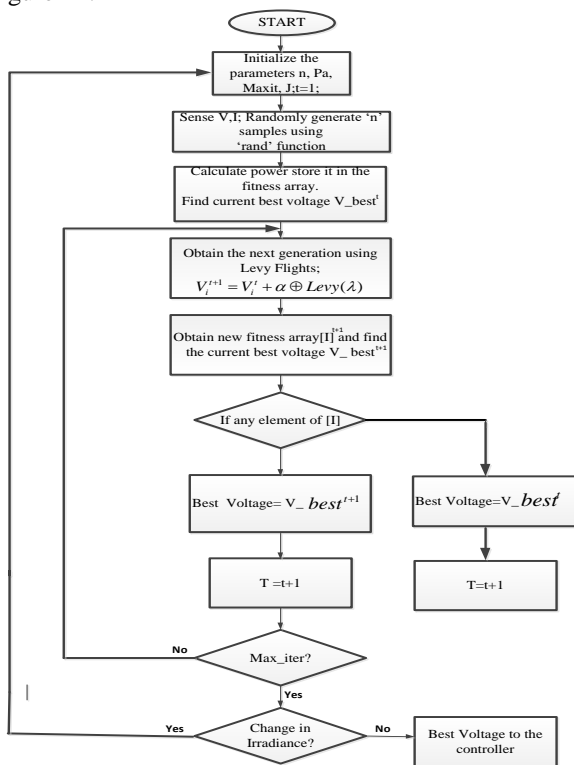

Figure 14: Flowchart for Cuckoo MPPT

In the event that the examples don't combine, all the power estimations of the relating tests are estimated and are put away in the wellness cluster [10]. By assessing the cluster, the example with most noteworthy power is picked as the best example. From there on every single other example are compelled to go towards this best esteem. The progression sizes are determined by playing out the Levy trip as depicted by conditions.

$$V_i^{t+1} = V_i^t + \alpha \oplus \text{levy}(\lambda) \quad (11)$$

$$S = \alpha_q (V_{bt} - v_j) \oplus \text{le}(\lambda) \quad (12)$$

IV. MATLAB EXPERIMENTAL RESULTS

The hybrid pv-wind system with different MPPT controllers is practically tested and verified using MATLAB/Simulink software tool.

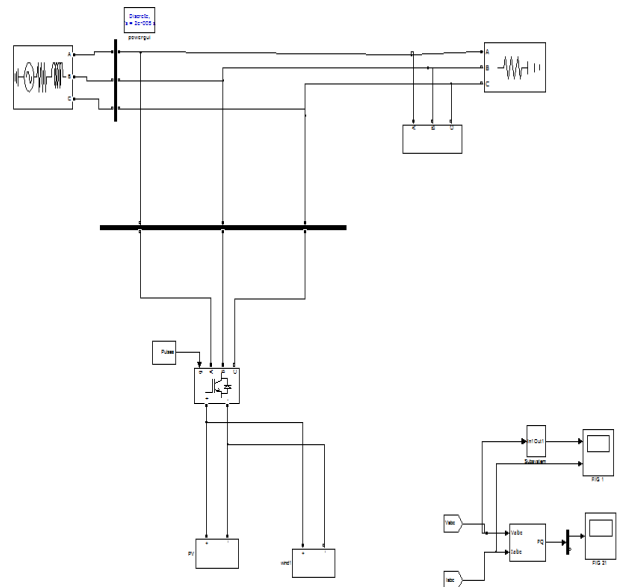

Figure 15: Simulation Diagram for Proposed PV-Wind Hybrid System

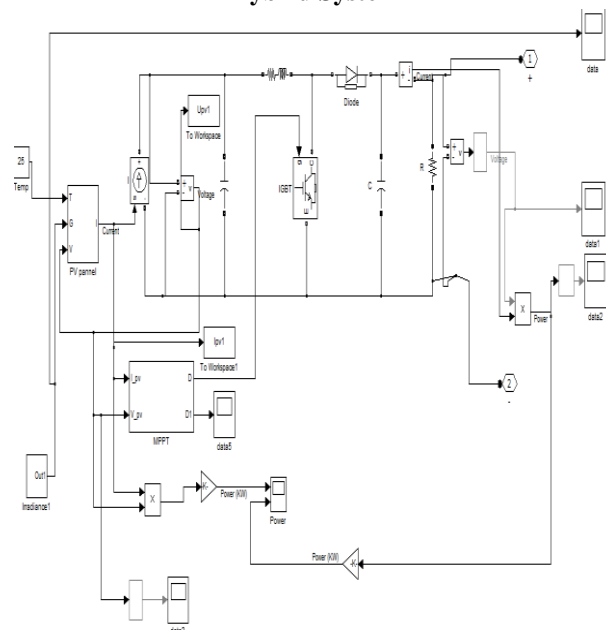

Figure 16: Simulation Model for Designing of PV System

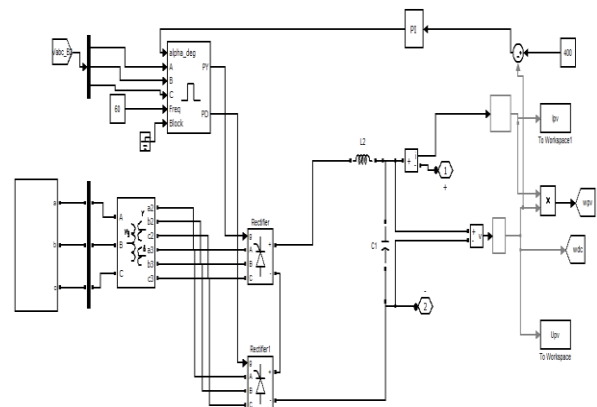

Figure 17: Simulation for Designing of Wind Turbine System

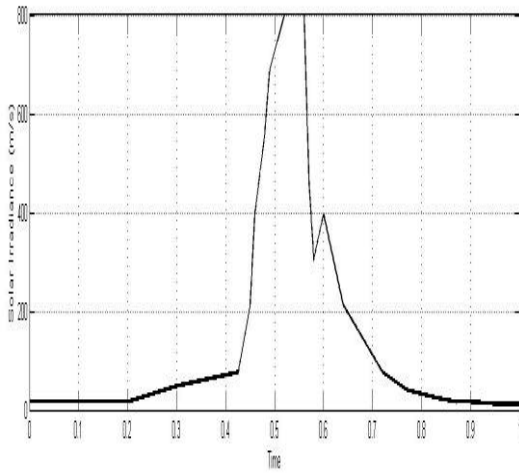

Figure 18: Experimental Waveform for PV System Irradiance

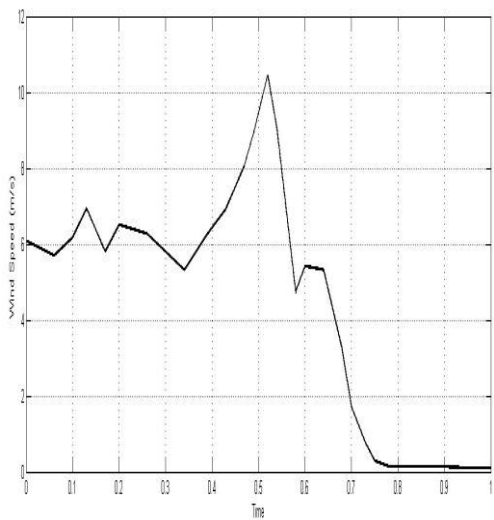

Figure 19: Experimental Waveform for Wind System Wind Speed

Figure 18 and 19 shows the Experimental Waveform for irradiance and wind speed to the corresponding PV and Wind System respectively. In this paper, variable irradiance and Wind speed are considered to observe the performance of the hybrid system.

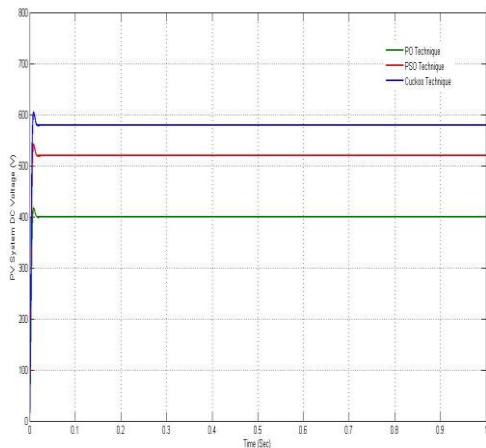

Figure 20: Experimental Waveform for PV System DC Voltage under Three MPPT Techniques

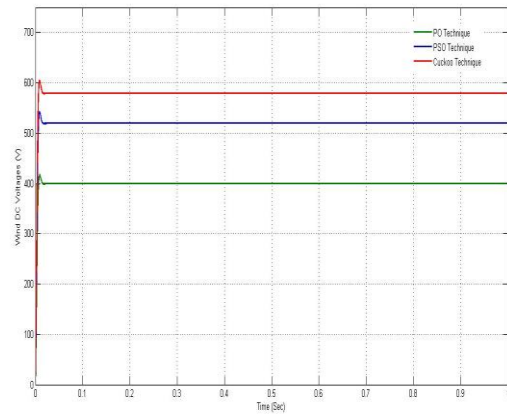

Figure 21: Experimental Waveform for Wind System DC Voltage under Three MPPT Techniques

This proposed Hybrid system is implemented and verified under three different MPPT Techniques like PO, PSO and Cuckoo algorithms. The Experimental Waveforms for DC Voltages of PV and Wind Systems are shown in figure 20 and figure 21.

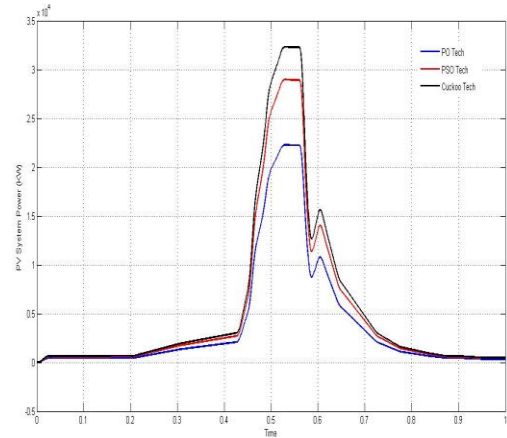

Figure 22: Experimental Waveform for PV System Power under Three MPPT Techniques

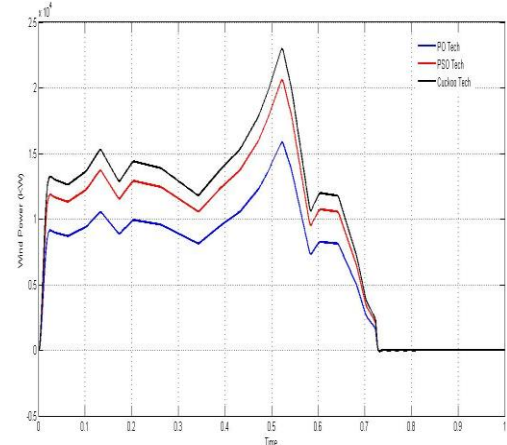

Figure 23: Experimental Waveform for Wind System Power under Three MPPT Techniques

Figure 22 and figure 23 shows the Experimental Waveform for Wind and PV System Powers under three MPPT techniques.

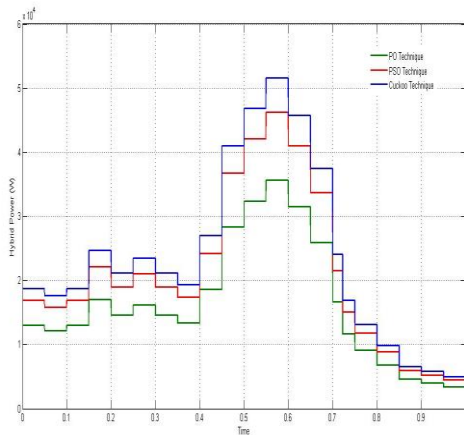

Figure 24: Experimental Waveform for Hybrid System Power under Three MPPT Techniques

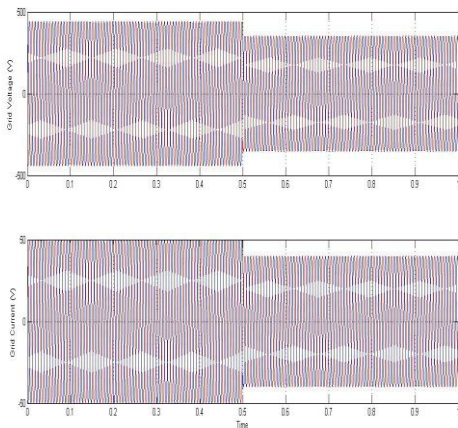

Figure 25: Experimental Waveform for Islanding Mode

This paper also verified under islanding condition. In this paper at $t=0.5$ Secs, the grid system is scheduled to islanding mode and at this condition the performance of system is observed. The Experimental Waveform for grid voltage, current and Powers are shown below.

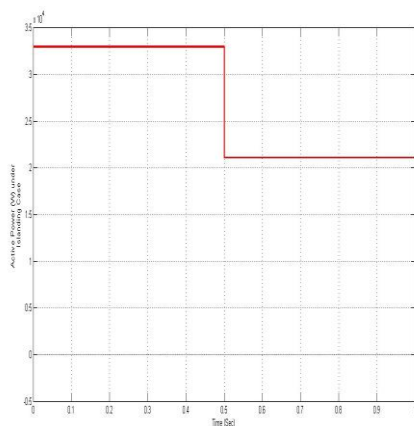

Figure 26: Experimental Waveform for Grid System Power under Islanding Condition

Table 1: Comparative Results for various powers under different MPPT Controllers

S.No	Type of MPPT	PV Power (KW)	Wind Power (KW)	Hybrid System Power (KW)
1	P&O	23	16	35.8
2	PSO	28	21	46.3
3	Cuckoo	33	24	51

Table 2: Solar System Parameters

Parameter	Value
System Base Speed	9 m/s
Maximum Power at Base speed	1 p.u
Turbine Coefficients	[0.5176, 116, 0.4, 5, 21,0.0068]
Coefficient of Power	0.48 (p.u.) for $[\beta = 0^\circ, \lambda = 8.1]$

Table 3: Wind System Parameters

Parameter	Value
PV Panel maximum allowable Power	225W
PV panel OC Voltage	36.88V
Voltage at Maximum Power	29.76V
PV panel SC Current	8.27A
Current at Maximum Power	7.55A

V. CONCLUSION

A Power Management Strategy for Hybrid Grid interconnected PV-Wind Energy system is proposed in this paper. In this, the proposed hybrid system is implemented using different MPPT controllers to provide the effective performance of the system. The proposed PSO and Cuckoo based MPPT calculations involves the system parts and furthermore balance the power stream. The accessible power from the PV item is profoundly dependent on solar radiation. Three strategies; P&O, PSO and Cuckoo technique.

Design and Simulation of Hybrid System using Cuckoo Mppt Technique

The dynamic execution of the proposed energy the executives system dependent on MPPT with its control and correspondence system is tried tentatively and utilizing SIMULINK under genuine record of climate examples and load conditions. The near outcomes for the proposed system with various MPPT controllers is appeared.

REFERENCES

1. Ligade Gitanjali Vasant, V. R. Pawar, 'Optimization of solar-wind energy system power for battery charging using MPPT', 2017 International Conference on Energy, Communication, Data Analytics and Soft Computing (ICECDS), 21 June 2018.
2. Ibrahim Elsayed ; Ibrahim Nassar ; Fatma Mostafa, "Optimization and economic evaluation of small scale hybrid solar/wind power for remote areas in Egypt", 2017 Nineteenth International Middle East Power Systems Conference (MEPCON), Feb-2018.
3. Ch. Mangeshkar, K. Padma, " Grid Interconnection of Fuel Cell at distribution level and power quality improvement of a Non-Linear Load by using DSTATCOM" IJESI, Volume 8, issue-05, series-1, May 2019.
4. Man Xu ; Linlin Wu ; Hui Liu ; Xiao Wang, "Multi-objective optimal scheduling strategy for wind power, PV and pumped storage plant in VSC-HVDC grid", The Journal of Engineering, Volume: 2019 , Issue: 16 , 3 2019.
5. Shailendra Kumar Tiwari ; Bhim Singh ; Puneet Kr. Goel, "Design and Control of Autonomous Wind-Solar System With DFIG Feeding 3-Phase 4-Wire Loads", IEEE Transactions on Industry Applications, Volume: 54 , Issue: 2 , March-April 2018.
6. Adedayo M. Farayola ; Yanxia Sun ; Ahmed Ali, "ANN-PSO Optimization of PV Systems Under Different Weather Conditions", 2018 7th International Conference on Renewable Energy Research and Applications (ICRERA).
7. Abdel-Raheem Youssef, "Wind Speed Estimation MPPT Technique in Grid-Connected Wind Energy Conversion System." 2018 Twentieth International Middle East Power Systems Conference (MEPCON).
8. Sérgio Augusto OLiveira da Silva ; Leonardo Poltronieri Sampaio ; Fernando Marcos de Oliveira, "Feed-forward DC-bus control loop applied to a single-phase grid-connected PV system operating with PSO-based MPPT technique and active power-line conditioning", IET Renewable Power Generation, Volume: 11 , Issue: 1 , 1 11 2017.
9. Mohammed Fdaili ; Ahmed Essadki ; Mohamed Nadour ; Tamou Nasser, "Comparative Study of MPPT and Pitch Angle Control Strategies for a Wind Energy Conversion System" 2017 International Renewable and Sustainable Energy Conference (IRSEC).
10. Chakkarapani Manickam ; Guru Raghav Raman ; Guru Praanesh Raman ; Saravana Ilango Ganesan, "A Hybrid Algorithm for Tracking of GMPP Based on P&O and PSO With Reduced Power Oscillation in String Inverters", IEEE Transactions on Industrial Electronics, Volume: 63 , Issue: 10 , Oct. 2016.

AUTHORS PROFILE



Dr. B. Srinivasa rao working as assistant professor in the department of EEE, Aditya Institute of Technology & Management, Tekkali, AP, India. He obtained his Bachelor of Technology from GOKUL Institute of Technology in 2010, PG degree from DADI Institute of Technology in 2013 and Ph.D. from Jodhpur National University in the year 2017, India. He has 5 years of teaching experience and published many national and international journals.



Dr. Kalyana Kiran Kumar was awarded Ph.D., and M.E. degrees in 2015 and 2004 respectively from Andhra University, Visakhapatnam, India. Currently he is working as a Professor in the Department of Electrical and Electronics Engineering, AITAM College of Engineering, TEKKALI, Andhra Pradesh. He has vast teaching experience of 16 years. He is a member of IETE, ISTE and IAENG (HK). He is a Reviewer of Journal of Institute of Engineers Series B and International Journal of Power and Energy Conversion. His Research interests include large scale systems,

designing of controllers, Interval systems, Fractional systems and nonlinear systems.



Dr. D. Vijaya Kumar currently working as a professor and head in the department of EEE, Aditya Institute of Technology & Management, Tekkali, AP, India. He obtained his Bachelor of Technology in the year 1997 from Andhra University, Master of Technology in 2000 from AU, and Ph.D from Andhra University in the year 2004, AP, India. He has 20 years of teaching experience and published many national and international journals.

