

Enhancement of Voltage Profile by Optimal Placement of Distributed Generators with UPFC in Distribution Networks

Rudresh B. Magadum, D.B.Kulkarni

Abstract: *The Distributed generation and fast operating power electronic devices are attracting more attention due to their effective solution for improvement in the voltage profile, to meet the increasing power consumption, reduction in the power loss, enhancement in the power transfer capacity of the transmission lines, reducing the overloading of the entire network. The optimal placement of DG and FACTS devices plays key role in improvement of the network reliability and voltage stability. In this paper exhaustive load flow analysis is carried out for optimal placement of DG and UPFC. The proposed method is tested on 40 bus distribution network. The obtained results are satisfactory in terms of improvement in the overall performance of the distribution network.*

Index Terms: *Distributed generators; voltage profile; unified power flow controller; power loss; distribution network; reliability; exhaustive load flow analysis; transmission capacity.*

Nomenclature:

DG	Distributed generation
UPFC	Unified Power Flow Controller
P_{Loss}	Total power loss in the network
N	Number of transmission lines
G_k	Conductance of k^{th} node connects between nodes m and n.
δ_m, δ_n	Voltage angle magnitudes at nodes m and n
SVC	Static Var Compensator
FKBC	Fuzzy Knowledge based controller
R_n	Resistance of the n^{th} branch
V_{max}	Maximum Voltage
UPQC	Unified Power Quality Conditioner
TCSC	Thyristor Controlled static Compensator
I_n	Current flowing in the branch n
V_m, V_n	Voltage magnitudes at bus m and n
RDS	Radial Distribution Systems
V_{min}	Minimum Voltage
k,m,n	Nodes
FACTS	Flexible AC Transmission Systems
MW	Mega watts
SSSC	Static Synchronous Series Compensator
LFA	Load Flow Analysis

I. INTRODUCTION

Now a day's electricity is also acting as a one of the basic need in the modern life. Every year 8-12% increased in the power consumption makes over loading of the generation, transmission and distribution [1-4]. With expansion of power

system network also creates some issues like over loading of line. Droop in the voltage profile, transient instability, line outages, more power losses etc [5-7]. Although old electrical infrastructure makes weak electrical network, with small disturbance may leads to failure of the entire grid. Because of these reasons, power system is gaining more attention for new innovations to address these issues [8-11].

Many researchers are working in different angles to address these issues by incorporating new controlling mechanisms, installing fast operating efficient devices, upgradation of network, interconnecting potential available sources etc [12-15].

In this paper on site power generation with UPFC is used to improve the voltage followed by power loss reduction. Generating 20-25% of the existing power close to the load centers reduces the over loading of the network. Connecting optimal size with desirable location of DG makes enhancement in the voltage profile reducing current in the network i.e., reducing the I^2R losses. Installation of UPFC also boosts the voltage profile and helps to monitor the power flow in the network. The combination of both UPFC and DG will helps to increase the overall efficiency of the network. The 40 bus distribution network is chosen as test network. The obtained results are better in terms of efficient, stable and reliable operation of the network.

II. ORGANIZATION OF THE PAPER

Section III discusses the methodology. Section IV introduces the simulation results and discussions. Section V discusses the conclusion.

III. METHODOLOGY

The main objectives of DG and UPFC placement are maximization of the voltage profile with power loss reduction. The power loss in the network is given by,

$$\text{Min}\{P_{Loss}\} = \text{Min}\left\{\sum_{k=1}^N (V_m^2 + V_n^2 - 2V_m * V_n * \cos(\delta_m - \delta_n))\right\} \quad (1)$$

Revised Manuscript Received on October 05, 2019

Rudresh. B. Magadum, Research Scholar, Department of Electrical and Electronics Engineering, KLS Gogte Institute of Technology, Belagavi-590008, Karnataka, India.

Dr. D.B.Kulkarni, Professor, Department of Electrical and Electronics Engineering, KLS Gogte Institute of Technology, Belagavi-590008, Karnataka, India.

IV. RESULTS AND DISCUSSIONS

For DG placement fuzzy knowledge based controller is used. The 40 bus system consists of two generators placed at bus 24 and 40 with 1.0 p.u. specified voltage and also it is connected with 14 transformers, 27 transmission lines and total 19 loads are connected across the network with total load of 25.89MW of active power and 5.9MVar of reactive power. The LFA is carried out using MiPower software. The single line diagram of 40 bus system is as shown in the Fig.1. The system is converged in four iterations with tolerance of 0.001. The LFA results in terms of line flows with line losses and transformer flow and transformer losses are as shown in the Table.1 and Table 2 respectively.

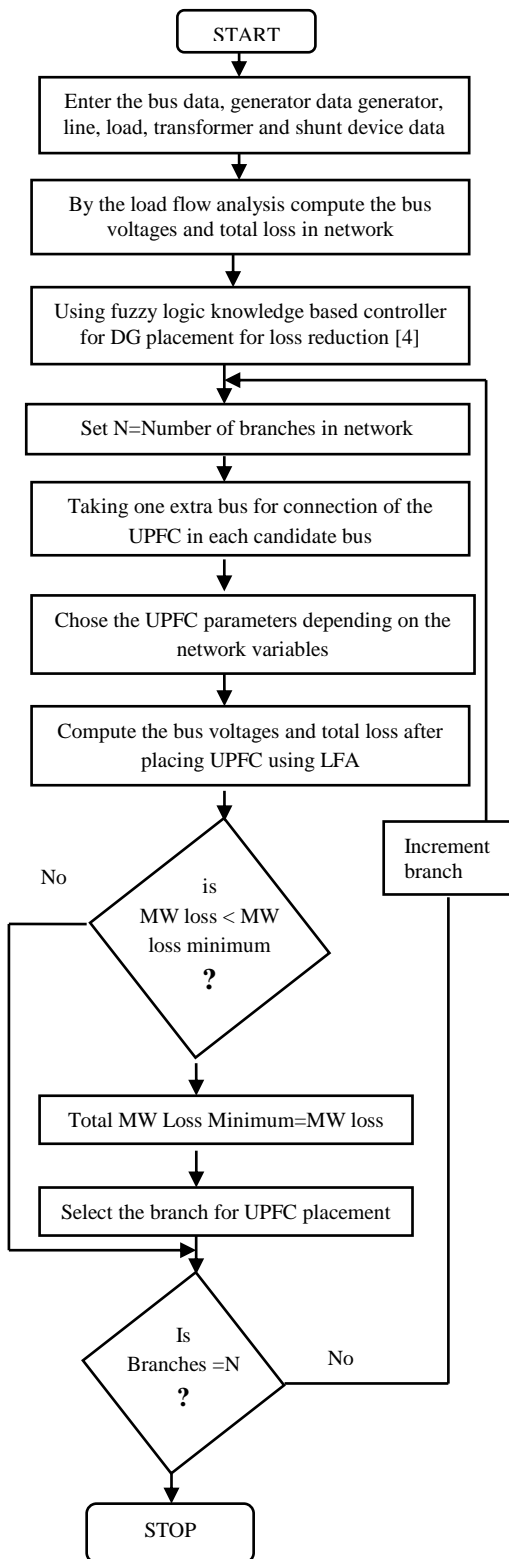

Fig.1 Flow chart for DG and UPFC placement

Fig.1 shows the flow of optimal placement of DG and UPFC placement for power loss reduction with improvement of the voltage stability.

Table.1 Line flows and line losses

From bus	To bus	Forward power flow		Power loss	
		Real Power in MW	Reactive Power in MVar	Real Power in MW	Reactive Power in MVar
3	9	2.444	1.454	0.0039	0.0014
3	5	1.519	0.975	0.0025	0.0003
3	26	1.100	0.604	0.0025	0.0003
3	6	4.544	3.059	0.0085	0.0037
4	15	3.251	2.133	0.0131	0.004
4	7	3.373	2.678	0.0041	0.0018
4	8	7.207	-5.392	0.0066	0.0083
4	24	-5.781	1.812	0.0378	0.024
9	25	1.103	0.499	0.0064	0.0008
9	12	1.337	0.954	0.0011	0.0001
10	13	1.336	0.945	0.0012	0.0002
10	27	-1.336	-0.945	0.0028	0.0004
6	14	3.273	2.159	0.032	0.0098
7	27	2.761	2.231	0.0055	0.002
7	16	0.607	0.445	0.0015	0.0002
17	22	0.120	0.070	0.0001	0.0001
18	23	0.120	0.070	0.0001	0.0001
24	31	1.821	1.319	0.0038	0.0005
24	32	0.86	0.562	0.0011	0.0001
28	38	0.068	-0.184	0.0001	0.0001
28	33	0.25	0.15	0.0003	0.0002
29	38	0.058	-0.083	0.0001	0.0000
29	34	0.10	0.05	0.0001	0.0000
30	38	0.376	0.518	0.0015	0.0014
30	35	0.25	0.15	0.0003	0.0002
40	1	9.723	6.84	0.0214	-0.0092
40	2	8.105	1.564	0.0103	-0.031



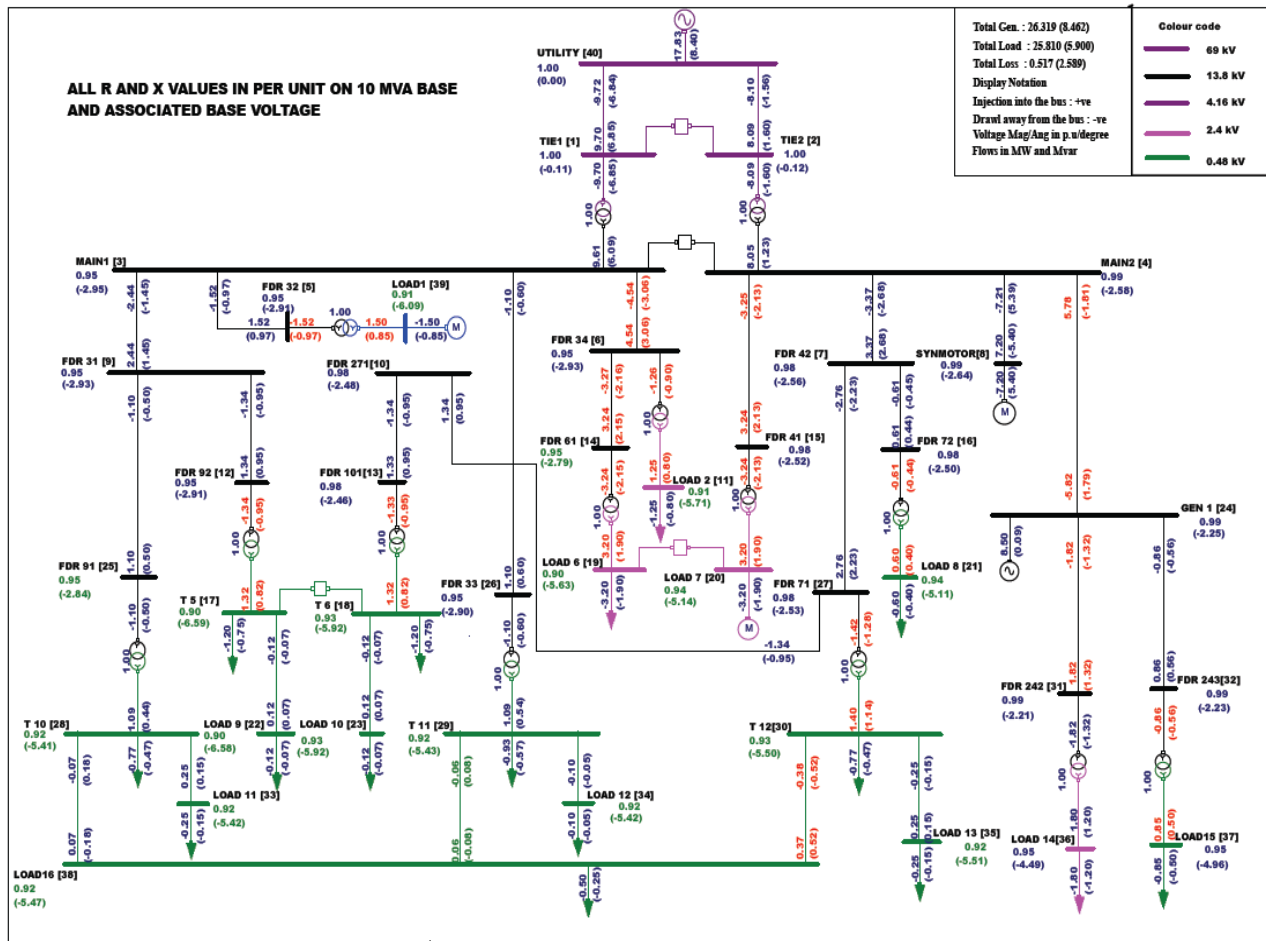

Fig.1 Single line diagram of 40 bus system

Table.2 Transformer power flow and transformer losses

From bus	To bus	Forward power flow		Power loss	
		Real Power in MW	Reactive Power in MVar	Real Power in MW	Reactive Power in MVar
1	3	9.702	6.849	0.0947	0.757
2	4	8.094	1.595	0.0456	0.364
5	39	1.517	0.974	0.0166	0.1244
6	11	1.262	0.897	0.0121	0.0969
12	17	1.336	0.954	0.0157	0.1336
13	18	1.335	0.945	0.0147	0.1252
14	19	3.241	2.149	0.0413	0.2489
15	20	3.238	2.129	0.038	0.2289
16	21	0.606	0.445	0.0056	0.0449
25	28	1.097	0.498	0.0088	0.0618
26	29	1.098	0.604	0.0095	0.0662
27	30	1.417	1.283	0.0207	0.1449
31	36	1.817	1.319	0.017	0.1186
32	37	0.859	0.562	0.0088	0.0619

Fig.2 shows the voltage magnitude in p.u. at each bus. From the LFA analysis it is observed that, minimum voltage in the network is 0.902p.u. at bus 17 and maximum voltage value is 1 p.u. at generators buses i.e., bus 24 and 40. If the voltage profile is low then loads will draw the more reactive power and more power loss will be taken place in terms of I^2R .

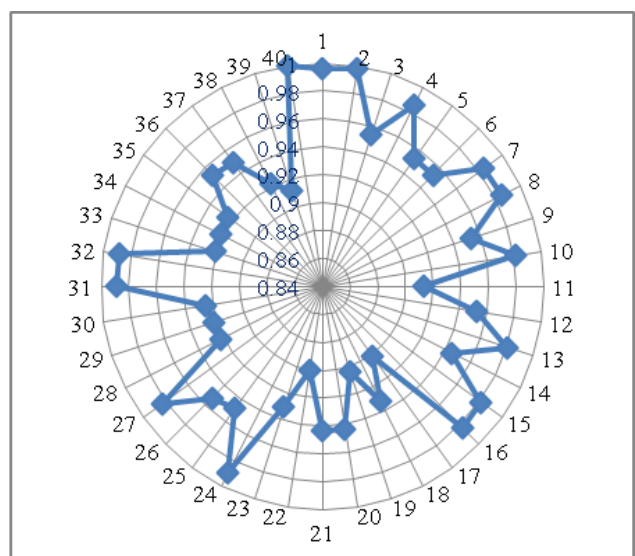

Fig.2 Voltage profile of 40 bus system

Table.3 Voltage value in p.u in different scenarios

Bus No.	Voltage in p.u.	After connecting DG at bus 5	Connecting UPFC between 6 and 14	DG with UPFC
1	0.9965	0.9968	0.9966	0.9986
2	0.9983	0.9986	0.9988	0.9995
3	0.9545	0.9621	0.9556	0.9685
4	0.9853	0.9862	0.9872	0.9912
5	0.9533	1.0000	0.9539	1.0000
6	0.9530	0.9823	0.9581	0.9923
7	0.9843	0.9852	0.9845	0.9902
8	0.9852	0.9864	0.9853	0.9881
9	0.9532	0.9632	0.9534	0.9762
10	0.9812	0.9824	0.9814	0.9886
11	0.9134	0.9256	0.9238	0.9345
12	0.9526	0.9538	0.9624	0.9685
13	0.9806	0.9825	0.9828	0.9845
14	0.9452	0.9564	0.9586	0.9614
15	0.9819	0.9835	0.9886	0.9884
16	0.9826	0.9834	0.9884	0.9896
17	0.9020	0.9120	0.9248	0.9312
18	0.9317	0.9412	0.9416	0.9514
19	0.9045	0.912	0.9213	0.9285
20	0.943	0.9435	0.9445	0.9506
21	0.9429	0.9534	0.9438	0.9587
22	0.9010	0.9200	0.9023	0.9289
23	0.9309	0.9386	0.9352	0.9408
24	1.0000	1.0000	1.0000	1.0000
25	0.9483	0.9496	0.9495	0.9587
26	0.9527	0.9623	0.9581	0.9728
27	0.9827	0.9828	0.985	0.9886
28	0.9228	0.9345	0.9256	0.9312
29	0.9231	0.9332	0.9235	0.9412
30	0.9261	0.9345	0.9268	0.9345
31	0.9885	0.9894	0.9886	0.9912
32	0.989	0.9892	0.9895	0.9990
33	0.9216	0.9218	0.9315	0.9338
34	0.9225	0.9318	0.9321	0.9412
35	0.9249	0.928	0.9312	0.9387
36	0.9526	0.955	0.9628	0.9689
37	0.9503	0.9526	0.9618	0.9687
38	0.9231	0.9285	0.93.00	0.9405
39	0.9118	0.9218	0.9216	0.9312
40	1.0000	1.0000	1.0000	1.0000

Table.3 shows the voltage comparison of different conditions. In base case it is observed that, the minimum voltage 0.9010p.u. at bus number 22 and maximum voltages in the network is 1.0 at generator buses. The analytical method is used for the DG placement considering the acceptable voltage enhancement with power loss minimization. By connecting appropriate size of the DG at bus-5, it is observed 0.912 p.u. as minimum voltage at bus number 22. The voltage profile in the network is improved upto 5-10%.

The UPFC placement also carried out, to verify the effectiveness in the voltage profile by analytical method. It is observed that, line between 6 and 14 is weakest point in the network. Hence it is chosen for the UPFC connection taking bus 41 as a UPFC connecting bus. After connecting UPFC the minimum voltage in the network is 0.9023p.u. at bus-22. The combination of DG with UPFC is also tested and it is observed that acceptable improvement in the voltage profile with reduction in the total power loss of the distribution network.

Fig.3 shows the voltage comparison of 40 bus distribution network. Four cases are considered here mainly base case with UPFC, with DG and combination of DG-UPFC. In all three cases enhancement of the voltage profile is observed. Connecting combination of DG with UPFC increases overall efficiency of the network with maintaining the voltage stability in the network.

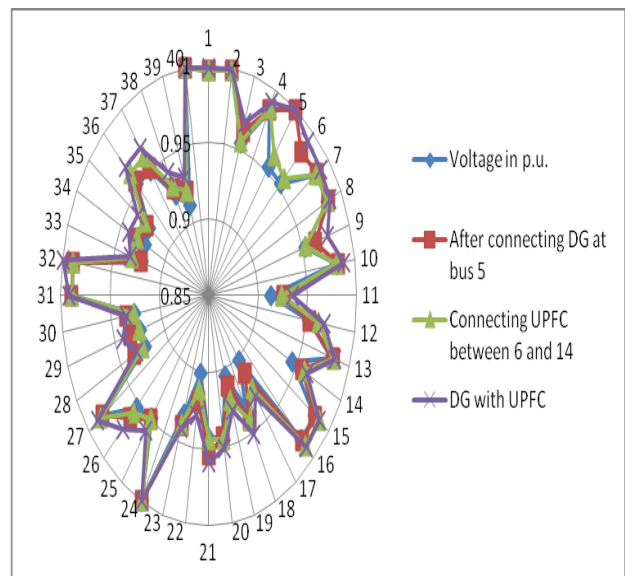

Fig.3 Voltage profile in p.u. base case with DG, UPFC and combination of DG-UPFC

V. CONCLUSION

In this paper improvement of the voltage profile with total power loss is minimized using optimal placement of DG with UPFC. The MiPower software tool is used for the analysis. The 40 bus distribution network is used as test system. The obtained results are very effective for the stable and healthy and efficient operation of the distribution network.

REFERENCES

1. K.R.Padiyar, "FACTS controllers in transmission and distribution", New age international publishers, Edition 2007.
2. Singh, Bindeshwar, Payasi, R.P., Shukla, Vipul, "A taxonomical review on impact assessment of optimally placed DGs and FACTS controllers", Energy Rep. 3, 94-108.
3. Duong Quoc Hung, Nadarajah Mithulananthan, R. C. Bansal, "Analytical Expressions for DG Allocation in Primary Distribution Networks", IEEE Transactions on Energy Conversion, Vol. 25, No. 3, September 2010, pp.814-820.



4. Rudresh B Magadam, Sateesh N Dodamani and D.B.Kulkarni, "Optimal Placement of Unified Power Flow Controller (UPFC) using Fuzzy Logic", IEEE international conference, ICEES 2019.
5. Rudresh B Magadam, D.B.Kulkarni, "Optimal Placement and Sizing of Multiple Distributed Generators using Fuzzy Logic", IEEE international conference ICEES-2019.
6. Rudresh.B.Magadam, Dr.D.B.Kulkarni, "Power Loss Reduction by Optimal Location of DG using Fuzzy Logic", IEEE conference ICSTM-2015, pp.338-343.
7. Mostafa F. Shaaban, Yasser M. Atwa, Ehab F. El-Saadany, "DG Allocation for Benefit Maximization in Distribution Networks", IEEE Transactions on Power Systems, Vol. 28, No. 2, May 2013,pp 639-649.
8. Mohammad H. Moradi, Mohamad Abedini, and S. Mahdi Hosseini, "A Combination of Evolutionary Algorithm and Game Theory for Optimal Location and Operation of DG from DG Owner Standpoints", IEEE Transactions on Smart Grid, Vol. 7, No. 2, March 2016,pp.608-616.
9. Fahad S. Abu-Mouti, M. E. El-Hawary, "Optimal Distributed Generation Allocation and Sizing in Distribution Systems via Artificial Bee Colony Algorithm", IEEE transactions on power delivery, vol. 26, no. 4, october 2011, pp-2090-2101.
10. U.Sultana, AzharB.Khairuddin, M.M.Aman , A.S.Mokhtar, N.Zareen , "A review of optimum DG placement based on minimization of power losses and voltage stability enhancement of distribution system", Renewable and Sustainable Energy Reviews 63(2016)363–378
11. Rudresh B Magadam, D.B.Kulkarni, "Optimal Placement of Distributed Transformer with STATCOM to Enhance the Efficiency of the Distribution Networks", International Journal of Recent Technology and Engineering, Volume-8.Issue-2, pp.3720-3725, July-2019.
12. P.S. Georgilakis, and N.D.Hatzigiorgiou, Optimal distributed generation placement in power distribution networks: models, methods, and future research. *IEEE Transactions on Power Systems*, vol. 28, no. 3, pp.3420-3428, 2013.
13. Y. M. Atwa, E. F. El-Saadany, M. M. A. Salama, and R. Seethapathy, "Optimal renewable resources mix for distribution system energy loss minimization," *IEEE Trans. Power Syst.*, vol. 25, no. 1, pp. 360–370, Feb. 2010.
14. Rudresh B Magadam, D.B.Kulkarni, "Optimal Placement of Capacitor to Enhance the Efficiency of the Distribution Network", International Journal of Innovative Technology and Exploring Engineering, Volume-8, Issue-9, pp 2877-2881, July 2019.
15. Stephen W. Fardo Dale R. Patrick, "Electrical Power Systems Technology", Third Edition, published by Fairmont Press, Inc., Taylor and Francis group, 2008.
16. Rudresh B Magadam, D.B.Kulkarni, "Energy Loss Minimization by Optimal Siting and Sizing of DG with Network Reconfiguration in Distribution Networks", IJITEE, Volume-8, issue-10, August-2019.

AUTHORS PROFILE



Mr. Rudresh.B.Magadam was born in Sankeshwar, Karnataka, India Jul 09, 1987. He obtained his B.E and M.Tech from VTU Belagavi in 2010 and 2012 respectively. Presently he is pursuing Ph.D at KLS Gogte institute of technology, Belagavi. His area of interests includes distributed generation, micro grid, smart grid, power quality and HVDC.



Dr. D.B. Kulkarni was born in Belagavi, Karnataka, India on Feb 10, 1966. He obtained his B.E and M.E degrees from Walchand college of Engineering, Sangli, Maharashtra, India in 1986 and 1993 respectively & Ph.D in the area of Power quality from VTU, Belagavi in 2012. Currently working as professor in Electrical and Electronics Engineering department, KLS Gogte Institute of Technology, Belagavi. His areas of interest include Power quality, FACTS, HVDC transmission and Power systems.

APPENDIX

Table.5 Line data

From bus	To bus	Resistance in p.u.	Reactance in p.u.
3	9	0.0044	0.00161
3	5	0.0070	0.00091
3	26	0.0146	0.0019
3	6	0.00257	0.00113
4	15	0.00844	0.00257
4	7	0.00217	0.00095
4	8	0.00079	0.00099
4	24	0.0100	0.00636
9	25	0.0395	0.00512
9	12	0.00355	0.00046
10	13	0.00431	0.00056
10	27	0.0102	0.00133
6	14	0.0189	0.00576
7	27	0.00423	0.00154
7	16	0.0256	0.00332
17	22	0.0582	0.02430
18	23	0.0464	0.02390
24	31	0.00732	0.00095
24	32	0.0104	0.00135
28	38	0.0321	0.02930
28	33	0.0291	0.0230
29	38	0.0424	0.03870
29	34	0.0451	0.0130
30	38	0.0321	0.02930
30	35	0.0291	0.0230
40	1	0.0015	0.00296
40	2	0.0015	0.00296

Table.6 Bus data

BUS NO.	BUS kv	BUS NO.	BUS kv
1	69.0	21	0.48
2	69.0	22	0.48
3	13.8	23	0.48
4	13.8	24	13.8
5	13.8	25	13.8
6	13.8	26	13.8
7	13.8	27	13.8
8	13.8	28	0.48
9	13.8	29	0.48
10	13.8	30	0.48
11	2.40	31	13.8
12	13.8	32	13.8

13	13.8	33	0.48
14	13.8	34	0.48
15	13.8	35	0.48
16	13.8	36	2.40
17	0.48	37	0.48
18	0.48	38	0.48
19	2.40	39	4.16
20	2.40	40	69.0

25	28	0.0548	0.383	1.00	1.50
26	29	0.0548	0.383	1.00	1.50
27	30	0.0548	0.383	1.00	1.50
31	36	0.0329	0.230	1.00	2.50
32	37	0.0821	0.575	1.00	1.00

Table.7 Load data

Sl.No.	Node	Real power in MW	Reactive power in MVar
1	39	1.50	0.85
2	11	1.25	0.80
3	8	7.20	-5.40
4	17	1.20	0.75
5	18	1.20	0.75
6	19	3.20	1.90
7	20	3.20	1.90
8	21	0.60	0.40
9	22	0.12	0.07
10	23	0.12	0.07
11	33	0.25	0.15
12	34	0.10	0.05
13	35	0.25	0.15
14	36	1.80	1.20
15	37	0.85	0.50
16	38	0.50	0.25
17	28	0.77	0.47
18	29	0.93	0.57
19	30	0.77	0.47

Table.8 Transformer data

From Node	To node	R(p.u.)	X(p.u.)	Nominal Tap	MVA rating
1	3	0.0066	0.0533	1.00	15.0
2	4	0.0066	0.0533	1.00	15.0
5	39	0.0464	0.348	1.00	1.73
6	11	0.0458	0.367	1.00	1.50
12	17	0.0529	0.450	1.00	1.50
13	18	0.0529	0.450	1.00	1.50
14	19	0.0244	0.147	1.00	3.75
15	20	0.0244	0.147	1.00	3.75
16	21	0.0958	0.767	1.00	0.75

