

Implementation of Heric Transformer-Less Inverter with Multiple Sources

Arunya Revathi A

Abstract: In this paper, the implementation of HERIC transformer less inverter with variable energy sources as input is discussed. In order to get better efficiency, instead of using normal inverter transformer-less HERIC inverter had been used. The HERIC inverter contains fewer amounts of leakage current and conduction losses. Due to various climatic conditions, anyone of the energy sources (solar/wind) deliver low power. At that condition, the proposed structure is used to compensate the load requirement with the useful of battery. UP-PWM modulation is used in this proposed work. The performances were examined by using MATLAB/Simulink software. The hardware implementation of the proposed model is also discussed.

Keywords : Renewable energy, HERIC inverter, DC-DC converter, UP-PWM

I. INTRODUCTION

To reduce the pollution and global warming, the power production by replenished energy took major part in various generating methods. The energy sources like solar, wind, thermal, and tidal sources are cost effective and eco-friendly [11]. At different weather conditions, the power generation by natural sources does not provide constant electric power. Then next go for two or more energy sources to increase the power densities [5]. The load power problem is satisfied by the hybrid energy sources. In electric vehicles and hybrid loads solar, fuel cell, battery may be employed to increase the performance as well as the efficiency of the system [3]. The main aim of the system is to match the multiple source with the help of DC-DC converter.

In past decades, the power conversion system of line frequency transformers are proposed to make galvanic isolation. Afterwards these Line frequency transformers are replaced by High frequency transformers to overcome some drawbacks of LF transformers such as large, bulkiness of entire system [9].

Transformer-less inverters are used at the place of high frequency transformer, mainly for power efficiency to reduce leakage currents. In various transformer less inverters HERIC is a reliable inverter to give better efficiency [1].

II. HERIC INVERTER

A. HERIC Inverter Structure

The circuit structure of proposed novel HERIC inverter topologies is shown in fig.1. PV grid-tied systems are normally operated with the help of unity power factor.

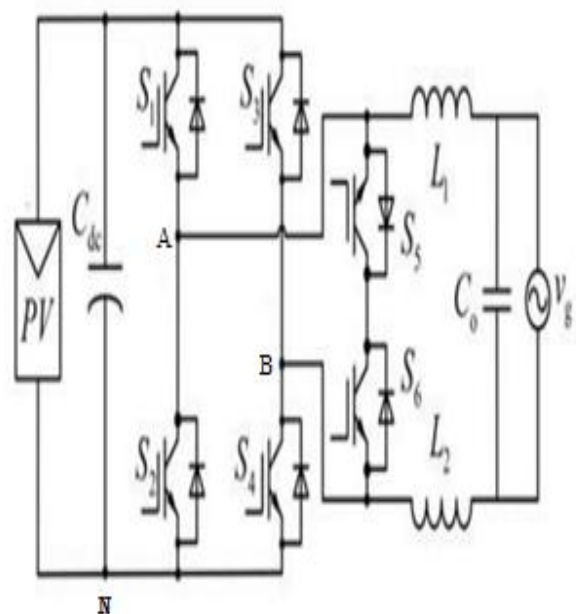

Fig. 1 HERIC Structure

B. Modes of Operation

There are four operation modes in each period of the utility grid, where V_{AN} represents the voltage between terminal (A) and terminal (N), and v_{BN} represents the voltage between terminal (B) and terminal (N). v_{AB} is the Differential-mode voltage of the topology, $v_{AB} = v_{AN} - v_{BN}$. The Common Mode voltage $v_{CM} = 0.5(v_{AN} + v_{BN})$ [13].

The conversion efficiency of the HERICs topology has very high which is 98.27% throughout the entire working state, usually the bidirectional switches are controlled with the high frequency.

Revised Manuscript Received on October 15, 2019.

Arunya Revathi A, EEE department, Alagappa Chettiar Government College of Engineering & Technology, Karaikudi, TamilNadu, India.
Email: arunyarevathi_eee@yahoo.co.in

Implementation of Heric Transformer-Less Inverter with Multiple Sources

TABLE I CONDUCTING MODES OF HERIC INVERTER

| Modes | Half Period | Conducting Devices | Voltage Range |
|--------------------|-------------|--|-------------------------------------|
| Active Mode | Positive | S ₁ ,S ₄ ,S ₅ | V _{AB} =+ V _{dc} |
| Free Wheeling Mode | Positive | S ₅ ,S ₆ | V _{AB} =0 |
| Active Mode | Negative | S ₂ ,S ₃ ,S ₆ | V _{AB} = - V _{PV} |
| Free Wheeling Mode | Negative | S ₅ ,S ₆ | V _{AB} =0 |

III. DC-DC CONVERTER

A different power sources such as solar, wind and battery are matched via DC-DC converter. Natural energy resources and storage element were used in this work. These different sources supply power individually or simultaneously. These two sources operated at unidirectional and storage element acted as bidirectional that means it will acts as source as well as load. Whenever an absence of any sources or the power production by the main sources becomes lower than the demanded power the multi-input converter satisfies the high power demands. The multiport DC-DC converter controls the power flow between the generating system and the load. All of the ports are used to make the Bidirectional energy flow. The efficiency of the converter has been calculate by the equation(1).

$$\eta = \frac{P_{dc-losses}}{P_{dc}} \quad (1)$$

Where,

P_{dc}- dc power
η- efficiency

IV. PROPOSED TOPOLOGY

In the proposed system, the DC-DC converter with multiple inputs has been used with HERIC inverter to meet the hybrid power load requirements. As shown in Fig. 2, the proposed topology has two unidirectional sources such as solar and wind and on the other hand the battery used as a bidirectional manner.

A. PV Sub System

In solar panel, the cells are getting in series connection to attain the direct current. The solar cells are designed as a current basis which is anti-parallel with diodes. DC current is generated when the solar cells are showing to the sunlight. The power production by solar energy is mostly depends upon the insolation and irradiance of the solar panel [5]. The output current can be obtained by following equation (2)

$$I_{PV} = I_s - I_{PVO} \left[\exp \left(\frac{q(V_{PV} + I_{PV} R_{sh} R_s)}{AkT} \right) - 1 \right] \quad (2)$$

Where,

I_{PV}, I_{PVO}– Cell output and cell saturation current

R_s, R_{sh}– Series and shunt resistance

Q – Electric Charge

k- Boltzmann constant

T- Cell Temperature

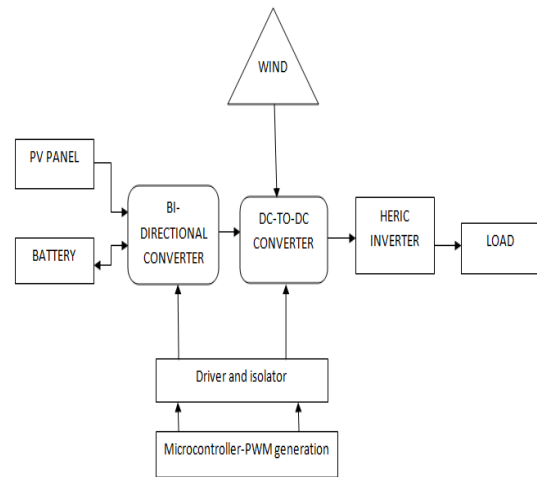

Fig. 2. Block diagram of Proposed system

B. Wind Sub System

The wind generating system is used to extract the power from wind with variable speed ratios. The maximum power output is depending upon the aerodynamic power C_p. When C_p is fixed to its maximum value maximum power will be extract from the wind energy [15]. The wind energy also depends on hub height, wind speed and pitch control. Thus, the mechanical power generated by a horizontal axis turbine can be written as equation (3).

$$P_w = 0.5 \rho A v_w^3 C_p(\lambda) \quad (3)$$

Where,

P_w-Wind power

P-Air density

A-Swept area of blades

C_p-Power coefficient

λ-Speed ratio

C. Battery

A battery is device which contains single or multiple electrochemical cells to store the energy. Anode and cathode terminal is present for supplying a power. In this proposed method, the battery used for bidirectional purpose by connecting bidirectional converter with it. The excess amount of power is stored in the battery, while output power is increased than the load power, then the stored energy is discharged to the load at the period power demand.

D. Bidirectional Converter

In hybrid generating systems, the bidirectional power flow can be obtained by using bidirectional converter. the bidirectional converter is recommended to energize and de-energize in single stage of converter. When the required amount of power is produced by any other sources, then the battery will starts to charge.

Whenever the demanded power is increased compared to the produced power, automatically the battery will discharge their energy and at that time it acts as a source through bidirectional converter. In this paper, the fly back converter operated as bidirectional converter as well as the boosting converter [6].

E. Flyback Converter

The fly back converter is similar to the usual buck-boost converter, except the transformer is added for the isolation purpose. It converts the power of DC/AC from input side to output side.

F. Modulation Technique

The modulation control is carried out by Unipolar Pulse Width Modulation (UP-PWM) control. In this paper, unipolar PWM is more recommended than bipolar PWM. Because the unipolar PWM had the advantages of better efficiency, lower THD and also it gives a pure sinusoidal output than bipolar PWM [15].

V. SIMULATION AND RESULT DISCUSSION

The efficiency and feasibility of the proposed system is analyzed through simulation. Simulation is carried out by MATLAB/Simulink software.

A. Simulation Diagram

Fig.3 shows the simulations of HERIC inverter with multiple input sources like solar, wind and battery which are fed into the multiport DC-DC converter.

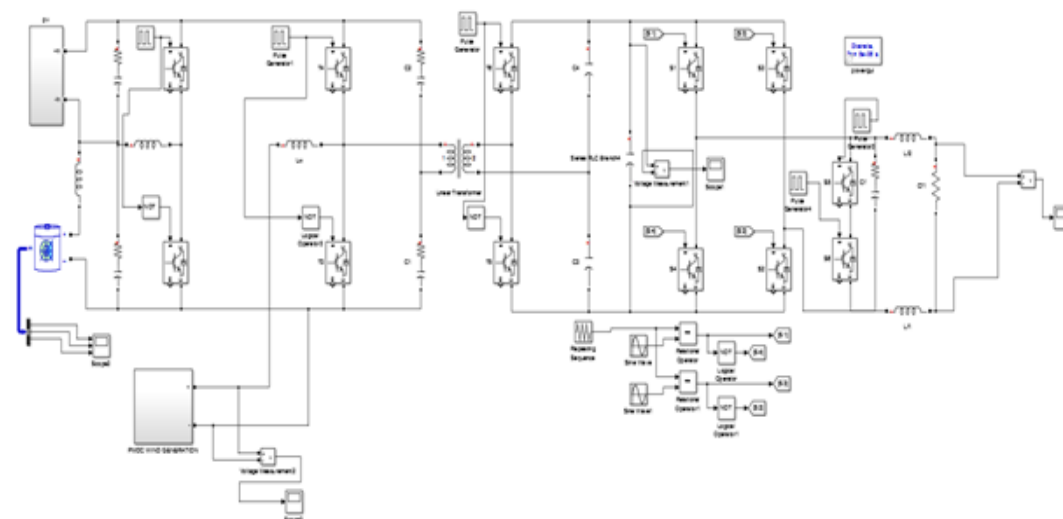

Fig. 3 Simulation of the proposed system

B. Output Waveform

The output voltage waveforms from inverter are shown in fig 4. The output voltage is nearly 80V.

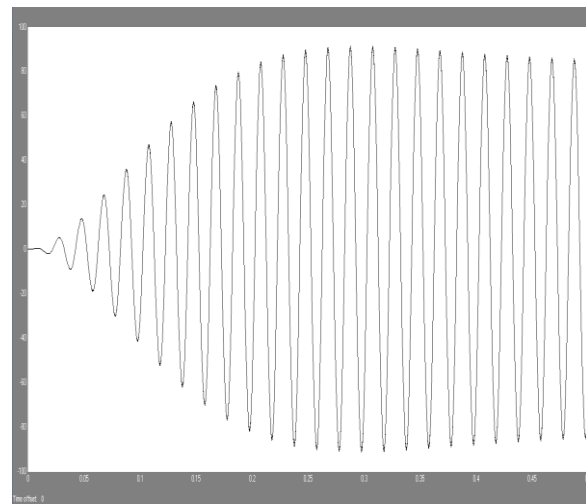

Fig. 4 Output Waveform

VI. HARDWARE IMPLEMENTATION

In order to verify the effectiveness of proposed system and hardware of the above simulations were implemented using 10W solar panel. The hardware outlook also contains the dsPIC30F2010 microcontroller, crystal oscillator. Driver circuit, isolator circuit and the pulse generation coding were implemented using mplab ide software. In order to analyze the real time performance of HERIC inverter the parameters of the system are reduced as those in simulations. In addition, the input voltage from wind turbine was provided by an AC power supply, and the output was connected to the R load. The proposed hardware outlook is shown in Fig.5.

Implementation of Heric Transformer-Less Inverter with Multiple Sources

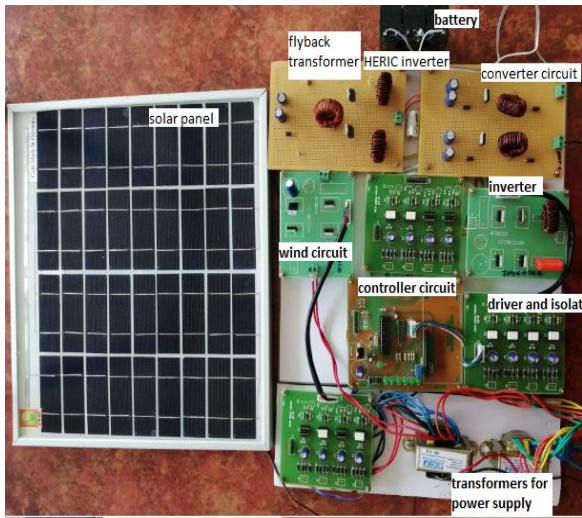

Fig. 5 Hardware Outlook

A. Output waveforms

Solar Panel: The 10W solar panel had been used for this work. The input taken from the panel at the irradiance of 740W/m² is 17.2V. When solar panel alone used the output obtained from the inverter is 38V. The output voltage is shown in Fig.6.

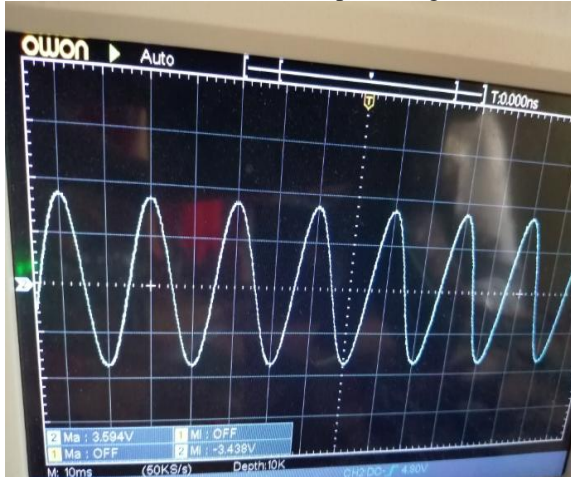

Fig. 6 Output when using Solar

Wind Source: The input from the wind source should be taken from ac circuit. The output obtained from the wind has been 35V which is shown in Fig. 7.

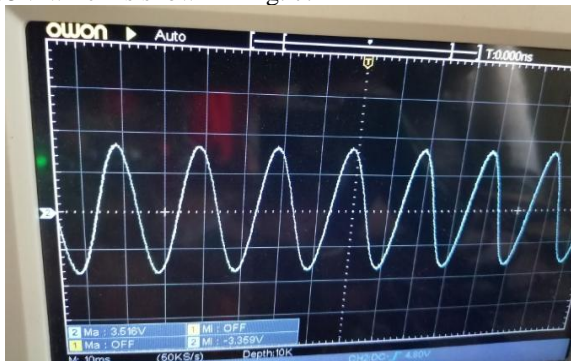

Fig. 7 Wind Output

Battery Output: The 12V battery used as source as well as load. The output of inverter when using battery only shown in Fig. 8. The battery output voltage nearly 56V.

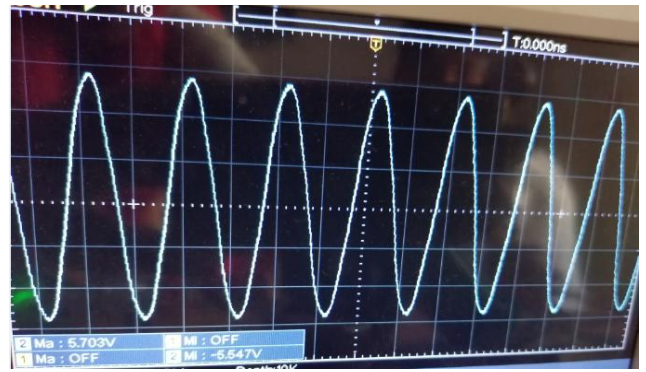

Fig. 8 Battery Output

Overall Output: The output waveform when using solar and wind is shown in Fig.9. The output voltage is nearly 58 V when using solar and wind source.

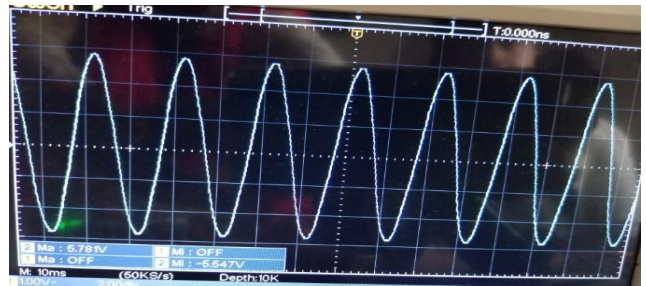

Fig. 9 Overall Output

TABLE II RESULT COMPARISON

| Parameters | Simulation | Hardware |
|---|------------|----------|
| Solar Input Voltage | 21.6V | 18.5V |
| Wind Input Voltage | 11.4V | 12V |
| Battery Voltage | 12V | 12V |
| Inverter output Voltage (Solar alone) | 40V | 35V |
| Load | 10Watts | 10Watts |
| Inverter output Voltage (Wind alone) | 50V | 34V |
| Inverter output Voltage (Battery alone) | 70 | 56V |
| Overall output (Solar & wind) | 80V | 60V |

The comparison of simulation and Hardware results are shown in table II. The resultant output from various sources are shown in above table.

VII. CONCLUSION

The high power loads are required more amount of power. A single energy source cannot achieve it. The proposed work meets the load requirement with the help of renewable energy sources. Hence lagging of output power has been overcome by hybrid energy sources. The simulation was carried out by MATLAB/Simulink. The simulations are implemented in hardware and the performance results are discussed. From the hardware, the output voltage is obtained as 58V.

REFERENCES

1. Chiragsinh M. Raj, Mr.Hitesh Lade, "An Overview Of 1-Phase Transformerless Heric Inverter Topology For Standalone System",International Journal of Advance Engineering and Research Development Volume 3, Issue 12, December -2016.
2. Farzam Nejabatkhah,Saeed Danyali, Seyed Hossein Hosseini, Mehran Sabahi,and Seyedabdolkhalegh Mozaffari Niapour, "Modeling and Control of a New Three-Input DC–DC Boost Converter for Hybrid PV/FC/Battery Power System", IEEE Transactions On Power Electronics, VOL. 27, NO. 5, MAY 2012 2309.
3. J. T. Bialasiewicz, "Renewable energy systems with photovoltaic power generators: Operation and modeling",IEEE Transactions on Industrial Electronics, vol. 55, pp. 2752–2758, July 2008.
4. Luca Solero, Alessandro Lidozzi,and Josè Antenor Pomilio,"Design of Multiple-Input Power Converter for Hybrid Vehicles" IEEE Transactions On Power Electronics, VOL.20, NO. 5, SEPTEMBER 2005.
5. M. Liserre, R. Teodorescu, and F. Blaabjerg, "Stability of photovoltaic and wind turbine grid-connected inverters for a large set of grid impedance values," IEEE Transactions on Power Electronics, vol. 21, pp. 263–272, Jan 2006.
6. Olive Ray, and Santanu Mishra, "Boost-Derived Hybrid Converter With Simultaneous DC and AC Outputs," IEEE Transactions On Industry Applications,Vol. 50, NO. 2, MARCH/APRIL 2014.
7. Rouzbeh Reza Ahrabi, Hossein Ardi, Mahdi Elmi, Ali Ajami,"A Novel Step-up Multi-Input DC-DC Converter for, Hybrid Electric Vehicles Application", IEEE Transactions On Power Electronics,2016.
8. S. Deng, Y. Sun, J. Yang, Q. Zhu, and M. Su, "Optimized hybrid modulation strategy for AC bypass transformerless single-phase photovoltaic inverters," J. Power Electron., vol. 16, no. 6, pp. 2129-2138, Nov. 2016.
9. Sudhin Roy and L.Umanand,"Integrated Magnetics-Based Multisource Quality AC Power Supply," IEEE Transactions On Industrial Electronics, VOL. 58, NO. 4, APRIL 2011.
10. Ting-Chia Ou, Whei-Min Lin, and Cong-Hui Huang,"A Multi-Input Power Converter for HybridRenewable Energy Generation System"IEEE Trans. Power Electron.,vol. 20, no. 1, pp. 236–243, Jan. 2005.
11. Tony El Tawill,Jean Frederic Charpentier, Mohamed Benbouzid, and Gang Yao, "Design,Analysis and comparison of inverter control methods for micro grid application for standalone system,"vol. 26, pp. 3075–3078,Nov 2017.
12. Xin Wang, Subbaraya Yuvarajan, and Lingling Fan, "MPPT Control for a PMSG-Based Grid-TiedWind Generation System" in Proc. 2010 IEEEApplied Power Electronics Conference and Exposition, pp. 149-154.
13. X. Guo, "A novel CH5 inverter for single-phase transformerless photovoltaic system applications", IEEE Trans. Circuits Systems II:Express Briefs, Vol. 64, no. 10, pp. 1197-1201, Oct. 2017.
14. Zhongting Tang, Mei Su, Yao Sun, "A Hybrid UP-PWM Scheme for HERIC Inverter to Improve Power Quality and Efficiency,"IEEE Transactions On Power Electronics, VOL. 1 PP, NO. 99, 2018.
15. Anuja Nambodiri,Harshal.s.Wani, "Unipolar and Bipolar PWM Inverter", International Journal for Innovative Research in Science & Technology, Volume 1, Issue 7,Dec 2014.

AUTHORS PROFILE



Arunya Revathi A received her B.E. degree in Electrical & Electronics Engineering from Madurai Kamaraj University, Madurai, India, in the year 1998, M.E. degree in Power System Engineering from Madurai Kamaraj University, Madurai, India, in the year 1999 and Ph.D., degree in Electrical Engineering from Anna University Chennai, India in 2009. She is currently working as an Associate Professor in the Department of EEE,

Alagappa Chettiar Government College of Engineering & Technology, Karaikudi, India. She has published papers in International & National journals & Conferences. Her current research interests include power system, Power Electronics, Digital Electronics, Photonic Crystals and Metamaterial. She has 20 years of teaching as well as research experience in various fields.