

Logic Control of Static Excitation System in Power Alternators using PLC



I. William Christopher, G.S. Ashwinraj, P. Jeneve Vinolia, M. Kaviya

Abstract: Logic control of Static Excitation System (SES) in Power Alternators deals with the use of PLC to control the terminal output voltage of the Alternator in a more simplified and efficient manner using a closed loop system. A closed loop control with negative feedback is designed, which involves AVR, Pulse Generator, Pulse Amplifier, Limiters, Power System Stabilizers with an Auto and a Manual channel. Disruption in the terminal voltage is caused by faults. These faults were rectified earlier by Electro Mechanical relays. Now we are at a major technological Change of Analog to Digital control. It reduces the complexity of the control system, and eliminates the need of wide range of contactors and coils to energise the relay. The best way to maintain the stability of the system is to identify the need and rectify it. This paper proposes an easy and an efficient design for fault detection and elimination using PLC based excitation system in power alternators.

Index Terms: Static Excitation Systems (SES), Static Excitation Equipment (SEE), Power Alternators, Programmable Logic Controller (PLC), Faults

I. INTRODUCTION

The existing system for control of excitation system consists of large number of contactors and coils for simple operation. Relay is only used as switch which is used to control high voltage device using low voltage signal and relay cannot be programmed. While PLC is Programmable Logic Controller having counter, timer, Input/Output, which can be programmed according to user requirement and hence interfaced device is controlled accordingly [1]. The advantages of PLC over electro mechanical relays are ability to interface / communicate with computers, simple programming, high reliability, easy maintenance, rugged construction, operate in extremely harsh conditions, small size and easy expandability.

II. STATIC EXCITATION SYSTEM

Static excitation system is a direct type of excitation system, where a thyristor panel which primarily uses SCR's does the rectification. The voltage from the alternator output is stepped down and fed to the excitation transformer. In the excitation transformer the voltage is further stepped down from 3.3KV to 380 V. This voltage is supplied to the SCR bridge. During initial startup of the alternator voltage to the excitation transformer is supplied from battery backup [2-3].

The output from the SCR is controlled by the firing angle applied to the gate of the SCR. This firing angle is determined by various components in the control unit of static excitation system. There are two channels one auto channel and one manual channel (50 MW alternators) which form a negative feedback system and determine the firing angle respectively.

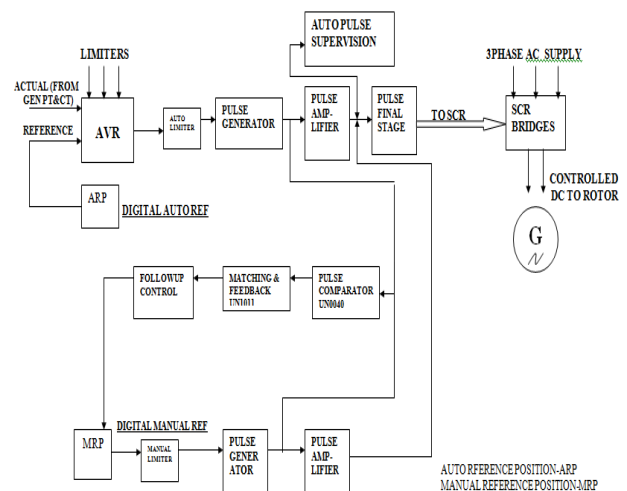

Fig. 1. SEE Block Diagram

The block diagram of Static Excitation Equipment (SEE) is shown in figure.1. It consists of the various equipment installed to control the excitation system of an alternator. The main principle components in the system are Automatic Voltage Regulator (AVR), Pulse Generator, Pulse amplifier, Pulse final stage amplifier, Thyristor panel, its cooling system, Potential Transformer (PT), Current Transformer (CT) and the excitation transformer [4]. The main aim of our project is to identify the possible faults and its rectification, so as to prevent the instability in the system. The output voltage from alternator is metered by potential transformer and current transformer and the reading is fed to AVR. This signal acts as the actual signal which is compared with the reference signal set by the unit control board.

Revised Manuscript Received on October 30, 2019.

* Correspondence Author

Dr. I. William Christopher*, Associate Professor, EEE Department, Loyola-ICAM College of Engineering and Technology (LICET), Anna University, Chennai, India, E-mail: iwchristop@gmail.com

G.S. Ashwinraj, Faculty of Information and Communication, College of Engineering Guindy, Anna University, Chennai, India.

P. Jeneve Vinolia, Management Studies, Loyola Institute of Business Administration, (LIBA), Chennai, India.

M. Kaviya, Cortex Consulting Private Limited, Chennai, India.

© The Authors. Published by Blue Eyes Intelligence Engineering and Sciences Publication (BEIESP). This is an open access article under the CC BY-NC-ND license (<http://creativecommons.org/licenses/by-nc-nd/4.0/>)

The two signals are compared by the AVR which also receives signals from various other limiters and power system stabilizers [5]. The power system stabilizers are used to prevent power swing in alternators i.e to suppress oscillation (pole slip). The difference between the highly stabilized reference and the actual value is amplified in different stages of amplification. Three Current Transformers senses the output current of the Alternator, feed proportional current across variable resistors in the AVR [6]. The voltage thus obtained across the resistors, can be added vectorially either for compounding or for transformer drop compensation. The output of the AVR is fed to a pulse generator. The pulse position varies continuously as a function of the control voltage. Two relays are provided and by energizing them the pulses can be either blocked completely or shifted to inverter mode. The pulse output of the "pulse generator" is amplified further at intermediate stage amplification. This is also known as pulse intermediate stage [7-8]. The Auto and Manual channel changeover is affected by energizing/de-energizing the relay. This unit receives input pulses from the pulse amplifier and transmits them through pulse transformers to the gates of the thyristors. A built in power supply provides the required dc supply to the final pulse and amplifier. Each Thyristor bridge has its own final pulse stage. Therefore, even if one Thyristor bridge fails with its final pulse stage, the remaining thyristor bridges can continue to cater to full load requirement of the machine and thereby ensure (n-1) operation. A separate manual control channel is provided where the d.c. control signal is taken from a stabilized d.c. voltage. The d.c. signal is fed to a separate pulse generator whose output pulses after being amplified at an intermediate stage can be fed to the final pulse stage. When one channel is working and generating the required pulses, the other remains blocked. Therefore, a changeover from "Auto" to "Manual" control or vice-versa is affected by blocking or releasing the pulses of the corresponding intermediate stage. To ensure a smooth changeover from 'Auto' to 'Manual' control, it is necessary that the position of the pulses on both channels should be identical. A pulse comparison unit detects any difference in the position of the pulses.

III. LADDER DIAGRAM

Ladder diagrams are specialized schematics commonly used to document industrial control logic systems. They are called "ladder" diagrams because they resemble a ladder, with two vertical rails (supply power) and as many "rungs" (horizontal lines) as there are control circuits to represent. The following figures from figure.2 to figure.10 shows that the ladder diagram (program) related to various rung numbers with different operations.

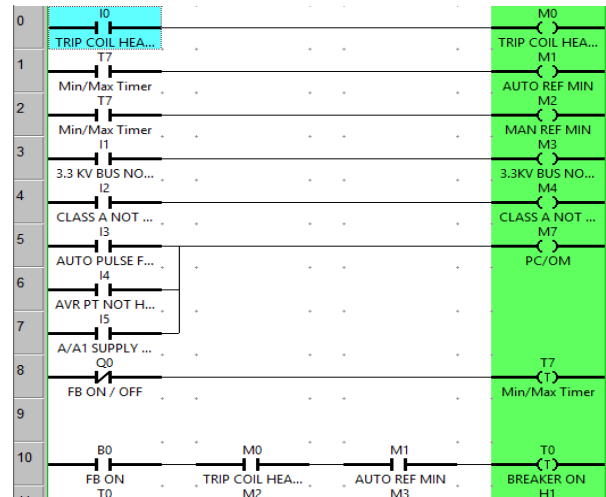

Fig. 2. Rung 0 to 10

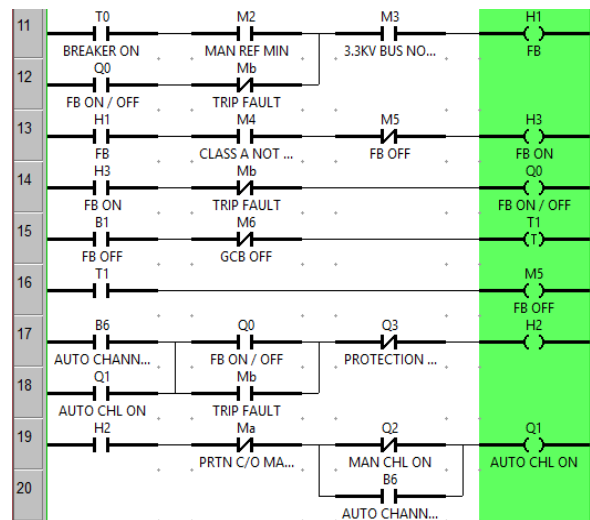

Fig.3. Rung 11 to 20

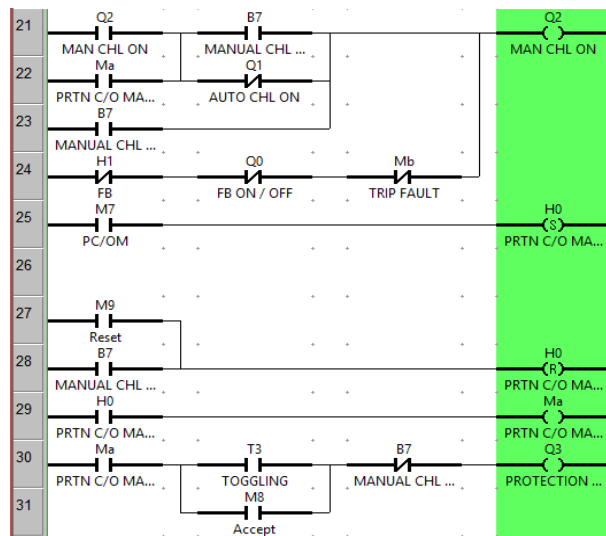

Fig.4 Rung 21 to 31



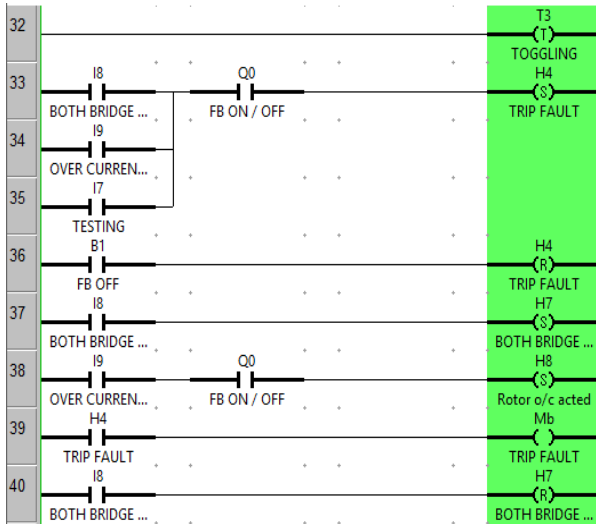

Fig.5 Rung 32 to 40

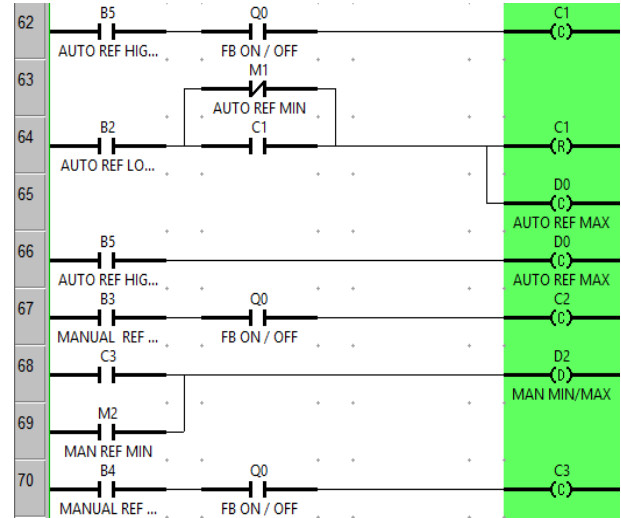

Fig.8. Rung 62 to 70

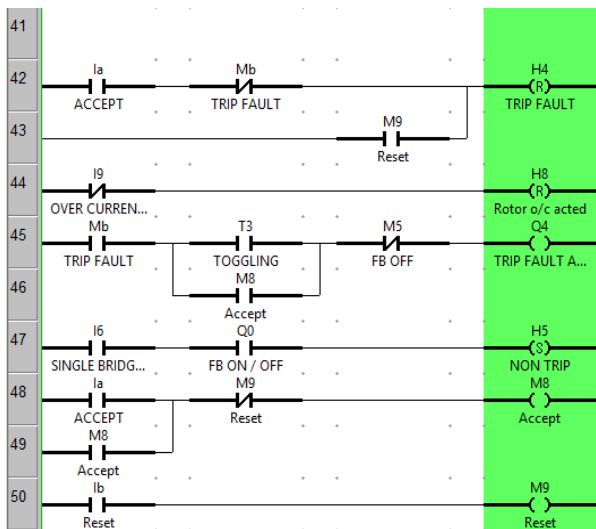

Fig.6. Rung 42 to 50

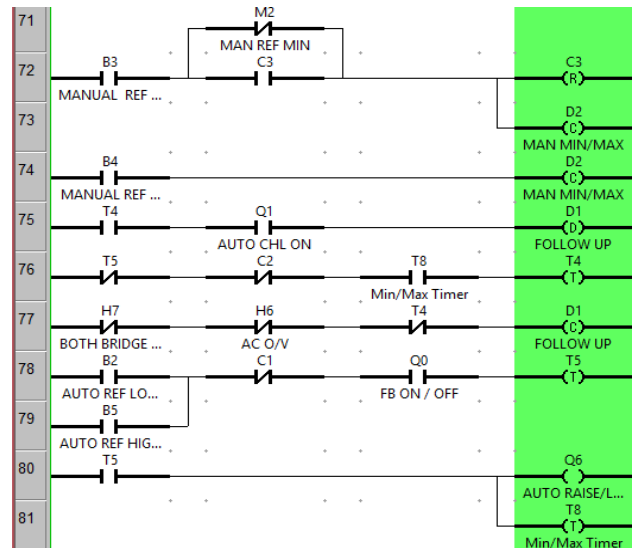

Fig.9. Rung 71 to 80

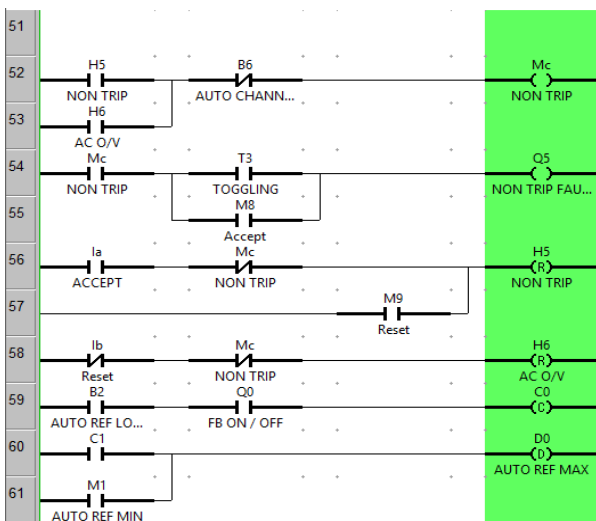

Fig.7. Rung 51 to 61

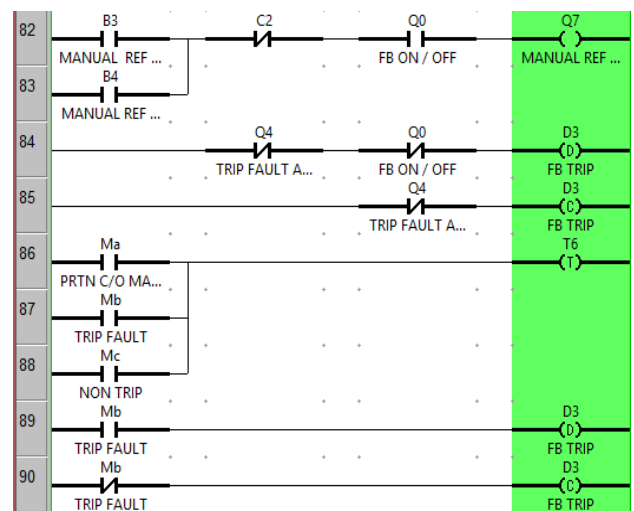

Fig.10. Rung 82 to 90

IV. SIMULATION RESULTS AND DISCUSSIONS

The ZEN support software was used for designing the logical algorithms and to view the simulation results. Design process began with the identification of the inputs and the required output indications. The algorithms were implemented in the rungs using ladder diagram. The contactors were fixed as either NO (normally open) or NC (normally close) and many Internal relays, hold relays, Timers, Counters and Display operation were implemented in the ladder diagram and setting of parameters for the contactors and coils were also done. The Figure.11 is the execution simulator for the program which was developed in the ladder diagram shown in the previous section. In this figure I0, I1, I2, I3, I4, I5, I6, I7, I8 and I9 are the inputs and Q0, Q1, Q2, Q3, Q4, Q5, Q6, Q7 are the outputs.

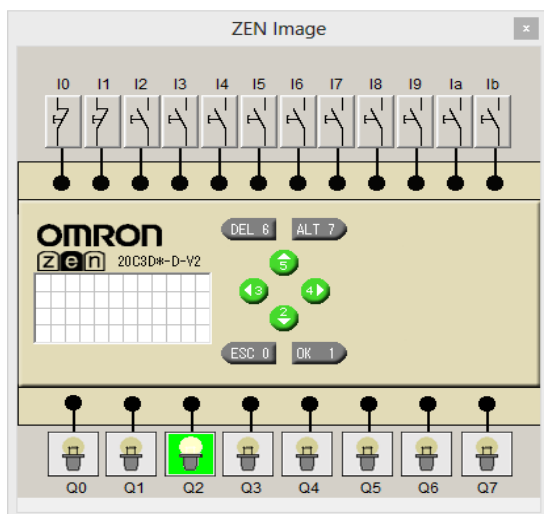

Fig.11. Basic Simulation

The assigned input functions are shown in table .1

Table.1. Inputs and Assigned functions

S.No.	Inputs	Assigned function
1	I0	Trip Coil Healthy
2	I1	3.3kvbus Voltage Normal
3	I2	Class A Not Acted
4	I3	Auto Pulse Fail
5	I4	AVR PT Not Healthy
6	I5	A/A1 Supply Fail
7	I6	Single Bridge Fail
8	I7	AVR Under Testing
9	I8	Both Bridge Fail
10	I9	Over Current Acted

Ia is accent and Ib is reset. B0, B1, B2, B3, B4, B5, B6, B7 are buttons which are also considered as inputs and they act as commands. Some of the input conditions are considered as faults and those faults are identified and separated as trip fault, non-trip fault and protection change over to manual. The assigned output functions are shown in table .2

Table.2. Outputs and Assigned functions

S.No.	Outputs	Assigned function
1	Q0	Field Breaker in closed condition
2	Q1	Auto channel ON
3	Q2	Manual channel ON
4	Q3	Protection Change Over To Manual

5	Q4	Trip Fault Acted
6	Q5	Non Trip Fault Acted
7	Q6	Auto Raise/Lower
8	Q7	Manual Raise/Lower.

When the simulator has started to execute the program, at initial stage I0 and I1 should be closed; as they sssform the basic requirements for the field breaker to close. It also requires auto reference and manual reference value to be in minimum for the field breaker to be closed.

A. Field Breaker ON

The Figure 5.13 shows that the field breaker is closed by Q0 indication only after ‘field breaker is on’ command (B0) is

given. The display shows that the auto reference and manual reference value is minimum.

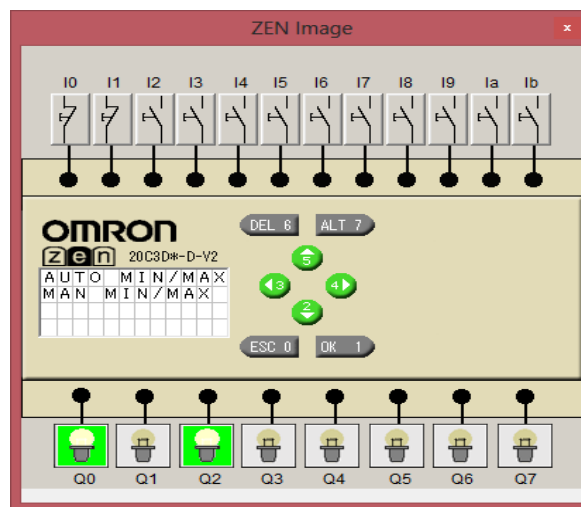

Fig.12. Field Breaker ON condition

B. Auto Channel ON

The Figure 13 indicates ‘Auto pulse on’ command and is given by B6 so that Q1 glows which indicate that the auto channel is on.

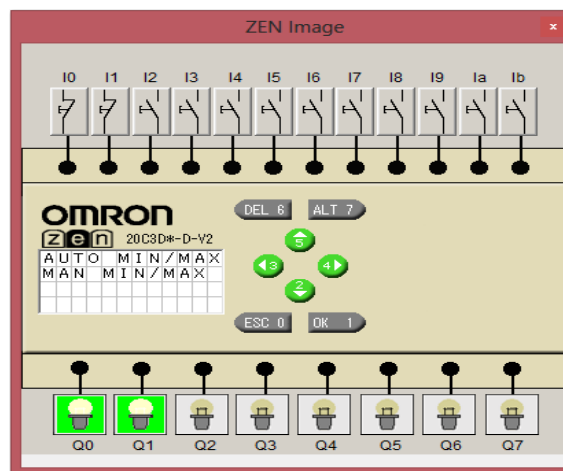

Fig.13. Field Breaker ON condition

C. Protection Change Over to Manual

In Figure 5.15 it can be seen that I3 is closed which shows that auto pulse fails. Automatically Q1 starts glowing and Q2 starts glowing indicating that the manual channel is on and also Q3 starts blinking indicating the protection is changing over to manual. When Ia is closed Q3 stops blinking and starts glowing. After rectifying the fault i.e., I3 in open contact, Ib is closed so that Q3 stops glowing indicating that the fault has been rectified and by pressing B6 the channel is changed to auto channel.

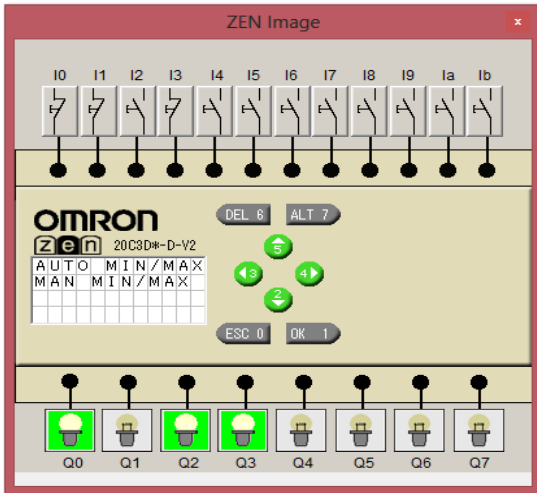

Fig.14. Protection Change Over to Manual

D. Non Trip Fault

In the Figure 5.16, I6 is closed which shows that single bridge in SCR fails, then Q5 starts glowing indicating that a non-trip fault has occurred.

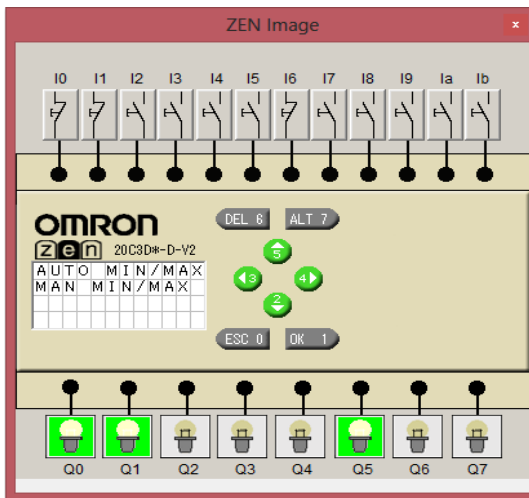

Fig.15 Non Trip Fault

E. Trip Fault

In the Figure 5.17, I9 is closed which shows that over current has acted.

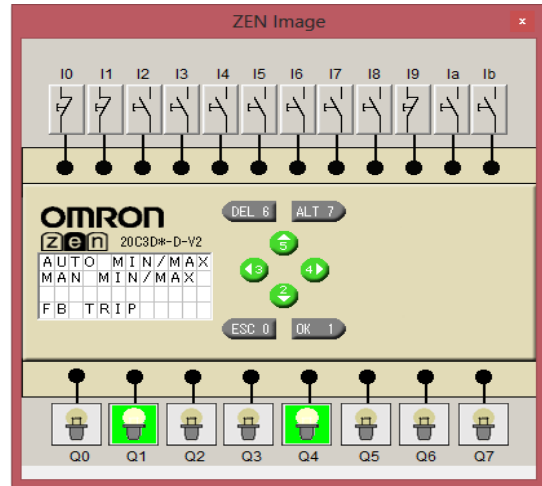

Fig.16 Trip Fault

Immediately Q0 stops glowing indicating that field breaker is open because it is a trip fault and also Q4 starts glowing which also indicates that a trip fault has occurred. The LCD display also shows that field breaker is tripped.

V. EXPERIMENTAL VALIDATION

The ZEN model PLC has 12 inputs and 6 outputs. A positive 12 voltage supply is given to the power terminals. The inputs are also given +12 V supply, if the input is made ON it is indicated by the LED. Similarly, the output is indicated by LED.

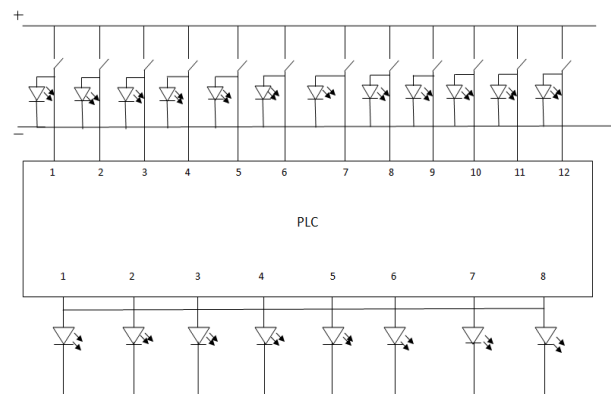

Fig.17. Hardware circuit connection

The hardware component specifications of the proposed system are given in the table 3.

Table.3. Hardware Component Specifications

S.No.	Component	Specification
1	OMRON ZEN Model PLC	<ul style="list-style-type: none"> 96 Lines of Program Capacity 44 Max. No. of control I/O points Cyclic scan 150 Hz Counting Speed 12V-24V Power Supply
2	Power Supply	230V

3	Transformer	230V/(12-0-12)V
4	Diode	1N4007
5	Capacitor	1000uF,470uF,0.1uF
6	Regulator	LM7812,LM7824

The OMRON ZEN model PLC and its power supply circuits are shown in figure 18 and figure 19 respectively.



Fig.18. OMRON ZEN Model PLC

A. Diode (1N4007)

A rectifier diode is used as a one-way check valve. Since these diodes only allow electrical current to flow in one direction, they are used to convert AC power into DC power. A 1N4007 diode is electrically compatible with other rectifier diodes, and can be used as a replacement for any diode in the 1N400x family.

B. Transformer

In this circuit 230V/12-0-12V centre tapped transformer is used.12-0-12 is just two 12V windings joined together at one end, it can also be a single 24V winding with a connection in the middle. It has many uses but the primary one is in low voltage power supplies where full wave rectification can be achieved with two rectifiers instead of the four needed in a bridge circuit.

C. Voltage Regulators

LM 7612- 7612 is a 12V Voltage Regulator that restricts the voltage output to 12V and draws 12V regulated power supply. The 7612 is the most common, as its regulated 12-volt supply provides a convenient power source for most TTL components. LM 7624 - 7624 is a 24V Voltage Regulator that restricts the voltage output to 24V and draws 24V regulated power supply.

D. Capacitors

Capacitors are used for filtering the rectified output and also to boost the voltage rectified. We use three types of capacitors, 0.1 micro F, 1000 micro F, 470 micro F. Each rating capacitor can withstand up to the output voltage



Fig.19. Power Supply Circuit

E. Experimental Results

When the PLC is ONed, initially Q2 indication is shown. This is to indicate that the Q2 (manual channel) is on at initial condition. The types of faults with switch indication can be easily understood by the following table 4.

Table.4. Types of faults with Switch indication.

S.No	Inputs	Type of Faults	Fault Name	Indication	
1	I3	Protection Change Over To Manual	Auto Pulse Fail	Q2 On	Q3 Blinking
2	I4		AVR PT Not Healthy	Q2 On	Q3 Blinking
3	I5		A/A1 Supply Fail	Q2 On	Q3 Blinking
4	I6	Non Trip	Single Bridge Fail	Q2 On	Q5 Blinking
5	I7	Trip	AVR Under Test Mode	Q1 On	Q4 Blinking
6	I8		Both Bridge Fail	Q1 On	Q4 Blinking
7	I9		Over Current Acted	Q1 On	Q4 Blinking

The types of faults with the corresponding condition for switch indication are illustrated in the following figures. The initial condition of the PLC based system is shown in figure 20.

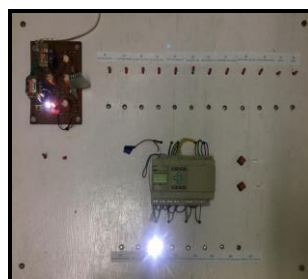

Fig.20. Initial Condition

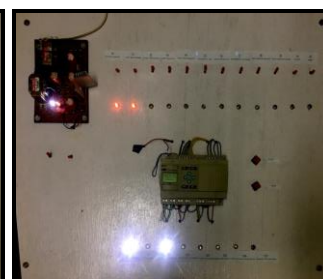

Fig.21. Field Breaker ON

When B0 command is given, Field Breaker (FB) is closed and the indication is given by Q0 is shown in figure 21. When B6 command is given, Q1 starts glowing indicating that auto channel is on is shown in figure 22.

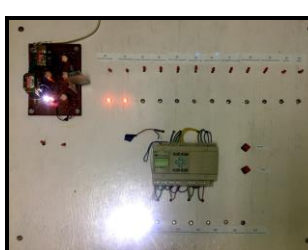

Fig.22. Auto channel ON

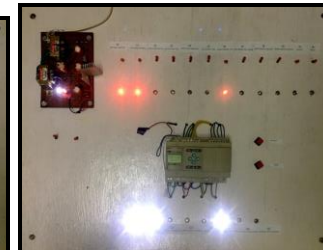

Fig.23. Protection change over to manual

When I3 input signal is received, a fault occurs, which is of protection change over to manual type. Thus an indication Q3 starts blinking, Q1 starts glowing. When an accept signal is given Q3 glows steadily and once the fault is rectified reset is given is shown in figure.23.

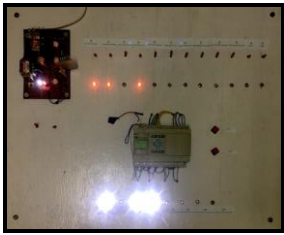

Fig.24. Non trip faults

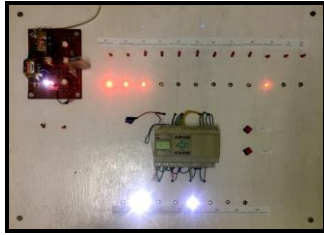

Fig.25. Trip faults

Similarly, the I6 input is given, Q5 indication starts blinking for non-trip faults are shown in figure 24. The I9 input starts the blinking of Q4 indication for trip faults are shown in figure 25.

VI. CONCLUSIONS

Thus a novel idea to reduce the complexity of large number of relays and their contactors using the above discussed logic control of Static excitation system for power alternators using PLC has been implemented successfully. The added advantages of this method of logic control are less cost and high performance. PLC's are marvelous inventions and with their non-volatile memory they perform with high efficiency and they require less maintenance. The proposed system is highly efficient in operation and maintenance when compared to the present day system. It can also be implemented as the controlling technology for the entire power plant for various sections like

1. H2 cooling system
2. Conveyor protection system
3. Seal oil leak prevention system

The implemented product is only a prototype, as the inputs to our ZEN model OMRON PLC is constrained only to 12 numbers and the output as well to 8. So, only the most important inputs are selected for demonstration. If three more PLC with 20 Inputs and outputs are provided, the entire power system can be upgraded to a PLC controlled system. PLC controlling can also be used to control all the other systems which need high event monitoring.

ACKNOWLEDGMENT

The authors wish to thank Neyveli Lignite Corporation (NLC) India Ltd a 'Navratna' - A Government of India Enterprise for providing an opportunity to carry out industrial project in their power plant. The technical supervision offered by Mr.R.Pazhaivelan, ACM/Elec/SEE & UCB Controls, Thermal Power Station-I (TPS-I), NLC was of great help in fulfilling the project work. Also the authors wish to thank the Management, Principal and the Department of Electrical and Electronics Engineering of Loyola-ICAM College of Engineering and Technology (LICET), Chennai, for their whole hearted support and encouragement for the successful completion of the project.

REFERENCES

1. Schaefer.RC, Kiyong Kim, "Excitation control of the synchronous generator", IEEE Industry Applications Magazine ,vol:7, issue:2, pp. 37-43, March/April 2001.
2. Zhu Chen, Chengxiong Mao, Dan Wang, Jiming Lu, Yuhao Zhou, "Design and Implementation of Voltage Source Converter Excitation System to Improve Power System Stability", IEEE Transactions on Industry Applications, vol:52, issue:4, pp. 2778-2788, July-August 2016,
3. Godhwani.A, Basler.MJ, Eberly.T.W, "Commissioning and operational experience with a modern digital excitation system", IEEE Trans. Energy Conversion, vol. 13, pp. 183-187, June 1998.
4. Godhwani.A, Basler MJ , "A digital excitation control system for use on brushless excited synchronous generator", IEEE Transaction on Energy Conversion, vol:11, issue:3, pp.616-620, September 1996.
5. IEEE Guide for Identification Testing and Evaluation of the Dynamic Performance of Excitation Control Systems, 1990.
6. Aguero.JL, Arnera.PL, Bianchi Lastra.RE and Beroqui.MC, "Synchronous Compensators: Models Verified by Tests of Automatic Voltage Regulator, Reactive Power Control, and Voltage Joint Control", IEEE Transactions on Power Systems, vol: 21, issue: 4, pp. 1798-1807, November 2006.
7. Brandt.D, Wachal.R, Valiquette.R,Wierckx.R, "Closed loop testing of a joint VAR controller using a digital real-time simulator", IEEE Transactions on Power Systems, vol. 6, no. 3, pp. 1140-1146, August. 1991.
8. IEEE Power Engineering Society, "IEEE Recommended Practice for Excitation System Models for Power System Models for Power System Stability Studies", 421.5-2016, IEEE Inc., 21 April 2006.

AUTHORS PROFILE



Dr.I.William Christopher received his AMIE degree in Electronics and Communication Engineering from The Institution of Engineers (India), Kolkata in 2001, M.E degree in Power Electronics and Drives Engineering from Anna University, Chennai in 2005 and PhD from Faculty of Electrical Engineering, College of Engineering Guindy, Anna University, Chennai in 2014. He is currently working as an Associate

Professor in the Department of Electrical and Electronics Engineering, Loyola-ICAM College of Engineering & Technology (LICET), Chennai and he has teaching experience of about 14 years. He has wide knowledge in Power Electronic Converters for Renewable Energy Systems, Embedded control of Electric drives and automation. He is a recipient of IET (UK) YPS Young Teacher Award from IET(UK) Chennai Network for his contribution towards the profession and IET. He has published around 16 research papers in reputed International journals and presented around 29 papers in IEEE and various International/National conferences. He is a member of various Professional societies like IE(India), IETE, ISTE and IAENG. He is currently guiding two PhD research scholars under Anna University.



G.S.Ashwinraj received his BE degree in Electrical and Electronics Engineering from Loyola-ICAM College of Engineering & Technology (LICET), Anna University, Chennai in 2018. Now he is pursuing post graduate in Master of Technology in Laser and Electro Optical Engineering in Faculty of Information and Communication, College of Engineering Guindy, Anna University, Chennai. His research areas are control of

power converters and electrical drives and applications in the field of Laser and Electro Optical Engineering.



P.Jeneve Vinolia received her BE degree in Electrical and Electronics Engineering from Loyola-ICAM College of Engineering & Technology (LICET), Anna University, Chennai in 2018. She has worked for one year in Bosch Electrical Drives Pvt Ltd, Chennai. Now she is pursuing her Post Graduate Diploma in Management (PGDM) in Loyola Institute of Business Administration, (LIBA), Chennai. Her research areas are control of power converters and electrical drives.



M.Kaviya received her BE degree in Electrical and Electronics Engineering from Loyola-ICAM College of Engineering & Technology (LICET), Anna University, Chennai in 2018. She is currently working as a recruiter in Cortex Consulting Private Limited, Chennai. Her research areas are control of power converters and electrical drives, robotics and automation.