

# Prototype for Monitoring and Accessing Electricity Usage Details in Cloud using IoT Energy Meter



Jaichandran R, Rajaprakash S, Shunmuganathan K.L, Usha Kiruthika, Muthuselvan S

**Abstract:** In this paper we presented a prototype for storing and accessing electricity usage details in cloud using IoT energy meter. Proposed system used energy meter with microcontroller to monitor electricity usage and transmits energy consumed details and cost to server. Users check hourly or daily usage of electricity and their cost online using simple web application. Prototype is experimented to check the electricity consumption details of a class room for five days. Based on Tamil Nadu government electricity board tariff rate for private educational institutions, seven rupees fifty paise is set as per unit cost for energy used. Results show proposed prototype is effective in monitoring, storing, and accessing electricity usage details in cloud. Energy consumed details and their cost is frequently updated to server and user can access their hourly or daily electricity usage details along with cost in cloud. Proposed system reduces human intervention in monitoring energy meter readings and can save significant amounts of time and money.

**Keywords:** Cloud storage, energy meter; internet of thing, sensors.

## I. INTRODUCTION

Monitoring, storing and accessing daily or monthly electricity usage details using manual method is a time consuming task and need lot of efforts since you need to go to energy meter to note down the reading [1-2]. In this paper we

have proposed an energy meter using Internet of Things (IoT). The system has capabilities like remote monitoring, storing, and accessing energy consumed details which provide complete monthly consumption report in different format such as bar chart, pie chart etc, [3-4]. The system allow consumer to view pulse by pulse per rate unit consumed and its cost. It helps electricity board to save time since they need not to go every individuals house to take down the readings and go back to the office and update to their database physically [5-6]. And being a consumer it's a tough or tedious task to keeping track on consumption since they need to go to reading room and take a note of the reading and calculate as per unit charge. Therefore automation system allowing user to monitor energy meter over the internet [7-10]. The prototype is developed using energy meter with ATmega 328 Microcontroller as front end and IOT Gecko as back end cloud. Arduino IDE is used for coding the microcontroller with C programming. Keypads are used for user interface for setting per unit cost for the energy consumed. IoT Gecko is used as the database for storing and retrieving data. The energy consumption details can be transmitted more frequently to a remote station. The implication of being able to transmit readings more often are that energy utilities will be able to generate timely bills, better understand energy demand patterns and helps in identifying energy meter failures. Graphs and bar charts in IoT Gecko are used to visualize and analyze energy consumption details and their cost. The entire system can be cost effective and significant amounts of time and money can be saved, by implementing automated system, as opposed to one involving the human element. The system also poses much less of a safety risk since human interaction has been minimized..

## II. LITERATURE STUDY

Ashna, K., and George, S.N proposed automated energy meter. Noting down energy meter reading by a human is time consuming activity and inefficient to meet growing residential population. So demand for automated energy meter increased and its application is expanded over industrial, commercial and utility environment. Electronic utility meter play important role in the development of automated energy meter. It has many features to reduce consumers utility cost and cost of delivering utilities to utility provider.

Revised Manuscript Received on October 30, 2019.

\* Correspondence Author

**Jaichandran R.** Department of CSE, Aarupadai Veedu Institute of Technology, Vinayaka Mission's Research Foundation (Deemed to be University), Rajiv Gandhi Salai, Old Mamallapuram Road, Paiyanoor 603104, Kanchipuram (DT), Tamil Nadu, India,

**Rajaprakash,** Department of CSE, Aarupadai Veedu Institute of Technology, Vinayaka Mission's Research Foundation (Deemed to be University), Rajiv Gandhi Salai, Old Mamallapuram Road, Paiyanoor 603104, Kanchipuram (DT), Tamil Nadu, India.

**Shunmuganathan K.L.**, principal, Aarupadai Veedu Institute of Technology, Vinayaka Mission's Research Foundation (Deemed to be University), Rajiv Gandhi Salai, Old Mamallapuram Road, Paiyanoor 603104, Kanchipuram (DT), Tamil Nadu, India,

**Usha Kiruthika,** SRM Institute of Science and Technology, Kattankulathur Campus, Chennai., Tamil Nadu, India.

**Muthuselvan S.** Department of CSE, Aarupadai Veedu Institute of Technology, Vinayaka Mission's Research Foundation (Deemed to be University), Rajiv Gandhi Salai, Old Mamallapuram Road, Paiyanoor 603104, Kanchipuram (DT), Tamil Nadu, India.

© The Authors. Published by Blue Eyes Intelligence Engineering and Sciences Publication (BEIESP). This is an [open access](http://creativecommons.org/licenses/by-nc-nd/4.0/) article under the CC BY-NC-ND license (<http://creativecommons.org/licenses/by-nc-nd/4.0/>)

# Prototype for Monitoring and Accessing Electricity Usage Details in Cloud using IoT Energy Meter

Onset of rural electrification provides opportunities for new and more efficient metering technologies. According to Tom Hargraves, Michael Nye, and Jacquelin Burgess the Qualitative field householders of UK interacted on their domestic energy consumption in a field trail of real time display or energy monitors. This monitoring system help consumers with real time information on their electricity usage help them to control consumption, to save money and reduces emission. As they explained the very first attempt to explore qualitative how United kingdom householders interact with real time display. Social and cultural practices of households and their associated energy use are influenced by a number of factors which may have no direct connection with either energy or the environment. Darshan Iyer, N., and Radha Krishna Rao, K. A., con-ducted research to address growing energy needs and some measures need to be taken. Authors designed a device with in-built capability to measure and report energy consumed to server. Prototype creates energy used awareness to users. Sensor measures current flow in energy meter then microcontroller calculates energy used details and cost in server using internet. By monitoring energy consumption regularly, we can analyze pattern for energy usage and make better decisions in controlling current wastage using Internet of Things [5-7]. Authors presented internet connected energy meter and controlling system that increases energy consumption awareness among users. Energy usage awareness enables users in controlling power state of devices as per needs which intern minimizes energy consumption. In IoT each devices have their own identity using IP address and shares information to other devices or server through network [9-10].

### III. SYSTEM DESIGN

Figure 1 illustrates design of proposed system. The primary components in the system are described as follows.

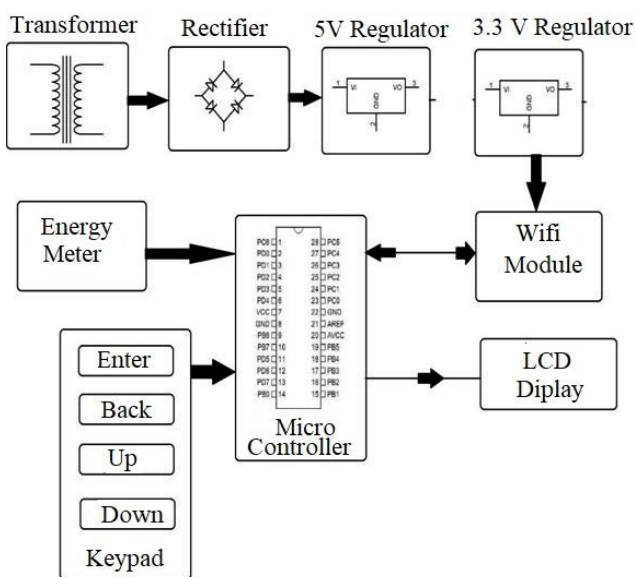

Fig. 1 System Design

#### Transformer

It converts AC electricity from one voltage to another with

loss of power, and step down transformer to reduce high voltage to low voltage. Many place use step-down transformer it is reduce high voltage to low voltage. Middle of the circuit is called core. Input coil is connected with high voltage and give low output voltage.

**Rectifier:** It is an electrical devices and it is converts alternating current (AC), and time to time it will go reverse direction to direct current (DC), it flow only one direction, that process is known as rectification.

**Regulator:** Three positive Regulators are available in LM78XX/LM78XXA series. There employs current limiting, and thermal closed and good operating conservancy. That device we use only external components and adjust voltage and current.

**Energy Meter:** It is a device and it is measure amount of electrical energy applied by a residence. It is a billing unit. There shows periodic reading of electric meter set to billing cycle's energy use during a cycle. In some area electric charge is high during specific time; also in some area people understand needless equipment.

**Wifi Module:** The ESP8266 is a low-cost Wi-Fi chip produced by Espressif Systems, Shanghai based Chinese manufacturer. This small module allows microcontrollers to connect to a Wi-Fi network and make simple TCP/IP connections using Hayes-style commands.

**LCD Display:** In LCD display there we so the command whatever we given in the manually. If we give the option that up option down option it is show in LCD. It is operate with 4-bit data bus and 8-bit data bus. Control line gives the command that what data send to LCD.

**Microcontroller:** The Atmel ATmega328P is a 32K 8-bit microcontroller based on the AVR architecture. Many instructions are executed in a single clock cycle providing a throughput of almost 20 MIPS at 20MHz. The ATMEGA328-PU comes in an PDIP 28 pin package and is suitable for use on our 28 pin AVR Development Board. The ATmega328 chip features includes timers, PWM pins, interrupts, sleep modes, analog and digital pins. These pins allow to connect external hardware to your Arduino. These pins are key for extending the computing capability of the Arduino into the real world. Simply plug your devices and sensors into the sockets that correspond to each of these pins and you are good to go.

**Keypad:** Keypad has 4 buttons for Enter, back, up and down. When enter button is pressed the system shows two options: display and setting. If display option is pressed then energy consumed details and its cost are display. When setting option is pressed, unit cost for the energy consumed can be set. The up and down buttons are used in selecting the options and unit cost can be increased using up button and decreased using down button.

### IV. IMPLEMENTATION

Figure 2 illustrates Implementation of the prototype and the primary components in the prototype include: energy meter, board with wifi wireless connectivity, and LCD keypad. Figure 3 illustrates the work flow diagram of the prototype.

One end of energy meter is connected with 230v AC input and other end with load. Microcontroller is connected with energy meter to access energy units consumed. Keypad buttons are used in selecting options and fixing unit cost. The microcontroller is connected with the energy meter and user or customer must have wifi or internet connection for frequent updates. Energy consumption details and their cost will be sent periodically to the server.

**V. EXPERIMENTS AND RESULTS**

Prototype is experimented in a class room for 5 days from Monday to Friday. Class room contains four 40 watts tube light and 70 watts ceiling fans. Working hours of class room is from morning 9 am to evening 4 pm Lunch time is between 12 pm to 1 pm. Last hour of fifth day in a week is allotted as library hour. The four tube lights and four ceiling fans are operated during working hours and switched off during lunch time, and library hours. The energy consumption details are measured in units. For example 1 unit of energy will be consumed if 1000 watts light used for 1 hour. In the class rooms there are four 40 watts tube lights and four 70 watts ceiling fans are used. The energy consumed by the class room in 440 watts in one hour. Therefore energy consumed by the class in one hour will be 0.440 units. We have fixed Rs. 7.50 as per unit energy cost.

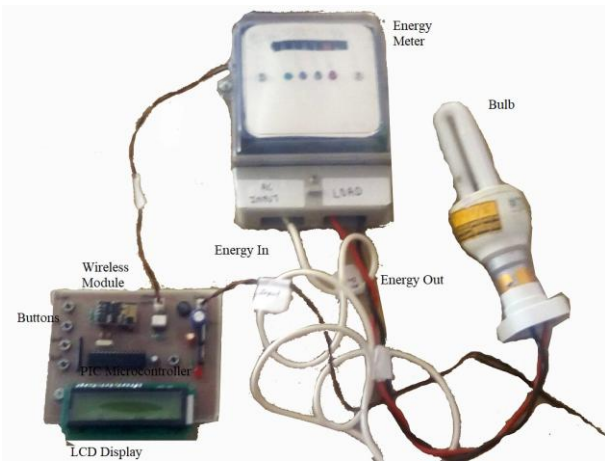

**Fig. 2 Prototype**

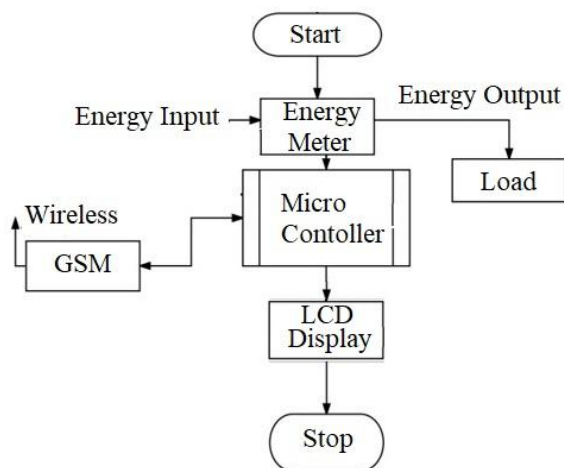

**Fig. 3 Work flow of the prototype**

**Table 1. Energy consumption details for five days**

Time	Energy Consumed (in Units)				
	Day 1	Day 2	Day 3	Day 4	Day 5
9.00 am	0	0	0	0	0
10.00 am	0.442	0.442	0.440	0.440	0.441
11.00 am	0.855	0.855	0.881	0.881	0.882
12.00 pm	1.326	1.327	1.321	1.321	1.324
1.00 pm	1.326	1.327	1.321	1.321	1.324
2.00 pm	1.767	1.77	1.763	1.762	1.765
3.00 pm	2.211	2.214	2.206	2.202	2.206
4.00 pm	2.654	2.657	2.648	2.643	2.206

**Table 2. Energy cost details for five days**

Time	Energy Cost (in Units)				
	Day 1	Day 2	Day 3	Day 4	Day 5
9.00 am	0	0	0	0	0
10.00 am	3.32	3.32	3.30	3.30	3.31
11.00 am	6.64	6.64	6.61	6.61	6.62
12.00 am	9.95	9.96	9.92	9.91	9.94
1.00 am	9.95	9.96	9.92	9.91	9.94
2.00 am	13.26	13.28	13.24	13.22	13.25
3.00 am	16.59	16.61	16.56	16.52	16.56
4.00 am	19.91	19.93	19.87	19.83	16.56

Table 1 and table 2 shows energy consumed details and cost details for the class room for five days. In day 1, Rs 3.32 is the cost for 0.442 units of energy consumed between 9.00 am to 10.00 am, Rs 3.32 is the cost for 0.443 units of energy consumed between 10.01 am to 11.00 am, Rs 3.31 is the cost for 0.441 units of energy consumed between 11.01 am to 12.00 pm, Rs 0 is the cost for 0 units of energy consumed between 12.01 pm to 1.00 pm, Rs 3.31 is the cost for 0.441 units of energy consumed between 1.01 pm to 2.00 pm, Rs 3.33 is the cost for 0.444 units of energy consumed between 2.01pm to 3.00 pm, Rs 3.32 is the cost for 0.443 units of energy consumed between 3.01 pm to 4.00 pm. Rs 19.91 is the cost for 2.654 units of energy consumed in day 1.

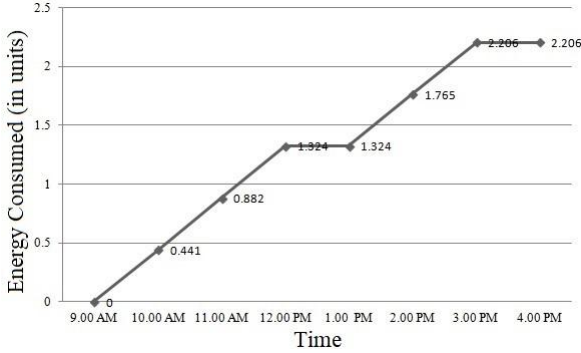

**Fig. 4 IOT Gecko server with energy consumption details and cost**

Figure 4 illustrate IOT Gecko server in which energy consumption details and their cost are updated. Account in IOT Gecko website is created with user name and password. In the profile section our name, email id, contact no, city, type all the thing are mention. When the energy meter icon is clicked, the system shows the energy consumed details and their cost.

# Prototype for Monitoring and Accessing Electricity Usage Details in Cloud using IoT Energy Meter

In day 2, Rs 3.22 is the cost for 0.442 units of energy consumed between 9.00 am to 10.00 am, Rs 3.32 is the cost for 0.443 units of energy consumed between 10.01 am to 11.00 am, Rs 3.22 is the cost for 0.442 units of energy consumed between 11.01 am to 12.00 pm, Rs 0 for 0 units of energy consumed between 12.01 pm to 1.00 pm, Rs 3.22 for the cost for 0.443 units of energy consumed between 1.01 pm to 2.00 pm, Rs 3.33 is the cost for 0.444 units of energy consumed between 2.01pm to 3.00 pm, Rs 3.32 is the cost for .443 units of energy consumed between 3.01 pm to 4.00 pm. Rs 19.93 is the cost for 2.657 units of energy consumed in day 2.



**Fig. 5 Energy Consumed details of Day 5**

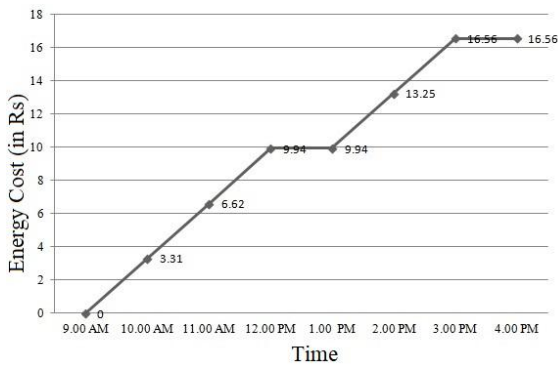

**Fig. 6 Energy Cost details of Day 5**

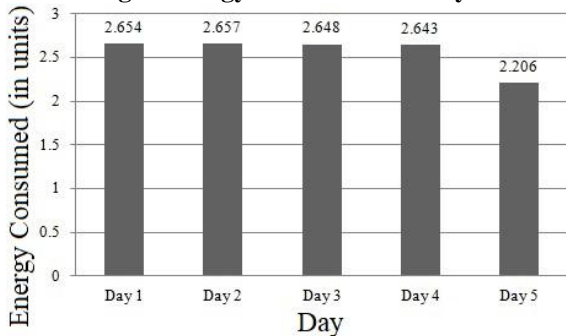

**Fig. 7 Energy Consumed details of 5 Days**

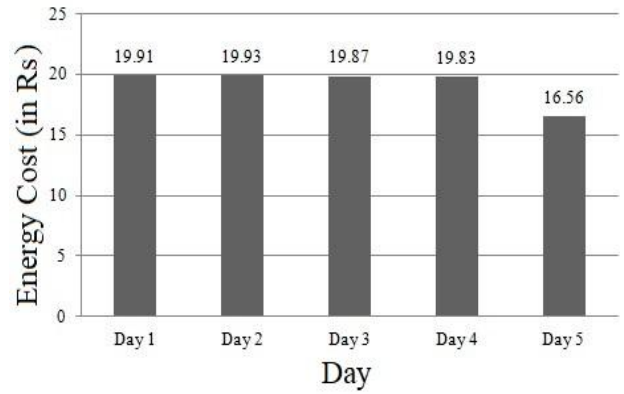

**Fig. 8 Energy Cost details of 5 Days**

In day 3, Rs 3.30 is the cost for 0.440 units of energy consumed between 9.00 am to 10.00 am, Rs 3.31 is the cost for 0.443 units of energy consumed between 10.01 am to 11.00 am, Rs 3.31 is the cost for 0.442 units of energy consumed between 11.01 am to 12.00 pm, Rs 0 is the cost for 0 units of energy consumed between 12.01 pm to 1.00 pm, Rs 3.32 is the cost for 0.442 units of energy consumed between 1.01 pm to 2.00 pm, Rs 3.32 is the cost for 0.443 units of energy consumed between 2.01pm to 3.00 pm, Rs 3.31 is the cost for 0.441 units of energy consumed between 3.01 pm to 4.00 pm. Rs 19.87 is the cost for 2.648 units of energy consumed in day 3.

In day 4, 0Rs 3.30 is the cost for .440 units of energy consumed between 9.00 am to 10.00 am, Rs 3.31 is the cost for 0.441 units of energy consumed between 10.01 am to 11.00 am, Rs 3.30 is the cost for 0.440 units of energy consumed between 11.01 am to 12.00 pm, Rs 0 is the cost for 0 units of energy is consumed between 12.01 pm to 1.00 pm, Rs 3.31 is the cost for 0.441 units of energy consumed between 1.01 pm to 2.00 pm, Rs 3.30 is the cost for 0.440 units of energy consumed between 2.01pm to 3.00 pm, Rs 3.31 is the cost for 0.441 units of energy consumed between 3.01 pm to 4.00 pm. Rs 19.83 is the cost for 2.643 units of energy consumed in day 4.

In day 5, Rs 3.31is the cost for 0.441 units of energy consumed between 9.00 am to 10.00 am, Rs 3.31 is the cost for 0.441 units of energy consumed between 10.01 am to 11.00 am, Rs 3.32 is the cost for 0.442 units of energy consumed between 11.01 am to 12.00 pm, RS 0 is the cost for 0 units of energy consumed between 12.01 pm to 1.00 pm, Rs 3.31 is the cost for 0.441 units of energy is consumed between 1.01 pm to 2.00 pm, Rs 3.31 is the cost for 0.441 units of energy consumed between 2.01pm to 3.00 pm, Rs 0 is the cost for 0 units of energy consumed between 3.01 pm to 4.00 pm. Rs 16.56 is the cost for 2.206 units of energy consumed in day 3. Results in figure 5 and figure 6 shows no energy is used during lunch time 12 pm to 1 pm and library hours 3 pm to 4 pm. Figure 5 shows hour wise energy consumption details and figure 6 shows hour wise energy cost details for day 5. Figure 7 shows day wise energy consumed details for 5 days. Figure 8 shows day wise energy cost details for 5 days.

Results show day 5 consumed less energy and energy cost low compared to other four days. This is because day 5 has library hour at 3 pm to 4 pm during that time energy is not used.

## VI. CONCLUSION

We have a prototype for monitoring, storing, accessing electricity usage details in cloud using IoT Energy Meter. Literature study on various IoT energy meters are done and came up with flexible design that allows user to select the unit cost for the energy consumed. Wifi connectivity is used for frequent up gradation of energy used details and their cost to server. User can access and analyze their hourly or daily usage details of the electricity using graphs and charts.

## REFERENCES

1. Ashna, K., and George, S.N., "GSM based automatic energy meter reading system with instant billing," International Mutli-Conference on Automation, Computing, Communication, Control and Compressed Sensing, pp. 65-72,(2013).
2. Darshan Iyer, N., and Radha Krishna Rao, K. A., "IoT Based Electricity Energy Meter Reading, Theft Detection and Disconnection using PLC modem and Power optimization," International Journal of Advanced Research in Electrical Electronics and Instrumentation Engineering, vol. 4, issue 7, pp. 6482-6491(2015).
3. Dinesh Prasanth, M.K., "Live Energy Meter Reading and Billing System through GPRS," International Journal of Engineering Research & Technology, Vol. 4, issue 5, pp. 255-299, (2014).
4. Gobinath, S., Gunasundari, N., and Gowthami, P., "Internet of Things (IOT) Based Energy Meter," International Research Journal of Engineering and Technology, Vol. 3, issue 4, pp. 1266-1269, (2016).
5. Karthikeyan, S., and Bhuvanawari, P.T.V., "IoT based real-time residential energy meter monitoring system," Trends in Industrial Measurement and Automation (TIMA), pp. 1-7, (2017).
6. Maity, T., and Das, P.S., "Intelligent Online Measurement and Management of Energy Meter Data through Advanced Wireless Network," 2011 International Conference on Devices and Communications (ICDeCom), pp. 1-4, (2011).
7. Preethi, V., and Harish, v., "Design and implementation of smart energy meter," 2016 International Conference on Inventive Computation Technologies (ICICT), pp. 1-5, (2016).
8. Primicanta, A.H., Mohd Yunus Nayan., and Awan, M., "ZigBee-GSM based Automatic Meter Reading system," 2010 International Conference on Intelligent and Advanced Systems, pp. 1-5, (2010).
9. Rashmi, M.N., and Mahadevaswamy, "IOT based Energy Meter Monitoring using ARM Cortex M4 with Android Application," International Journal of Computer Applications, vol. 150, no. 1, pp. 22-27, (2016).
10. Rawat, N., Rana, S., Yadav, B., and Yadav, N., "A review paper on automatic energy meter reading system," 3rd International Conference on Computing for Sustainable Global Development, pp. 3254-3257, (2016).
11. Tom Hargreavesn, Michael Nye, Jacquelin Burgess, "Making energy visible: A qualitative field study of how householders interact with feedback from smart energy monitors," Energy Policy, vol.38, pp. 6111-6119, (2010).

## AUTHORS PROFILE



**Dr. R. Jaichandran** is currently working as Head of the department CSE, Aarupadai Veedu Institute of Technology an ambit institution of Vinayaka Missions Research Foundation (Deemed to be University), Tamil Nadu, India. He has 13 years of experience in academics, industry, research, and development activities. Published 33 research papers in referred Journals and Conferences. His area of Interest includes Wireless Sensor Networks, Internet of Things (IoT), Ethical Hacking, Big data Analytics, and Embedded systems.



**Dr. S. Rajaprakashis** M.sc, M.Phil M.E Ph.D. currently working as Associate professor of CSE in Aarupadai Veedu Institute of Technology an ambit institution of Vinayaka Missions Research Foundation (Deemed to be University), Tamil Nadu, India. He has 17 years of experience in academics, research, and development activities. Published 17 research papers in referred Journals and Conferences. His area of Interest Artificial Intelligence, Computational Intelligence, Discrete Mathematics and Automata theory. Received grants from Tamil Nadu State Council for Science and Technology. He has peer Reviewed Manuscripts in reputed international Journals and Conferences. He is a member in following professional societies



**Dr. K. L. SHUNMUGANATHAN** is principal of AVIT & illustrious Professor in the Department of Computer Science and Engineering, AVIT. He has a vast experience in teaching, research & administration for more than 29 years at different levels. He earned his Ph.D from Anna University Chennai, in the area of AI& Networks, Master Engineering degree in of Computer Science and Engineering, Madurai Kamaraj University, and Bachelors degree in of Computer Science and Engineering from Bharathidasan University, Trichy. He has published over 147 papers in refereed International Journals and presented more than 42 papers in International and National conferences in India. : CSI and ISTE and Ramajunam Mathematics Society.



**Dr. Usha Kiruthika** is currently working as an Assistant Professor in the Department of Computer Science and Engineering in SRM Institute of Science and Technology, Kattankulathur Campus. She has completed her Ph.D at Anna University and she has many publications to her credit. Her areas of interest include artificial intelligence and deep learning.



**Mr. S. Muthuselvan** currently works as Assistant Professor Gr. II, Department of Computer Science and Engineering, Aarupadai Veedu Institute of Technology an ambit institution of Vinayaka Missions Research Foundation (Deemed to be University), Tamil Nadu, India. His area of the interests is Database Management System, Data Mining and Big Data. Published more than 25 international journals with Scopus indexed publications and conference. Also actively participating and organizing committee member for 4 international conferences, 2 national conferences. Having 15 years of teaching experience with 4 years of research experience. He is a member in CSI and Life member of ISTE. He has peer Reviewed Manuscripts in reputed international Journals and Conferences.