

Simulation Implementation of Three Phase VSI Fed Three Phase Induction Motor Drive with Filter



Amit Kumar Sharma

Abstract: Paper deals with an implementation of three phase induction motor fed from PWM voltage source inverter with RLC filter connected at the output of inverter. The analysis has been carried for under modulation range. The effect of modified modulation index on the rotor current, stator current, developed electromagnetic torque, line voltage and rotor speed of three phase induction motor is studied with the help of MATLAB/SIMULINK. The impact of the proposed approach on the transient and steady state response of the motor is included in the paper work. Paper also compares the total harmonic distortion in various parameters of inverter for different modulation index. Simulation is done on a three phase induction motor fed by a PWM voltage source inverter with filter which is developed in MATLAB/SIMULINK environment. There is appreciable improvement in THD of inverter line, phase voltage and current with increase in modulation index. The modified modulation method leads to the improvement in motor performance.

Keywords: Filter, MATLAB, Modulation Index, PWM, THD, Undermodulation.

I. INTRODUCTION

Three-phase inverters are used for variable-frequency drive applications. The conversion of dc voltage to ac voltage for the motor drive is done by three phase inverter [1]. The primary requirement of any three phase inverter is to produce a pure sinusoidal wave at its output. With the development of fast switching devices PWM VSI are extensively used, whose power devices switched at extremely high frequencies to drive the induction motor [2]. However harmonic components are induced in the voltage & current fed to the motor by its operation due to which current & voltage waves gets distorted [3]. Also the efficiency of induction motor decreases as its input shifts from sine wave operation [4]. To solve this problem one may filter this PWM voltage & obtain a sinusoidal output voltage [5]. The scope of this paper is simulation analysis of three phase induction motor Drive fed by pulse width modulated three phase inverter with filter connected at the output of inverter, by which Harmonics from the supply of utility application successfully filtered out by filters [6]. Paper also deals with the study of various parameters of three phase induction motor fed from three phase PWM VSI because alternative ways to diagnose the motor conditions by studying the transient processes of the

machine has been recently proposed [7]. The VSI output voltage is smoothed by LC filter & sinusoidal voltage is supplied into the motor [8]. High switching losses is one of the major problem with high power drive application inverters. PWM techniques are used to reduce this problem of switching losses [13] along with the improvement of inverter output voltage & current waves [9].

II. RESEARCH METHOD

Three phase SPWM inverter as well as induction motor drive for under modulation index is analyzed through the simulation model as shown in the fig 1. Although implementation of this technique is easy, its significant drawback is that it generate significant amount of undesirable harmonics along with fundamental term [10]. An RLC filter is connected at the output legs of inverter & various output parameters of inverter as well as induction motor drive is analyzed with the help of MATLAB/SIMULINK.

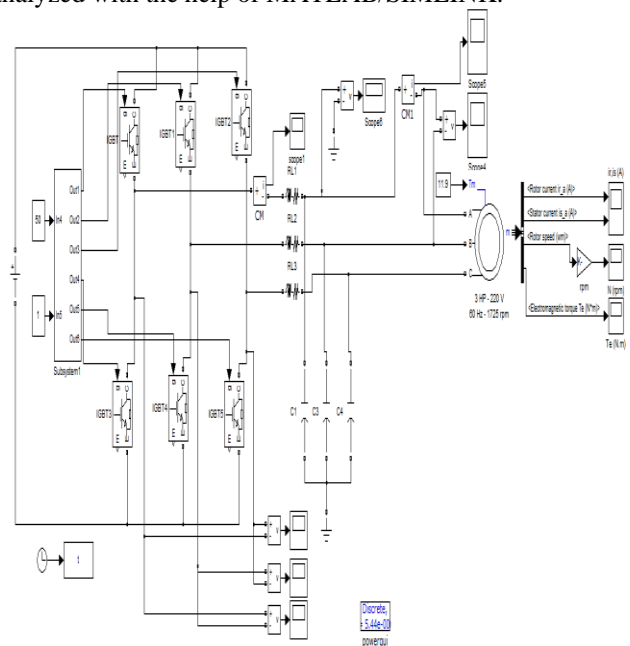

Fig.1: Diagrammatic representation of three phase induction motor supplied with PWM based VSI by RLC filter.

Fig 2 shows the output phase current of inverter without filter. Observe that the waveform is a impure sine wave which has distortion in it, this is due to the switching of various switches connected in the inverter. Because of this distortion the harmonic contents in this wave is more.

Fig 3 shows the output line voltage of the three phase inverter which is PWM wave.

Revised Manuscript Received on October 30, 2019.

* Correspondence Author

Amit Kumar Sharma*, Assistant Professor & Head, Department of Electrical Engineering, Uttarakhand Institute of Technology, Uttarakhand University, Dehradun, INDIA. Email: imamit04@gmail.com

© The Authors. Published by Blue Eyes Intelligence Engineering and Sciences Publication (BEIESP). This is an open access article under the CC BY-NC-ND license (<http://creativecommons.org/licenses/by-nc-nd/4.0/>)

We get the three waves at output terminal of the three phase inverter at the three legs which have 120° phase shift in between them. We can observe these waves on the three scopes connected at the different legs of the three phase PWM inverter as shown in Fig 1. Current of preferred frequency is obtained by rectangular voltage pulses of precise widths by this nature of drive [11].

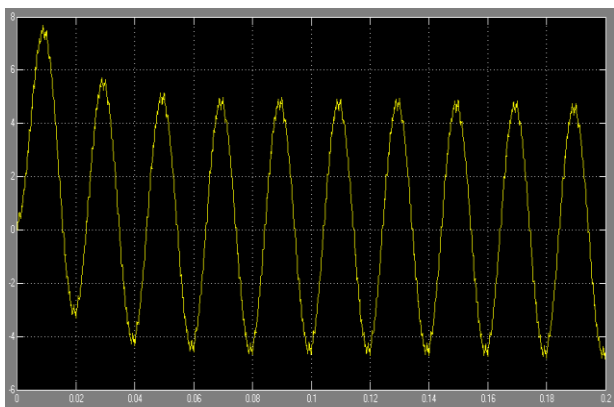

Fig.2: Phase current of inverter without filter

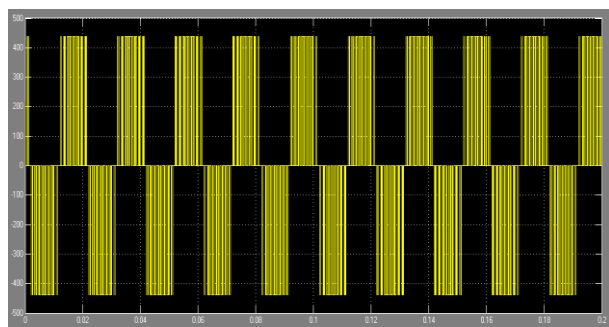

Fig.3: Line voltage of inverter without filter

III. RESULTS & DISCUSSION

A. For Modulation Index $m_a=0.7$

Now we analyze the waves at the output terminals of inverter after filtering with RLC filter. The values of RLC is taken as $R=5\text{ohm}$, $L=1\text{e-}1\text{H}$ & $C=1\text{e-}3\text{F}$. At these values we get pure sine wave after filtering. Fig 4 shows the output line current of inverter after filtering. Observe that the waveform of the line current is purely sine wave & it does not contain any distortion due to which the harmonics in the wave is reduced gradually because of filtering

As revealed in fig 5, a pure sine wave of line voltage is obtained at the output terminal of inverter after filtering the PWM voltage wave. Here observe that the magnitude of the voltage wave is reduced gradually after filtering. This is because of drop in the RLC filter.

The variation of rotor & stator current of motor of phase 'a' with respect to time is shown in fig 6. Observe that due to the filtered input of motor these waves do not have any transient time they only have steady state part & is purely sinusoidal. Fig 7 shows the speed of rotor which rises linearly to attain its steady state value.

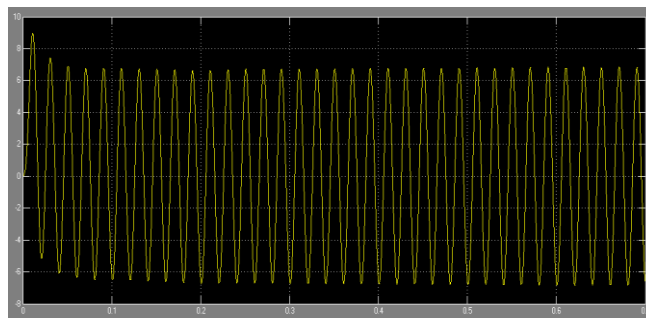

Fig 4. Line current of inverter after filtering for $m_a=0.7$

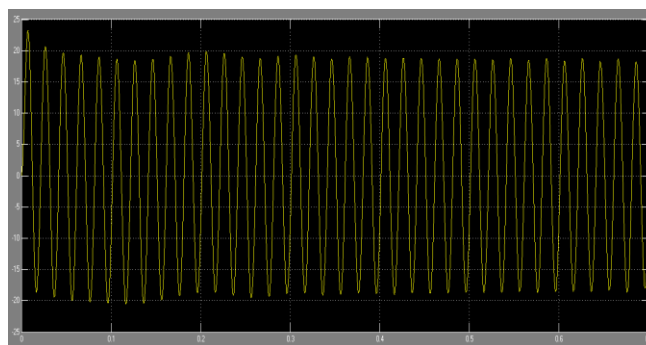

Fig 5. Line voltage of inverter after filtering for $m_a=0.7$

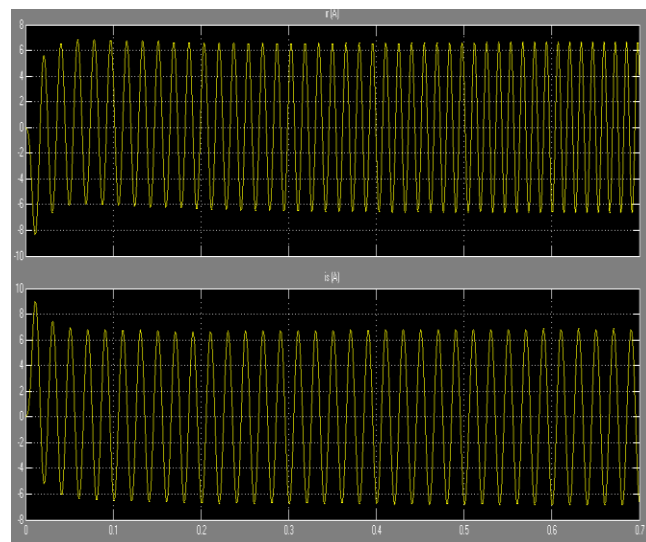

Fig 6. Waveforms of rotor and stator current of phase 'a' of three phase induction motor for $m_a=0.7$

Fig 8 shows the variation of electromagnetic torque developed by the motor. It is again observed that the developed electromagnetic torque is highly oscillatory initially & attain the steady state value after 0.35 seconds.

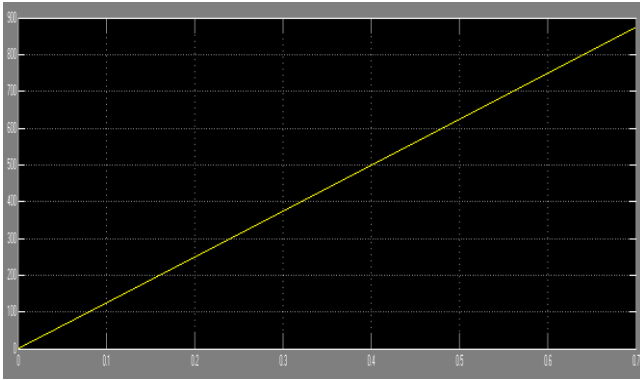

Fig 7. Rotor speed in rpm for $m_a=0.7$

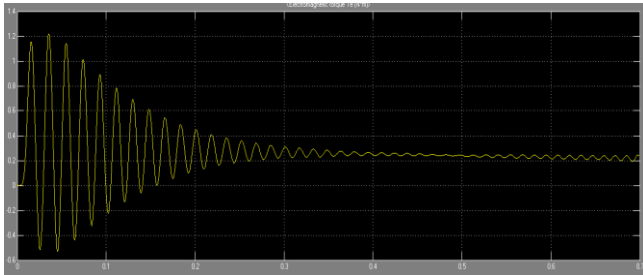

Fig 8. Waveform for the developed electromagnetic torque in N-m

Frequency spectrum of line voltage ‘ab’ & line current ‘a’ of inverter after filtering is shown in fig 9 & fig 10. From the frequency spectrum of these quantities observe that after filtering the Total Harmonic Distortion (THD) is reduced to lower values. We observe that the THD in line voltage is 0.37% & the fundamental component is 19.53 V, whereas in the line current of inverter the value of THD is 0.28% & the fundamental component present in it is 6.622 A for modulation index $m_a=0.7$.

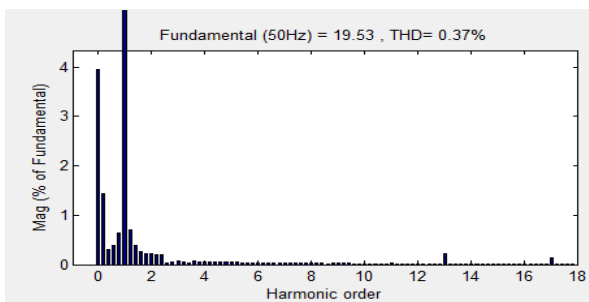

Fig 9. THD in Line voltage ‘ab’ for $m_a=0.7$

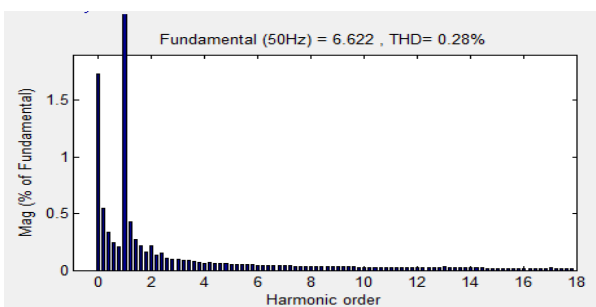

Fig 10. THD in Line current ‘a’ for $m_a=0.7$

Similarly inverter output phase voltage ‘a’ frequency spectrum is out fig 11 & it is observed that only 0.55% THD is present in it.

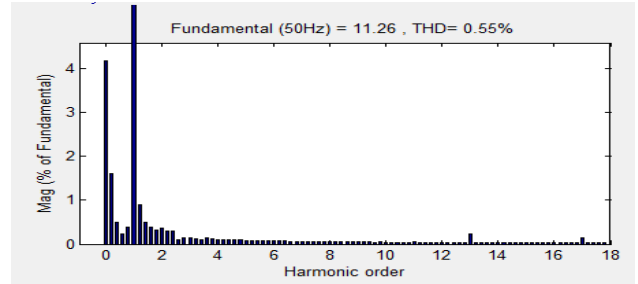

Fig 11. THD in Phase voltage ‘a’ for $m_a=0.7$

Thus for modulation index $m_a=0.7$ frequency spectrum analysis of various waves is listed in table 1.

Table 1: Frequency spectrum analysis of inverter output waves for $m_a=0.7$

S.No.	Wave	THD %	Fundamental Component
1	Line Voltage	0.37%	19.53 V
2	Phase Voltage	0.55%	11.26V
3	Line Current	0.28%	6.622 A

B. For Modulation Index $m_a=0.8$

Now the value of modulation index is increased from 0.7 to 0.8. The variation of line current & line voltage of inverter with respect to time is shown in fig 12 & fig 13. From the waveform of line current & line voltage it is observed that the magnitude of line current decreases slightly & that of line voltage are increases as we increase the modulation index to 0.8

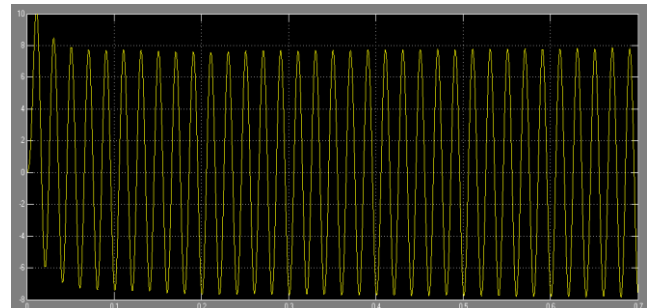

Fig 12. Line current of inverter after filtering for $m_a=0.8$

Fig 14 show that the stator current of motor is reduce slightly as we increased the value of modulation index where as there is no effect on the rotor current of the motor. Again both the waves are purely sinusoidal & do not have any transient part.

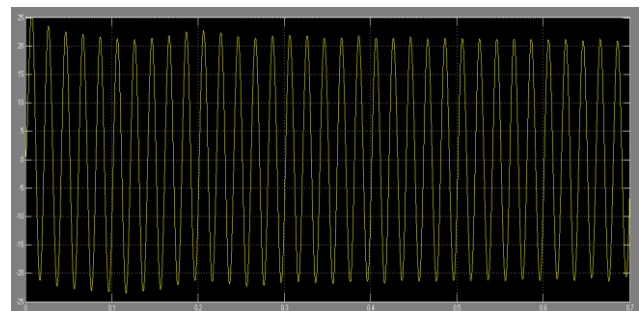

Fig 13. Line voltage of inverter after filtering for $m_a=0.8$

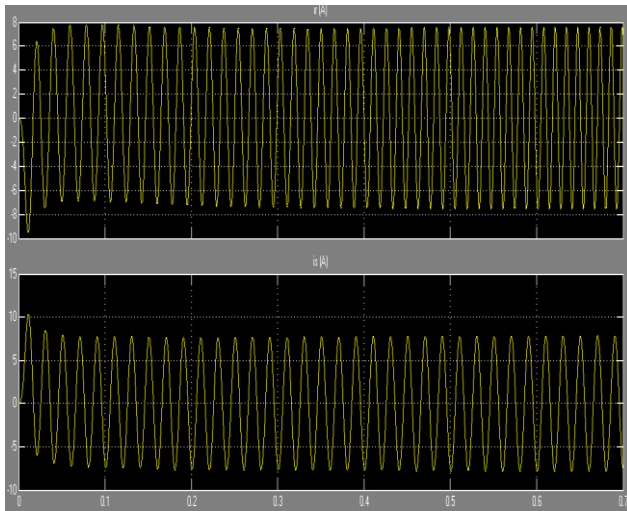

Fig 14. Waveforms of rotor and stator current of phase 'a' three phase induction motor for $m_a=0.8$

The variation of rotor speed with respect to time is shown in fig15 & it is observed that the speed increases linearly towards its steady state value.

Variation of electromagnetic torque developed is shown in fig 16. Torque ripples get reduced because of good quality of output voltage [12]. It is observed that the initial torque developed by the motor is again highly oscillatory but it decreases to its final steady state value as the time increases.

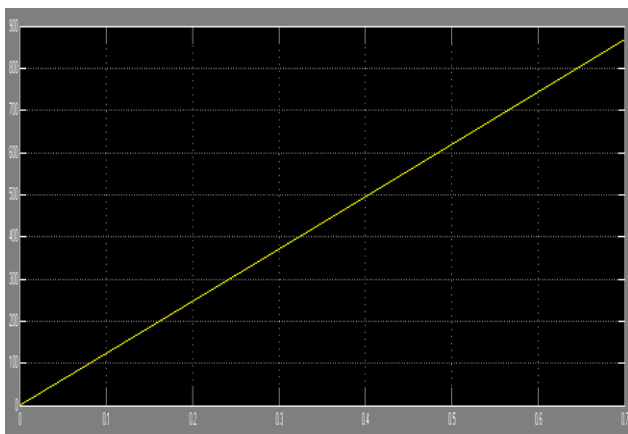

Fig 15. Rotor speed in rpm for $m_a=0.8$

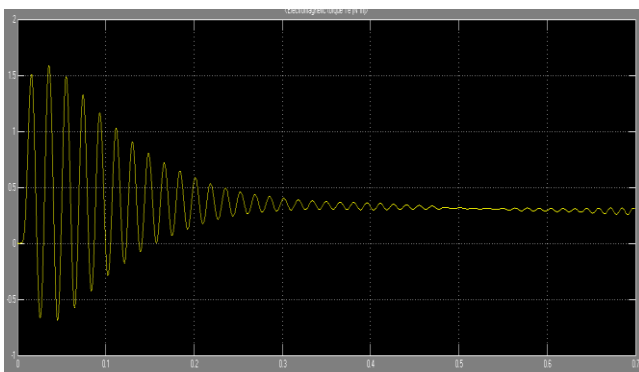

Fig 16. Waveform for the developed electromagnetic torque in n-m for $m_a=0.8$

From the spectrum of line voltage 'ab' of inverter it is found that the value of THD is reduce to 0.36% & its fundamental is increased to 19.53 to 22.32 as the value of modulation index is increased to $m_a=0.8$ as shown in fig 17.

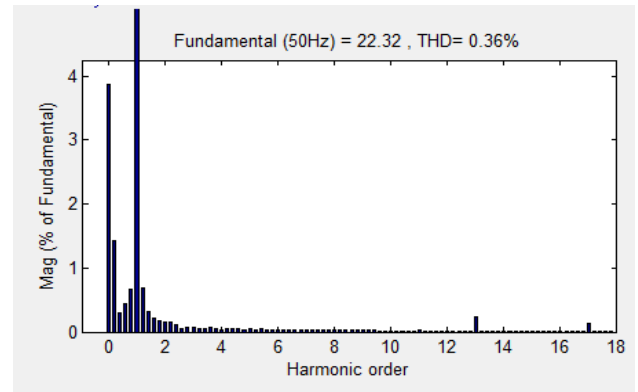

Fig 17. THD in Line voltage 'ab' for $m_a=0.8$

Similarly from the frequency spectrum of line current & phase voltage as shown in figure 18 & figure 19 , it is Observed that as we increase the modulation index to 0.8 THD is reduced to 0.22% from 0.28% in line current & 0.47% from 0.55% in phase voltage, while the fundamental component is increased to 7.564 in line current & 12.82 in phase voltage.

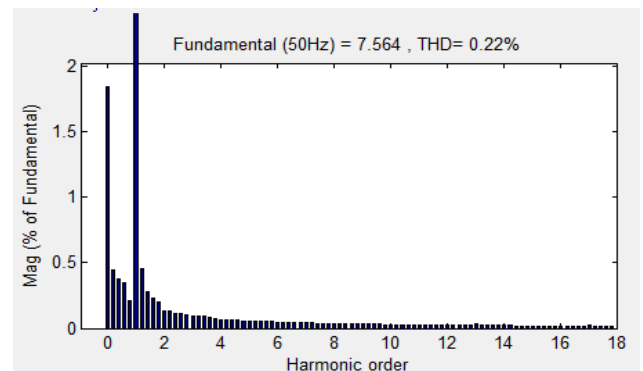

Fig 18. THD in Line current 'a' for $m_a=0.8$

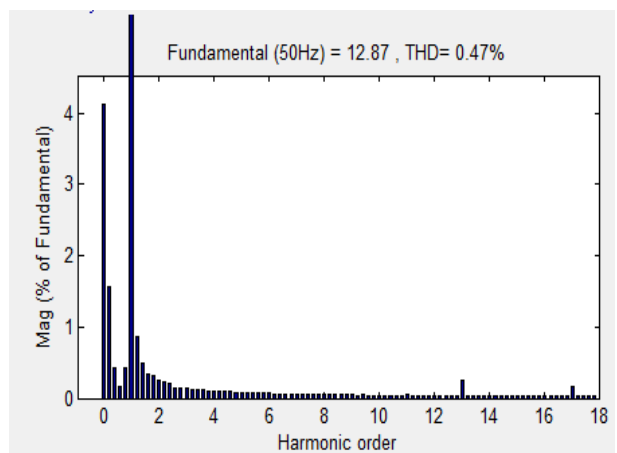

Fig 19. THD in Phase voltage 'a' for $m_a=0.8$

Results obtained from frequency spectrum for modulation index $m_a=0.8$ is listed in table 2.

Table 2: Frequency spectrum analysis of inverter output waves for $m_a=0.8$

S.No.	Wave	THD %	Fundamental Component
-------	------	-------	-----------------------

1	Line Voltage	0.36%	22.32 V
2	Phase Voltage	0.47%	12.87V
3	Line Current	0.22%	7.564 A

C. For Modulation Index $m_a=0.9$

Now the value of modulation index is further increased from $m_a=0.8$ to 0.9 & performance of various parameters of inverter as well as of the three phase induction motor are observed. Again the variation of filtered line current & line voltage with respect to time of three phase inverter is shown in fig 20 & fig 21 & it is observed that the magnitude line voltage again increases slightly. Thus we see that as we increases the modulation index from $m_a=0.7$ to $m_a=0.9$ the magnitude of output line voltage increases.

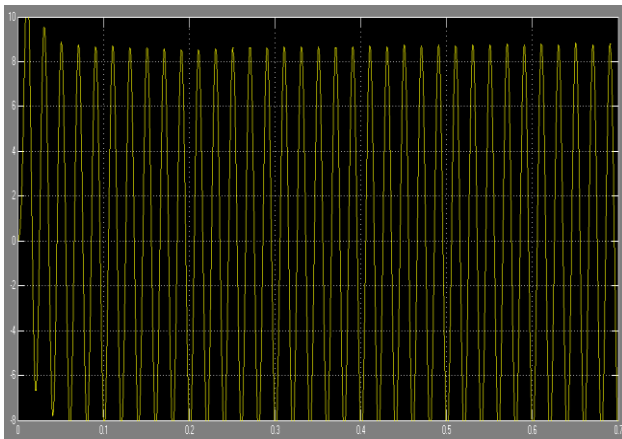

Fig 20. Line current of inverter after filtering for $m_a=0.9$

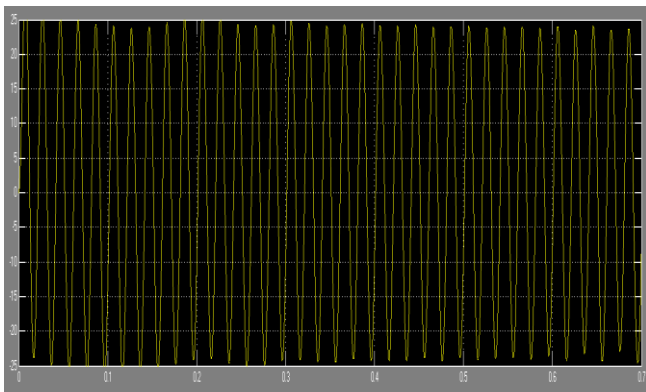

Fig 21. Line voltage of inverter after filtering for $m_a=0.9$

Fig 22 shows variation of rotor & stator current of the motor for modulation index $m_a=0.9$. Again it is found from the waveforms of stator current that its magnitude is reduced slightly. Fig 23 & Fig 24 shows the Waveforms of the rotor speed & developed electromagnetic torque of the motor.

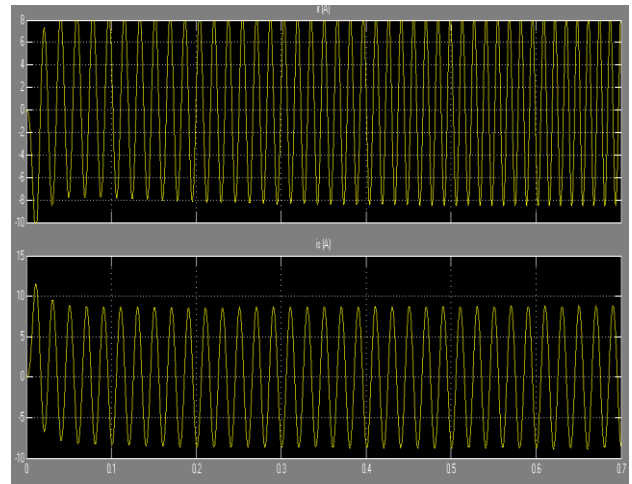

Fig 22. Waveforms of rotor and stator current of phase 'a' of three phase induction motor for $m_a=0.9$

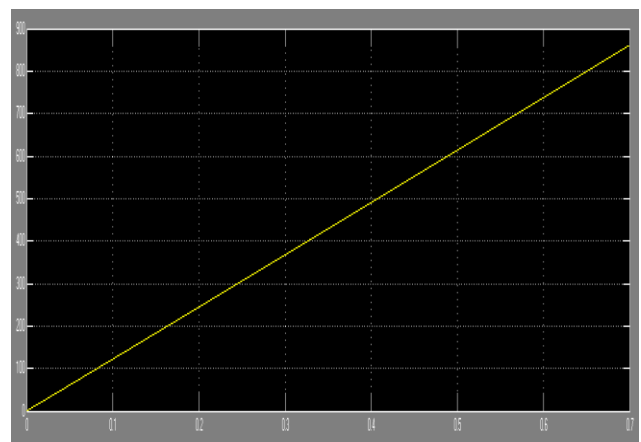

Fig 23. Rotor speed in rpm for $m_a=0.9$

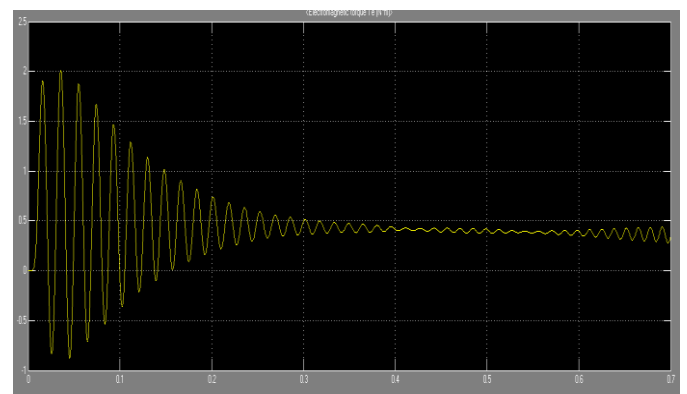

Fig 24. Waveform for the developed electromagnetic torque in N-m for $m_a=0.9$

Frequency spectrum for line voltage 'ab' & line current 'a' is shown in fig 25 & fig 26.

Observe that the value of THD in line voltage is again reduce to 0.37% & the value of fundamental component is increased to 25.1 while that of in line current THD is reduced to 0.21% & the value of fundamental is increased to 8.513.

Fig 27 shows the frequency spectrum of phase voltage of inverter after filter. Here again the value of THD is reduced to 0.47%.



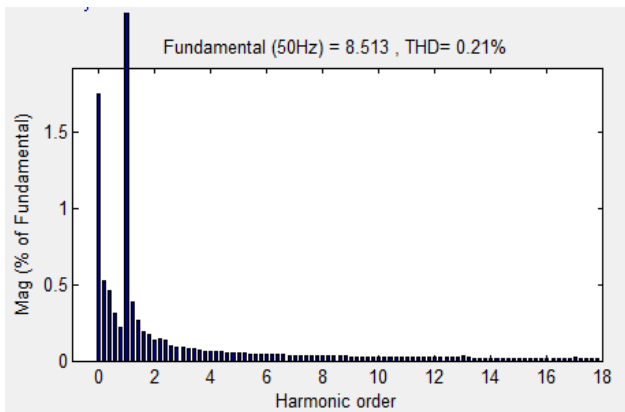

Fig 25. THD in Line voltage 'ab' for $m_a=0.9$

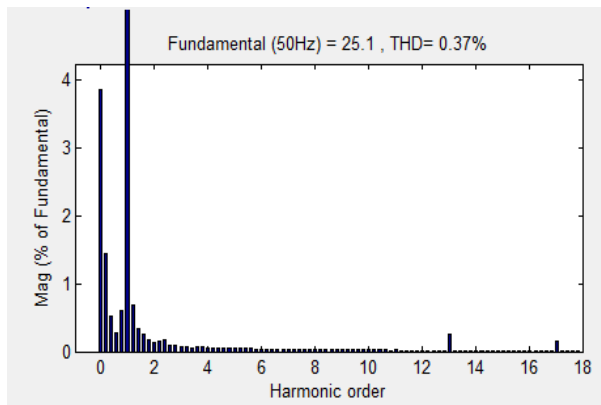

Fig 26. THD in Line current 'a' for $m_a=0.9$

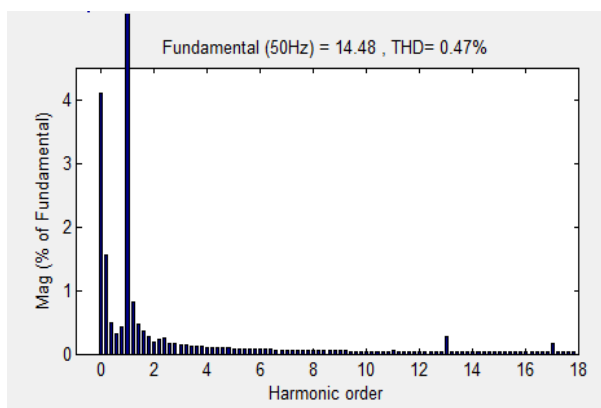

Fig 27. THD in Phase voltage 'a' for $m_a=0.9$

For modulation index $m_a=0.9$ frequency spectrum analysis of various waves is listed in table 3.

Table 3: Frequency spectrum analysis of inverter output waves for $m_a=0.7$

S.No.	Wave	THD %	Fundamental Component
1	Line Voltage	0.21%	8.513 V
2	Phase Voltage	0.47%	14.48 V
3	Line Current	0.37%	25.1 A

Thus we conclude that as we increases the value of modulation index the THD in various waveforms reduced & THD is reduced to minimum value because of the presence of RLC filter.

IV. COMPARISON IN THE VALUES OF THD IN % IN LINE VOLTAGE 'AB', LINE CURRENT & PHASE VOLTAGE FOR DIFFERENT MODULATION INDEX

Following tables show the comparison in the line voltage & current & in phase voltage in terms of Total Harmonic Distortion for different values of modulation index when we use RLC filter at the output of inverter.

Table 4: Comparison in THD in line voltage 'ab' for different values of modulation index.

S.NO.	Modulation index m_a	Total harmonic distortion (THD) in %
1	0.7	0.37%
2	0.8	0.36%
3	0.9	0.37%

Table 5: Comparison in THD in line current 'a' for different values of modulation index.

S.NO.	Modulation index m_a	Total harmonic distortion (THD) in %
1	0.7	0.28%
2	0.8	0.22%
3	0.9	0.21%

Table 6: Comparison in THD in phase voltage for different values of modulation index.

S.NO.	Modulation index m_a	Total harmonic distortion (THD) in %
1	0.7	0.55%
2	0.8	0.47%
3	0.9	0.47%

V. CONCLUSION

It is concluded that when we use the RLC T-filter on the output of three phase inverter, amount of harmonics in various quantities of inverter is reduced tremendously and comes to very lower values. It is observed that we get a pure sinusoidal waveform of various quantities of three phase inverter. Due to the presence of filter on the output terminal of three phase inverter the magnitude of output phase voltage & line voltage of the inverter is reduced hence its average RMS value is reduced though we get pure sine waves. Hence filter makes the output of inverter from pulsed wave towards the sine wave with the reduction in its magnitude.

With the increase the modulation index towards unity it is observed from the waveforms of inverter output voltage that their magnitude is increased by some amount, hence average RMS values of inverter output line voltage is increased with the increased in modulation index m_a . Total Harmonic Distortion in output voltage & current of inverter also reduces with the increase in modulation index m_a towards unity. Thus by controlling the modulation index we can control the THD & magnitudes of various output qualities of inverter.

Due to the filtering of output waves of inverter we get a pure sinusoidal current & voltage waves at the input of the three phase induction motor.

It is observed that with the increase in modulation index output voltage of inverter increases slightly but the stator current of the three phase induction motor decreases. Because of the pure sine input we observe that the transient part of the stator & motor current vanishes which increases the motor performance in terms of its developed electromagnetic torque & speed.

REFERENCES

1. Dehong Zhou, Jin Zhao and Yunhua Li, "Model-Predictive Control Scheme of Five-Leg AC-DC-AC Converter-Fed Induction Motor Drive" IEEE transactions on industrial electronics, VOL. 63, NO. 7, JULY 2016.
2. Anirudh Guha and G. Narayanan, "Small-Signal Stability Analysis of an Open-Loop Induction Motor Drive Including the Effect of Inverter Dead time" IEEE transactions on industry applications, VOL. 52, NO. 1, January/February 2015.
3. Michael M. Bech, John K. Pedersen, and Frede Blaabjerg, "Field-Oriented Control of an Induction Motor Using Random Pulse width Modulation" IEEE transactions on industry applications, VOL. 37, NO. 6, November/December 2001.
4. David G. Dorrell, Chee Yeow Leong and Richard A. McMahon, "Analysis and Performance Assessment of Six-Pulse Inverter-Fed Three-Phase and Six-Phase Induction Machines" IEEE transactions on industry applications, VOL. 42, NO. 6, November/December 2006.
5. Suvajit Mukherjee and Gautam Poddar, "Fast Control of Filter for Sensorless Vector Control SQIM Drive with Sinusoidal Motor Voltage" IEEE transactions on industrial electronics, vol. 54, no. 5, October 2007.
6. Abdul Rahiman Beig, and V. T. Ranganathan, "A Novel CSI-Fed Induction Motor Drive" IEEE transactions on power electronics, VOL. 21, NO. 4, July 2006.
7. Daniel Morinigo-Sotelo, L. A. Garcia-Escudero, Oscar Duque-Perez, and Marcelo Perez, "Alonso Practical Aspects of Mixed-Eccentricity Detection in PWM Voltage-Source-Inverter-Fed Induction Motors" IEEE transactions on industrial electronics, VOL. 57, NO. 1, January 2010.
8. Kamalesh Hatua, Amit Kumar Jain, Debmalya Banerjee, and V. T. Ranganathan, "Active Damping of Output LC Filter Resonance for Vector-Controlled VSI-Fed AC Motor Drives" IEEE transactions on industrial electronics, VOL. 59, NO. 1, JANUARY 2012.
9. Abdul Rahiman Beig and V. T. Ranganathan, "A Novel CSI-Fed Induction Motor Drive" IEEE transactions on power electronics, VOL. 21, NO. 4, July 2006.
10. A. Ruiz-González, F. Vargas-Merino, J. R. Heredia-Larrubia, M. J. Meco-Gutiérrez, and F. Pérez-Hidalgo, "Application of Slope PWM Strategies to Reduce Acoustic Noise Radiated by Inverter-Fed Induction Motors" IEEE transactions on industrial electronics, VOL. 60, NO. 7, July 2013.
11. Greg C. Stone, Howard G. Sedding, and Connor Chan, "Experience with Online Partial-Discharge Measurement in High-Voltage Inverter-Fed Motors" IEEE transactions on industry applications, VOL. 54, NO. 1, January/February 2018.
12. Viju Nair R, K. Gopakumar, and Leopoldo G. Franquelo, "A Very High Resolution Stacked Multilevel Inverter Topology for Adjustable Speed Drives" IEEE transactions on industrial electronics, VOL. 65, NO. 3, March 2018.
13. Atif Iqba, Sk Moin Ahmed, Mohammad Arif Khan, Haitham Abu-Rub, "Generalised simulation and experimental implementation of space vector PWM technique of a three-phase voltage source inverter" International Journal of Engineering, Science and Technology Vol. 2, No. 1, 2010, pp. 1-12

AUTHOR PROFILE



Mr. Amit Kumar Sharma –Assistant Prof. & Head - Dept. of Electrical Engineering. UIT Uttarakhand University Dehradun India. He has a flourishing career of Eight years in Teaching. He had his **B.Tech.** Degree in **Hons.** in Electrical & Electronics Engineering from one of the renowned colleges of UPTU Lucknow U.P India.. He has also completed his **M.Tech.** Degree in **Hons.** in Power Electronics & Drives. His academic career also consists of many research/review papers published in international journals conferences which are cited by many authors globally. His area of research includes Power Electronics, Electric Drives & Control system.