

# Bomb detection and disposal robot: Aid for risky Military Fields



S.Keerthana, AR.Vellaiyan, M.Rajamohan

**Abstract:** *Countless number of news items dealing with injured trained personnel or military people who loses their lives during defusing bombs appears daily in newspapers around the world. Here a robotic arm is designed to detect and dispose a bomb which is located around the range of 100m with safety and to provide a security for the bomb disposal squad against risks. The designed robot is manually controlled by the user through Personal Computer (PC).The buzzer alarm when the sensor detects a metal. The metal is examined with the help of the wireless camera that checks whether it is a bomb or not. If the detected metal is a bomb then the user controls the robot through PC and disposes the bomb. Arduino Mega board, DC motors, Robotic arm, wireless camera, Buzzer forms a part of designed robot. Initially setup is simulated using proteus software and then entire hardware setup is controlled through personal computer.*

**Index Terms:** *Arduino Mega board, trained personnel, bombs, buzzer, Personal Computer, Proteus*

## I. INTRODUCTION

Now-a-days the need for military robots has increased enormously. Thus competent robots begin to evolve. A part of Robotic platform such as remotely operated vehicles performs hazardous activities in civilian and military environment. Developing and employing such robots could substitute humans by performing many dangerous functions. The information about the observed environment is passed to the human operator. The machine is controlled by the human operator through teleoperation. For both military and police forces it is a greatest menace to hold explosive devices. Recent developments have yielded new interest in bomb disposal robots and techniques. The aim is to disarm the device with little human contact. The bomb must be safely disarmed without being exploded. The bomb should be detonated in a safe area ensuring nothing around in that area. Here electrically powered and distantly controlled robot is designed to locate, handle and destroy hazardous objects.

Revised Manuscript Received on October 30, 2019.

\* Correspondence Author

**S Keerthana\***, Assistant Professor, Department of ECE, Mepco Schlenk Engineering College, Sivakasi, India.

**AR.Vellaiyan**, UG Student, Department of ECE, Mepco Schlenk Engineering College, Sivakasi, India.

**M.Rajamohan**, UG Student, Department of ECE, Mepco Schlenk Engineering College, Sivakasi, India.

© The Authors. Published by Blue Eyes Intelligence Engineering and Sciences Publication (BEIESP). This is an [open access](https://creativecommons.org/licenses/by-nc-nd/4.0/) article under the CC BY-NC-ND license (<http://creativecommons.org/licenses/by-nc-nd/4.0/>)

## II. LITERATURE SURVEY

Paper [1] discusses the use of robot in rescue and search mission. Here RF technology is used to control the robot wirelessly. The obstacles are detected using Ultrasonic sensor. Smartphone camera attached to the robot provides omnidirectional view, thus facilitating complete control of robot. From paper [3], Robots are referred as Unmanned ground vehicles or self-controlled robots as it finds application in Border patrol, surveillance and in active combat. Human navigation commands guides the robot to travel from one point to another. Paper [4] illustrates how human hand movements could direct the robotic motor. Here specific mode of operation is used such as hand wave mode or gesture controlled mode. Paper [7] deals with PC-Based Robotic arm (PC- ROBOARM) which is developed to prove the results obtained by simulation. Here computer software called Smart arm is used for robotic arm design and control solution. It also deals with six degrees of freedom.

## III. HARDWARE DESCRIPTION

### A. Arduino MEGA (ATmega 2560)

Arduino Mega refers to a microcontroller board which is based on ATmega 2560. It possesses 6 analog pins for input and 6 digital input/output pins. It has clock speed of about 16MHz. It requires 5V for its working.

### B. DC Motor

Nine 12V dc motors are used for construction of robot. Here four dc motors are used to control wheel movement, two dc motors are used for shoulder control, one dc motor for elbow control and two Battery Operated (BO) motors for gripper control. High torque, low revolutions per minute (RPM) are essential for military robots

### C. L293D Motor Driver Module

It is a 16-pin Integrated Circuit (IC) capable of controlling two sets of DC motors simultaneously. It has two H- Bridge circuits allowing high voltage to flow in either direction. Pin 2, 7 regulates the rotation of motor on left side while Pin 15, 10 regulates rotation of motor on right side. It achieves accurate and fast control of torque

### D. Radio Frequency (RF) Module

The robot is wirelessly controlled by RF module.



It works between 400 MHz to 500MHz. Here at transmitter side an encoder is used to encode parallel data to serial format while at receiver it is converted back to parallel stream. The function of encoder and decoder is illustrated in Fig.1

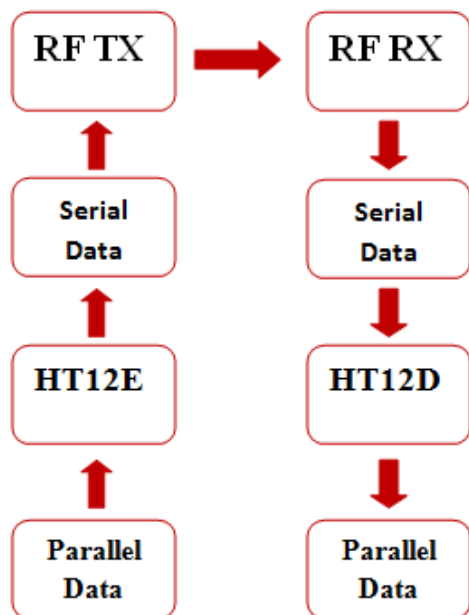

**Fig.1 Working Function of Encoder and Decoder module**

### E. Wireless camera

The video signals are captured from the sight that the robot monitors. These video signals are sent through the inbuilt antenna in the wireless camera. These signals are received on the user side with the help of the radio receiver. The radio receiver has a tuner which enables the user to tune the receiver for receiving the captured signal.

### F. Metal Detection Sensor Module

Metal detectors are employed for determining the existence of metal inclusions concealed within objects and also metal objects enclosed beneath the surface of the earth.

### G. Battery

A 12 V Lithium Acid battery is used to power the Robot. Also called SLI based on its function of Starting, Lighting and Ignition. It releases high burst of current and get quickly recharged.

### H. Robotic Arm

The robotic arm comprises of 3 dc motors and 2 BO motors. The 2 dc motors are used for the shoulder (base) movement which is used to control the front and backward arm movement, 1 DC motor aids the elbow movement and 2 BO motors are used for the gripper control for the picking up of the bomb

### I. Buzzer

If the robot detects the presence of bomb, the buzzer alarms.

Fig.2 describes interfacing of various blocks such as battery, DC motors, Robotic arm, Wireless camera, Metal detector, buzzer, RF module with ARDUINO Mega 2560 which forms entire Remote operated robotic module.

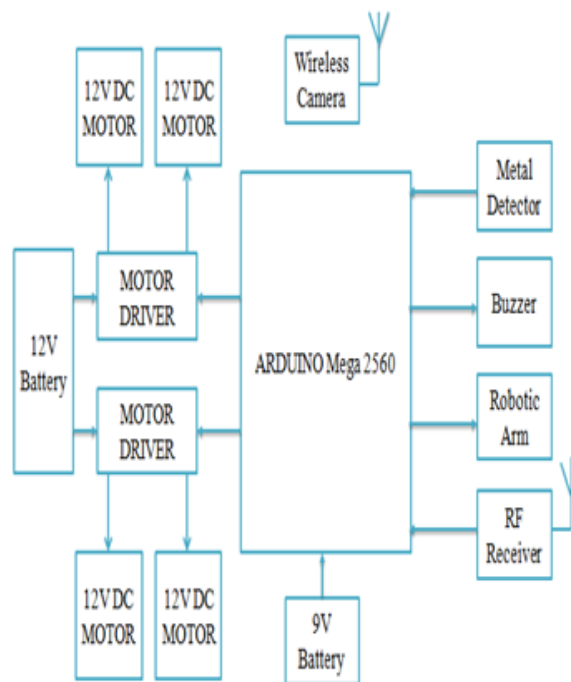

**Fig.2 Pictorial Representation of Robotic Block**

Fig.3 depicts the User control diagram for the designed robot.



**Fig.3 Block Diagram of User control**

## IV. SOFTWARE DESCRIPTION AND WORKING

### A. Software

Structure, values and functions are three main parts of Arduino programs. Here Arduino programs are written for controlling movement of robotic arms and rotation of motors. Arduino software IDE runs on cross platform and provide simple programming environment.

**B. Flow chart**

Fig. 4 explains the flow diagram of the operation of the designed robot

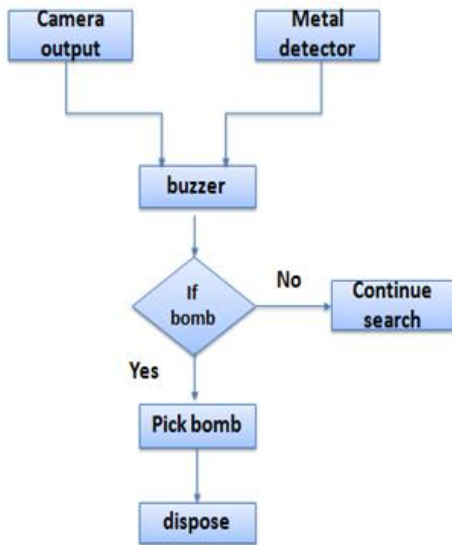

**Fig. 4 Flow chart showing the operation of designed robot**

**C. Algorithm**

1. User control is employed to control the robot at user end. The robot is controlled at the user end by employing wireless technology.
2. User control application is utilized by the bomb technician to monitor the robot
3. The programming for the robot is done through the Arduino coding. There are fourteen keys assigned for the robotic control.
4. When a bomb is detected by the sensor the buzzer alarms and the video output from the camera is used to compare the sensed material.
5. Serial Transmission of user input is done through an RF link to the robot. The robot acquires it, recognize it and relay it to the concerned module

**V. RESULTS AND DISCUSSIONS**

**A. Proteus simulation**

Proteus is a circuit simulation application. It eases co-simulation of complete microcontroller based designs. Fig.5 indicates the rotation of motor upon simulation

**B. Designed Robot**

Fig. 6 depicts the designed wireless bomb disposal robot. User sets the input to the system. User control application process the input. It is then transmitted through a Radio Frequency (RF) link which is picked by robot for processing. The processed signal is sent to the appropriate module. Hence the robotic arm module or motor can be controlled.

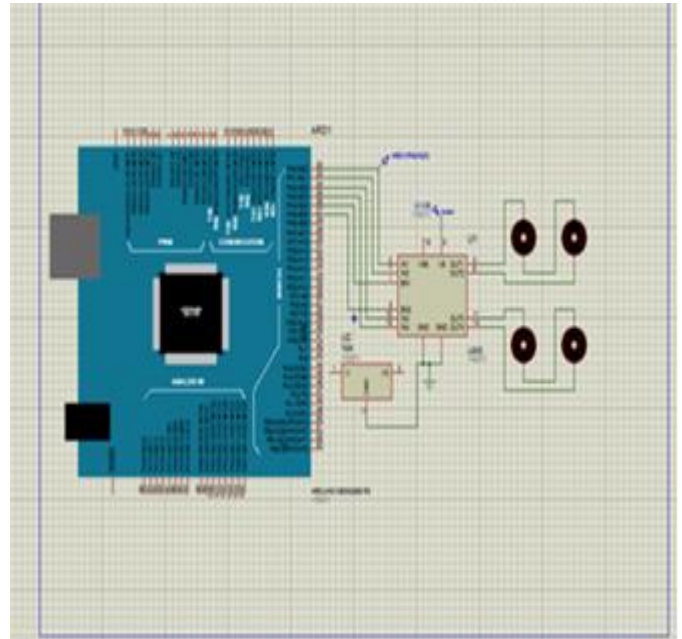

**Fig. 5 Simulation output. The entire circuit is drawn in proteus and is simulated**



**Fig. 6 Designed Wireless bomb disposal robot**

**C. Controlling the robot from Personal Computer (PC)**

**Table1.** Controlling Keys assigned for Robotic Movement

S.No	Robot Movement	Key
1.	Forward Movement	2
2.	Backward Movement	8
3.	Movement towards Left	4
4.	Movement towards Right	6

The control for the robot (as listed from Table1 and Table2) is given from the PC through the serial monitor.

The Arduino code is dumped in the ATmega2650 and the



input is given from the serial monitor. From Fig.7 it is inferred that forward, backward, left, right movement of motor is controlled by 2, 8, 4, 6 while w, s, a, d control the forward, backward, elbow up, elbow down movement of robotic arm. By pressing q and e, the gripper in robotic arm expands and contracts that can be used for picking the metal object. Key 5 is pressed to make robot remain still.

**Table2.** Controlling Keys assigned for Robotic Arm Movement

S.No	Robot Arm Movement	Key
1.	Forward Movement	w
2.	Backward Movement	s
3.	Elbow up	a
4.	Elbow down	d
5.	Gripper Expands	q
6.	Gripper contracts	e

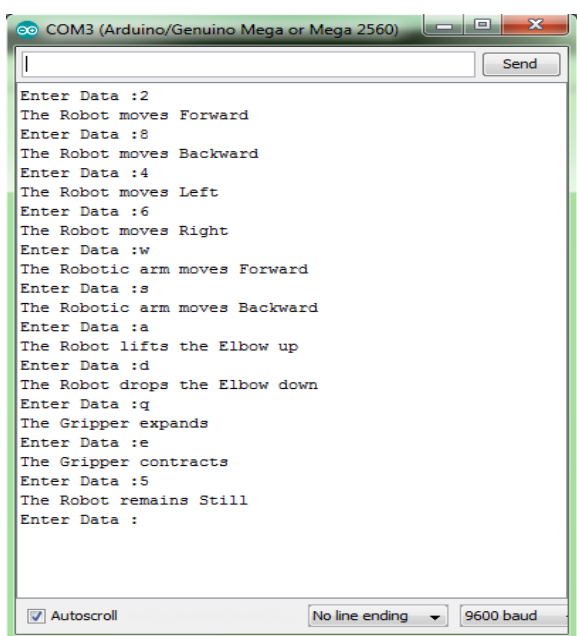

**Fig. 7** Controlling the robot from PC

## VI. CONCLUSION

Thus proposed system affords exposure to design of simple robots which aid military applications. Manual control is applied to remotely control the robot from control room. The rotation of DC motors is initially checked through simulation and then hardware setup of robot is built. Whenever buzzer alarms by detecting a metal, a wireless camera fixed in robot is utilized to verify whether it is a hazardous object. If so the robotic arm is manually controlled to disarm the bomb safely. Therefore designed robot could replace bomb disposal squad in military and police.

## VII. APPLICATIONS AND FUTURE EXTENSIONS

The designed robot can be employed in areas such as reconnaissance missions in military, handling radioactive wastes, safe disposal of bombs in police and military force. The characteristics and reliability of the designed prototype may not meet the actual design. The designed prototype

reveals the feasibility of the original design. The future scope of the work lies in large scale implementation of the designed robot, small sized robots, authentic and faster technology based bots and intelligence based robotic systems.

## REFERENCES

1. Balamurgan M. S, Sharma. A, "Mobile robotic system for search mission", International Conference on Innovations in Information, Embedded and Communication Systems (ICIIECS), 2015, pp.1-7.
2. Siddharth Narayanan, C. Ramesh Reddy , "Bomb Defusing Robotic Arm using Gesture Control", International Journal of Engineering Research & Technology (IJERT), 2015, pp. 1-7.
3. Mithileysh Sathiyarayanan, Syed Azharuddin, Santhosh Kumar, Gibran Khan, "Self-controlled robot for military purpose", International journal of technological research in Engineering, Vol.1, 2014, pp.1075-1077.
4. Mithileysh Sathiyarayanan, Syed Azharuddin, Santhosh Kumar, Gibran Khan, " Guesture Controlled robot for military purpose", International journal of technological research in Engineering, , Vol.1, 2014, pp.1300-1303.
5. Aydogdu. O, Unluturk. A, "Design and implementation of a mobile robot used in bomb research and setup disposal", International Conference on Electronics, Computers and Artificial Intelligence (ECAI), 2013, pp.1-6.
6. Premkumar. M, "Unmanned Multifunctional robot using Zigbee adpoter network for defense application", International journal of Advanced research in computer engineering and technology", 2013, pp. 47-55.
7. W. G. Hao, Y. Y. Leck, L. C. Hun, "6-DOF PC-Based Robotic Arm (PC-ROBOARM) with efficient trajectory planning and speed control", IEEE 4th International Conference On Mechatronics (ICOM), 2011, pp.53-56.
8. HongKai Li, ZhenDong Dai, "A semiautonomous sprawl robot based on remote wireless control", IEEE International Conference on Robotics and Biomimetic (ROBIO), 2010.
9. S. Tadokoro, "Special project on development of advanced robots for disaster response (DDT Project)", Proceedings of IEEE Workshop on Advanced Robotics and its Social Impacts (ARSO'05), 2005.
10. Dongseok, Ryu, Chang-Soon, Hwang. & Sungchul, Kang , "Wearable haptic-based multi-modal teleoperation of field mobile manipulator for explosive ordnance disposal", Proceedings of the 2005 IEEE International Workshop on Safety, Security and Rescue Robotics, 2005, pp. 75-80.

## AUTHORS PROFILE



**Mrs. S.Keerthana** obtained her B.E in ECE and M.E in Communication Systems. Currently she is working as Assistant Professor, Electronics and Communication Engineering, Mepco Schlenk Engineering College, Sivakasi, Tamil Nadu, India.



**AR.Vellaiyan** completed his B.E Electronics and Communication Engineering at Mepco Schlenk Engineering College, Sivakasi, Tamil Nadu, India.



**M.Rajamohan** completed his B.E Electronics and Communication Engineering at Mepco Schlenk Engineering College, Sivakasi, Tamil Nadu, India.