



IoT based Automatic Light Control with Temperature Monitoring and Alert mechanism

A. P. Nirmala, Prasenjit Kumar Das

Abstract: Currently, energy saving has become one of crisis that needs to be addressed by the entire world as it is known that energy saved is energy produced. Especially, power consumption at home plays a major role in energy saving. At times, the light is on when people forget to switch off the light while leaving the room. This may lead to waste of energy and economy issues. Thus, it is the need of the hour to propose automatic light control system that turns on and off automatically based on the human presence in the room. Sensors are used to detect the human presence in the room which automatically controls the light. Also, the proposed system alerts the user through mail when the room temperature is increased beyond certain level through temperature and humidity sensors.

Index Terms: Alert, Automatic Light Control, Cloud, IoT, Sensors.

I. INTRODUCTION

A. Nowadays conserving energy is serious concern [1] and in-efficient power consumption has an impact on energy saving. The electricity bill from cities in worldwide is 10-38% of total energy bill from lighting. To reduce the power consumption [7] and to reduce electricity bill at home, a smart lighting control approach can be proposed using various sensors. Especially, sensors which identify infrared radiation are utilized efficiently to conserve the power that benefits individual also. This provides the environment safe when turning the light on or off inside the room depending on whether the room is occupied or not [8]. Further, temperature sensor is used in the proposed model to measure the room temperature to alert the user when temperature level is increased upon certain limit.

Few related works are discussed in this section. LDR (Light Dependent Resistor) is used in a system [2] to control the street lights. In a day time, there is no need of light so LDR keeps the street light off. It turns the light on based on the light intensity as it is low during night time. In another work, Automation control system [3] was developed to control lamp and fan with micro controller and sensors. Automatic fan system used DHT11 sensor to find the temperature thus enabled the fan to switch on when the

temperature is greater than 25°C. Automatic lamp system used LDR to detect the intensity of the light and enable the lamp 'ON' when the light begins to darken.

In an automatic sliding door [4], when a person going near the door, it gets automatically opened based on the distance he/she from the door. The drawback of this system is that in certain situation where there is no power supply, if somebody trying to open the door forcefully can damage the system. Home Light Control Module [5] controlled the light to switch on or off based on the presence of human and also identified the intensity of the light in the place using light sensor which enable the light to be switched on or off.

II. PROPOSED SYSTEM

Automatic light control and temperature monitor system is proposed with the aim of sensing the presence of the object and whenever any person entering into the room, the light will glow and when there is no human movement in the room, the light will be switched off. This can be achieved with PIR (Passive Infrared Sensor) sensors. Also, this framework uses temperature and humidity sensor for measuring the temperature, humidity and storing the data into the cloud where if the temperature is more than the threshold level then it will alert the user by email.

Block diagram for the automatic light control and temperature monitoring system is shown in Fig. 1.

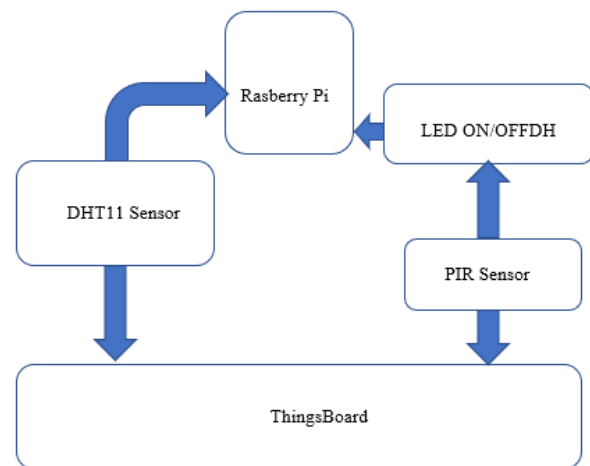

Fig. 1 Block diagram

Raspberry Pi 3b+ is used as a microprocessor in which PIR Sensor and DHT11 (Temperature and Humidity Sensor) are connected. First one is used for detecting the human presence and the latter is for monitoring the room temperature and humidity.

Revised Manuscript Received on October 30, 2019.

* Correspondence Author

Dr.A.P.Nirmala*, Associate Professor, Department of MCA, New Horizon College of Engineering, Bangalore, India.

Prasenjit Kumar Das, Department of MCA, New Horizon College of Engineering, Bangalore, India.

© The Authors. Published by Blue Eyes Intelligence Engineering and Sciences Publication (BEIESP). This is an open access article under the CC BY-NC-ND license (<http://creativecommons.org/licenses/by-nc-nd/4.0/>)

After getting the data from the temperature sensor, the values are sent to the cloud and it will keep on tracking the temperature and humidity. When it is increased from a given range then it will alert the user to inform on temperature increase. PIR sensor will detect the human presence in the room and the data is sent to the Raspberry pi. This enables LED to switch on and the same output will be reflected on to the Thingsboard platform. It is implemented with MQTT [9] (MQ Telemetry Transport) protocol which is used for sending the data to cloud and IoT level 4 [10] used to collect the data in the cloud from IoT devices. This section discusses the different components that are used in the system.

A. Raspberry pi 3b+

Raspberry Pi Foundation has built a single board computer called as Raspberry Pi with the goal of providing computer education to the people in the world. It also facilitates the user with easy way to get the education in computing. In 2012, Raspberry Pi was released and later on came up with lot of additions and flavors. Raspberry Pi has several applications such as home automation and smart industries. These types of computers are comparatively low cost and it supports Linux. It has General Purpose Input and Output pins which are dedicated to manage the electronic components for physical computing and deals with IoT. In the series of Raspberry Pi 3 Model [12], B+ is considered as the recent model with the following configuration as shown in Table I.

Table I Raspberry Pi 3Model B+ Configuration

Broadcom BCM2837B0
Cortex-A53 (ARMv8) 64-bit SoC @ 1.4GHz
1GB LPDDR2 SDRAM
2.4GHz and 5GHz IEEE 802.11.b/g/n/ac wireless LAN
Bluetooth 4.2 BLE
Gigabit Ethernet over USB 2.0 (maximum throughput 300 Mbps)
Extended 40-pin GPIO header
Full-size HDMI
4 USB 2.0 ports
CSI camera port for connecting a Raspberry Pi camera
DSI display port for connecting a Raspberry Pi touch screen display
4-pole stereo output and composite video port
Micro SD port for loading operating system and storing data
5V/2.5A DC power input
Power-over-Ethernet (PoE) support (requires separate PoE HAT)

B. DHT11 Sensor

It is a digital sensor which is used for measuring humidity and temperature [11]. The sensor determines the temperature and water vapor pressure in the surrounding by absorbing the moisture. For which, it uses capacitor and thermistor which are accurate and easy to use. However, the sensor can read new data for every two seconds. The DHT11 sensor connected with Raspberry pi is shown in Fig. 2.

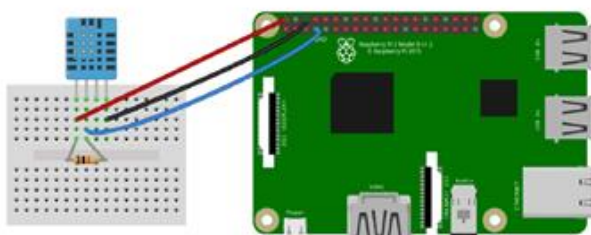

Fig. 2 DHT11 Connection with Raspberry Pi board

C. PIR Sensor

It is known as passive infrared sensor which is an electronic sensor [6] used to determine radiation emitted from the objects in the surrounding area. In motion detectors, these sensors are widely involved. This sensor is predominantly used in few applications such as automatic light and security alarms. It can trace the movement of the object but does not reveal the details about the object [12]. The Passive infrared sensors consist of three pins which are described in Table 2.

Table II Pin Configuration

Pin Number	Description
1	Pin 1 connects with device in drain terminal and it needs to be attached with positive supply 5V DC
2	Pin 2 connects with the device in source terminal and also with the ground terminal via a 100K or 47K resistor. It is the output pin of the sensor, and the detected infra-red signal is carried forward to an amplifier from this pin of the sensor
3	Pin 3 of the sensor connects with the ground.

This sensor has two slots which makes it more complicated compared with others. Infra-red radiations can be easily absorbed by these slots due to special material used on it. The sensors use Fresnel lens so as to reach out far distance. When there is no object movement, the slots can identify the same amount of infrared radiation which is emitted from the surroundings such as outdoors, walls or room. If an object passes by then it is captured in the first slot of the PIR sensor.

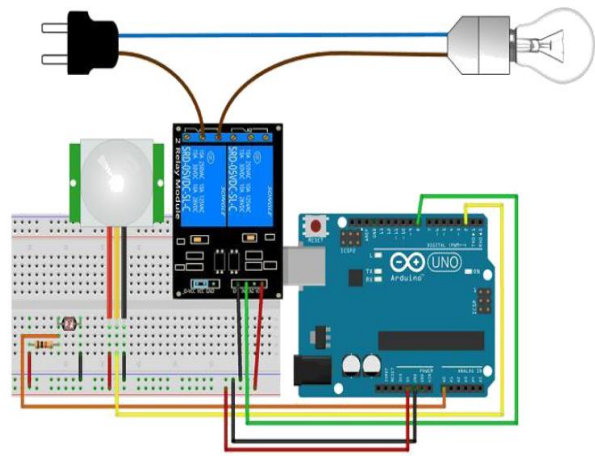

Fig.3 PIR Sensor and Relay Module connection with Raspberry pi board

Thus lead the sensor to create a positive differential change. Whereas the sensor shows a negative value if the person go away from the place. To improve the accuracy of humidity / temperature, the infra-red sensor is covered with sealed metal.. Sensing element is shielded with a window made of typically coated silicon material. Fig. 3 shows the connection of PIR sensors and 2 channels Relay Module with Optocoupler LOW level Trigger expansion board which is compatible with Raspberry Pi board.

D. Breadboard

It is a helpful to build temporary model and implement it with circuit model [13] as it is prototype design used in electronics. Due to this, solderless breadboards are considered as significant model in hi-tech education. [14].

III. RESULT AND DISCUSSION

The proposed system focuses on smart light and monitoring the temperature, humidity of a room. When a person enters the room, it turns light on and when they leave the room light will be turned off. Human movement inside the room is detected by PIR sensor and when it detects it will send signal to switch on the LED and the LED will glow as shown in Fig. 4. It will send signal to switch off the LED when there is no human presence.

In addition to that, the system monitors the room temperature and humidity. This can be achieved by DHT11 sensor which measures the temperature, humidity of the room and pass on the data to cloud in Thingsboard cloud platform.

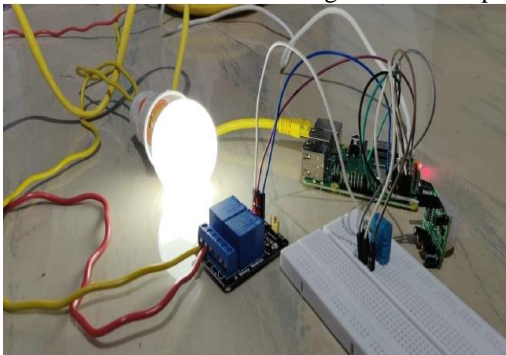

Fig. 4 Working model of Smart lighting System

Thingsboard is cloud platform where a dashboard is created in which two widgets are available for light and temperature; the results are shown according to the values. If light is 'ON' then the widget light will be displaying a message 'ON' in the dashboard and if it is off it will show 'OFF' in the dashboard is depicted in Fig. 5 a) and b).

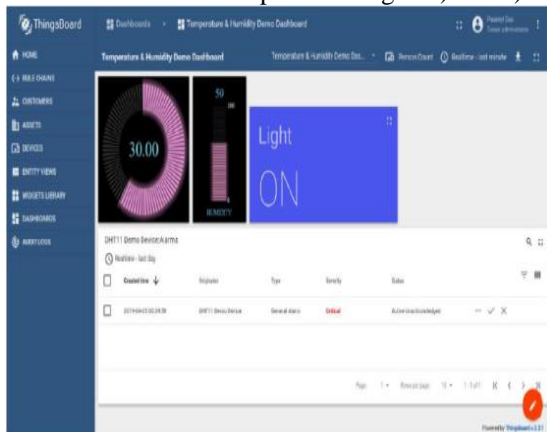

Fig. 5 a) Light Switched ON

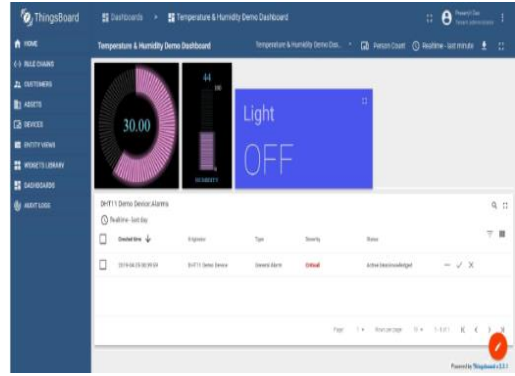

Fig. 5 b) Light Switched OFF

If the data received from temperature sensor and when the temperature increases more than 25°C then it creates the alarm. This notifies the user by sending an email that temperature is high as depicted in Fig. 6 a) and b). Here, SendGrid is used for sending email to user to alert. In Thingsboard, dashboard contains the temperature meter with alarms and a small widget that shows the user whether the light is on/off.

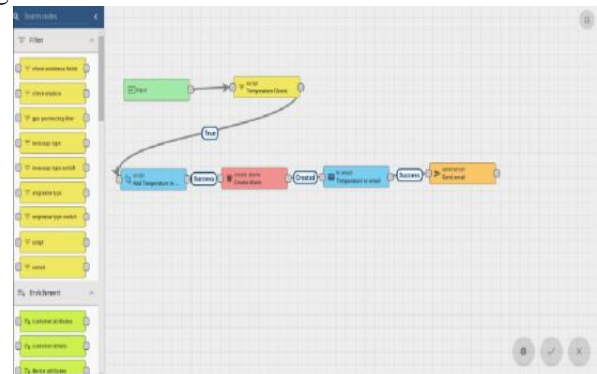

Fig. 6 a) Rules Chains for Sending email and creating an alarm



Fig. 6 b) Email received when alarm is triggered

IV. CONCLUSION

The proposed system reduces human effort by automatically switching the light on/off. PIR sensor is used to sense the human presence and it sends the signal to the relay module based on which it will switch on the light.



Also, temperature sensor measured the temperature in the room and the user is alerted through mail whenever increase in temperature beyond threshold. This work can be extended in future in such a way that the user can be notified through phone as well. The user can control the temperature through their smart phones and they can even switch off the light from the dashboard itself. The temperature sensing can be attached with the room AC and it can help the user to control the AC remotely.

REFERENCES

1. S. S. S. Ranjit, A. F. Tuani Ibrahim, S. I. M. Salim, and Y. C. Wong, "Door sensors for automatic light switching system, " in Proc. of EMS'09, pp. 574-578, 25-27 November, 2009.
2. Md. Sazol Ahmmed, Tanzima Zoha Chowdhury & Sourav Kumar Ghosh, "Automatic Street Light Control System Using Microcontroller ", Global Journal of Researches in Engineering: A Mechanical and Mechanics Engineering Volume 18 Issue 1 (Ver. 1.0), 2018
3. V T Widyaningrum, Yoga Pramudita, "Automatic Lamp and Fan Control Based on Microcontroller", Journal of Physics Conference Series 953(1):012146, January 2018
4. A.M. Zungeru, P.O. Abraham-Attah, A Digital Automatic Sliding Door with a Room Light Control System, 1303.1728, 2013.
5. Y. W. Bai and Y. T. Ku, "Automatic room light intensity detection and control using a microprocessor and light sensors," IEEE Trans. Consum. Electron., vol. 54, no. 3, pp. 1173–1176, Aug. 2008
6. M. Moghavvemi and L. C. Seng, "Pyroelectric infrared sensor for intruder detection," in Proc. IEEE Region 10 Conf. (TENCON 2004), Nov. 2004, vol. 4, pp. 656–659
7. B. C. Hydro, Automatic Lighting Control for Energy Savings, Guides to Energy Management", 1990
8. K. M. Yanev, A. I. Litchev, and P. Van Otten, "Automatic Light Control for Efficient, Domestic Use of Energy", pp. 71 – 75, 2003
9. Kuntinan Plathong, Boonprasert Surakratanasakul, "A study of integration Internet of Things with health level 7 protocol for real-time healthcare monitoring by using cloud computing", Biomedical Engineering International Conference (BMEiCON) 2017 10th, pp. 1-5
10. Héctor Jalil Desirena Lopez, Mario Siller, and Iván Huerta. 2017. Internet of vehicles: Cloud and fog computing approaches. In Service Operations and Logistics, and Informatics (SOLI), 2017 IEEE International Conference on. IEEE, 211–216
11. Ishan Krishna, K. Lavanya. "Intelligent Home Automation System using BitVoicer", 2017 11th International Conference on Intelligent Systems and Control (ISCO)
12. Shreyas Ramachandran Srinivasan, Soorya Sridhar, Ganeshaanand Balasubramanian, Kaviarasan Vasu. "Complex Animal Movement Capture and Live Transmission (CAMCALT)", TENCON 2018 - IEEE Region 10 Conference
13. Vaibhav Oza, Pranav Mehta. "Arduino Robotic Hand: Survey Paper" , 2018 International Conference on Smart City and Emerging Technology (ICSCET), 2018
14. Sanchez, Gustavo A., and Gonzalez O. Carlos. "A low-cost control system for hydraulic applications", 2010 IEEE ANDESCON

AUTHORS PROFILE



Dr. A. P. Nirmala, MCA, M.Phil., Ph. D(CS) working as Associate Professor in the Department of MCA, New Horizon College of Engineering, Bangalore. She has 17+ years of teaching experience. She has published 20 research papers in National and International Journals. Her research areas include Cloud Computing, Virtualization and Cyber Security.



Prasenjit Kumar Das pursuing PG degree in the department of MCA, New Horizon College of Engineering, Bangalore. He has published 1 research paper in National Journal and presented 1 research paper in National Conference.