

Placemento – An Android based Project for the Automation of Placement and Training Department

Akash Srivastava, Annu Malik, Alisha Bhatt, Aprajita Kumari, Prof. Manju More E

Abstract: Training and Placement department is one of the important area to any educational Institute, even in this era, we are doing most of the work by using human interventions. The main aim of this paper is to automate the Training and Placement cell of Reva University. The main feature of this project is the generation, verification, authentication and easy analysis with maintenance of relevant data. This is achieved by means of modern Technology like Android and database servers. This will provide the facility to maintaining student data along with placement records of the college. This will serve as a medium of free communication and feedback between the students and the placement department. The Planner in the application will help all the users to select what they want to study and, plan their day accordingly. All the syllabus and faculties will be one touch away from the users. Users can post their queries and can be in direct touch with the Training and placement cell. The project aims to provide maximum optimization and security along with minimal manual work. This will be helpful in efficient and better management of all placement and Training activities on campus. With the development of this project, the University can maintain computerized records without redundant entries.

I. INTRODUCTION

The use of smartphones and Internet has changed the accessibility of data to the user. Users can get more than enough information to use it easily and mold it to the desired output or observation.

A. Training and Placement

This paper is about the automation of T&P Team. This app for our college is very crucial for students and the placement department to collaborate with one another. **Placemento can be used to** help our students to submit their profiles to the training and placement cell [1] of the Institute. They can create, update their respective profiles get to know about the companies coming for on campus/off campus/pool campus/group pool categories of campus interviews. Under this system all the students can improve their skill set,

Revised Manuscript Received on April 24, 2019.

Akash Srivastava, School of C & IT, REVA University, Bengaluru, India.
Annu Malik, School of C & IT, REVA University, Bengaluru, India.
Alisha Bhatt, School of C & IT, REVA University, Bengaluru, India.
Aprajita Kumari, School of C & IT, REVA University, Bengaluru, India.
Manju More E, School of C & IT, REVA University, Bengaluru, India.

consume relevant information that will help them in being successfully placed.

The training and placement cell can easily contact or update the students of the recent information. Students can also send their feedbacks or can post their queries on regular basis. The system holds together the database and the interface making it extremely easy for users to use it. No prior technology experience is required to use the app. This system is accessible by students as well as an admin.

B. Existing Systems

The existing placement cell procedures and undertakings are very tedious and time consuming. Involvement of human resources leads to so many analytical problems. These errors lead to huge maintenance problems and student downfall due to system errors. Manual work makes the documentation and sorting very difficult. These analytical procedures lead to complex management and high analytical costs, which makes the system expensive and uneconomical.

C. Proposed System

In this modern time everyone wishes to be employable after completion of their graduation. For simplicity of these hectic procedures we propose Our App “**Placemento**”, is used to minimize the manual intervention and eliminate redundant and unnecessary data. **Placemento** helps in fast access, which will enable to upload their verified personal details and educational information. The students who are interested in placements will register using their email IDs. The Application procedure in our app will have information about the companies visiting our college and interested students, after going through it, They have to successfully clear a quiz[10]. Then they are supposed to fill in all the required credentials and apply for placement. Our app also has an anonymous feedback and voting where the students can give their opinions and suggest changes for better operation of the placement activities.

D. Motivation

We are developing this app for the university to avoid the manual process and make the automated process faster and secure[9]. Training and placement procedures are complex and involve a tiresome task of filing papers repetitively. Students have to run to the placement cell when they need

some information about the companies or placements. It is very difficult for the students to communicate with placement trainers, as there is no well-established platform. So, we intend to give a greener solution by means of this development of APP, by providing the necessary information within a click.

II. RELATED WORK

A. College Collaboration Portal with Training and Placement- Shilpa Hadkar, etal.

Registration were done by circulating the registration form to the students, which was a conventional way and used to take so much time and imprecise. There were many drawbacks like providing notifications, which was done by circulating it on noticeboard. To overcome this problem, online registration can be done by the students themselves. The notifications can be sent through Email and mobile SMS[8]. Even by using this method, the alumni data can be stored and could be easily accessed by the students if needed.

B. An Interactive Training and Placement System - Mr Nilesh Rathod, etal.

An Interactive Training and Placement (ITaP) System is used to automate the pursuit of placement cell. It is used to provide a scope for the students which will spring up the selection ratio and which is easily manageable and effortless. OP notifies the students regarding the various job opening; the students can upload their resume, it invites the students not only for placements but for other activities too, tracking the selection process which is communicated with the students participating for the same[13]. The Placement process of each and every drive is controlled individually. It Sends notifications regarding job openings, students profiles are authenticated and activated. It shortlists the students and send the information based upon each round which is given by HR Manager, resume of the shortlisted students are reverted back to the company HR manager. Selected students data is also saved separately. It manages student profile, considering the eligibility criteria preference of students are made, Time & Role Based Secured Access to users.

C. Design Paper on Online Training and Placement System (OTaP) - Prof. Seema Shah Assistant Professor, etal.

Online Training and Placement System (OTaP) is to signify the way through which users can upload and retrieve information. In OTaP majorly three types of users are there: administrator, student and recruiter. Most of the priorities are given to the Administrator (Master User). Updating and approval in such functions which are done by the Administrator. Administrator can view and approve the application forms[12]. Students can go through the details provided and can register according to their preference. The Recruiter will go through the details provided by students

and based upon the criteria, the recruiter can approve or reject the applications. OTaP system is cost effective which is used to automate the system. OTaP is also used in RGIT (Rajiv Gandhi Institute of Technology).

D. Enterprise Cooperation for The Benefit of Students, Enterprises and companies - Zirra E, etal.

Training and Placement cell are part of big institutes which train the students and help them to get into acknowledged organizations. This whole process if done manually includes a tiresome work which is time consuming. A net-based application is used to develop within the windows platform which can be used to automate Training and Placement Cell[14], fields in which the students are good at, can be collected for the further drive. User should login through the website application, TPO manages the data of college, related to the placement. Set of papers will be provided on this website with different genre like technical, reasoning etc., based upon the preference, students can take online examination and based upon the results of the examination the placement coordinator can offer there, some of the students from attending further drives. This system also automates the work like updating resume and credential which gives job alerts.

E. Training and Placement Web Portal - Mr Hitesh K, etal.

This proposed system is a web portal which is designed to manage data provided by training and placement cell. Our objective is to develop a system which will be used by placement department. The system will be used to advance the functionalities which will be performed for the activities of placement cell[17]. It has a modular architecture. Modules can be added or replaced based upon the requirement of the situation[21]. Training and Placement department can use this application to manage students' information. On contemporary basis few modules are implemented for managing the data of training and placement cell. There are more modules like: Adding student information, Information regarding the company and also provides study material regarding the company which the student will be attending.

F. A Survey on Android App for Training and Placement cell – Sanket. R, etal.

Training and Placement department is one of the major departments of any institute to help the students to get into any organization. The aim of the proposed system is to automate Placement and Training Cell of SRES College. This paper majorly focuses on the features like, Email generation and sending it to the user. The details of the user will be added to the system and based upon the criteria of the company notification, it will be sent to all eligible students[18]. It is user friendly, as the students can apply for any company by themselves, if they are

meeting all the eligibility criteria. The system saves all the required data of the students including the placement records. A communication wall is also provided through which students can ask their queries and it will be answered. This system will surely provide the maximum optimization, effortless, it also gives security. As it will be automated, the data will be secure and easily manageable by placement department[15].

G. Android Based Training and Placement Automation - TejashriGosavi, etal.

Conventionally in Placement department all the work is done manually which cannot be relied all the time. There are huge number of students, maintaining and managing the data of each and every student is tiresome and difficult task if done manually. TPO maintains the entire document and update it time to time which again takes lots of time. The proposed system can be used to overcome these kinds of drawbacks of present system, as it automates the work which is done by the placement cell. This system provides easy updating and retrieval of data. After opening this android application, the application will ask for login details, and if the user is new they can go for sign up page. After logging in, user can upload resume, resources are provided for reference as study material, feedback option is also given for the students. The system has three users: TPO faculty, students, Recruiter. The TPO handles all the updating and approval of the requests given by the students, which means it can view and approve the resumes. Students can register for the company if they match the eligibility criteria[19]. Students can also refer to the study material and set of question paper which will help them to understand how the placement process will be. Online forums are through which students can interact with TPO or other students. Shortlisted students get notification with the help of this system.

III. METHODOLOGY

In the existing system all the processes like registration and applying for placements were done manually which had the following drawbacks:

- **Lack of Credible Data:** Absence of credible and timely data causes a lack of reliable reference points in the system.
- **More man power:** leads to more expenses as more man power leads to large requirements making the procedures uneconomical. More human involvement also makes the process slow and more inefficient.
- **Time consuming:** The existing systems are more complex leading to additional workload and more human involvement.
- **Large volume of paperwork:** Manual processes include lots of paper work making it more complex and difficult to document.

- **Analytical expense:** All the existing systems do not fully comply with the analytical expenses. All the human resources need maintenance charge and require more time to carry out tasks. All these leads to high expenses.
- **Tedious:** All the existing systems are very tedious and complex, thus is required to be modified.

The aim of the proposed system is to develop a system with overshadow, integrate facilities which can overcome the limitations of the existing system. Some of the advantages of the proposed system are:

- **Data Security:** Data will be more secured and will be accessible to only the authorized users.
- **Minimal manual work:** The proposed system offers minimal human work, as all the work is by the system itself.
- **Greater efficiency:** The system is more efficient in terms of both time and space. It will offer number of functionality through a single module.
- **Minimal Operation time:** As all the modules are interlinked and dependent leading to a faster and more reliable transfer of data among the modules.
- **Ensure accuracy of data:** No manual intervention is required with respect to the data. So, no chance of data inaccuracy.
- **Innovative quiz:** Students are compelled to learn about the company through an innovative quiz regarding the company[23].
- **Easy interaction with placement officers:** Students can easily be in touch with the placement officers. They can provide feedback and can also post queries to the placement officer being the Admin.
- **Easy to access and edit the profiles:** Being an interactive system it avails users with various interesting services including editing and omitting.

Placemento describes the solution for problem which exists in the current system. The major problem in existing manual system is constant retrieval and updating of the student data. The proposed system provides automation in all the processes like registration, updating, and sorting of the student data. Also if the student is eligible for company, then the student can directly apply for the company and can also search for good companies by a single click[20]. This paper describes the idea about the users and their convenience. This makes the system more attractive and more dependable. There are mainly two users: Administrator and student. The admin is the most authorized user. Admin has the more number of services than the other users. The different functions involved are



Notification, call for tests and approval. Students can register and can view their profile details. This app also describes the idea of automated anonymous voting and feedback system [3].

In **Placement**, the TPO gives information about upcoming placement drives or activities so that students can prepare for the same [4]. This app can also be used by the Training and Placement coordinators of the college to manage the student information, analyze frequent patterns and extract useful information. Students logging in will be able to upload their information. The key feature of this paper is that it is onetime registration and allows feedback and anonymous voting. The application provides the facility of maintenance of student details. To reduce the tedious task of managing the student information [5] and of various recruiters, a new system is planned and implemented. We provide an innovative quiz driven process of applying for placements and also the TPO can conduct ADT's (Aptitude Development Tests) [6].

IV. SYSTEM OVERVIEW

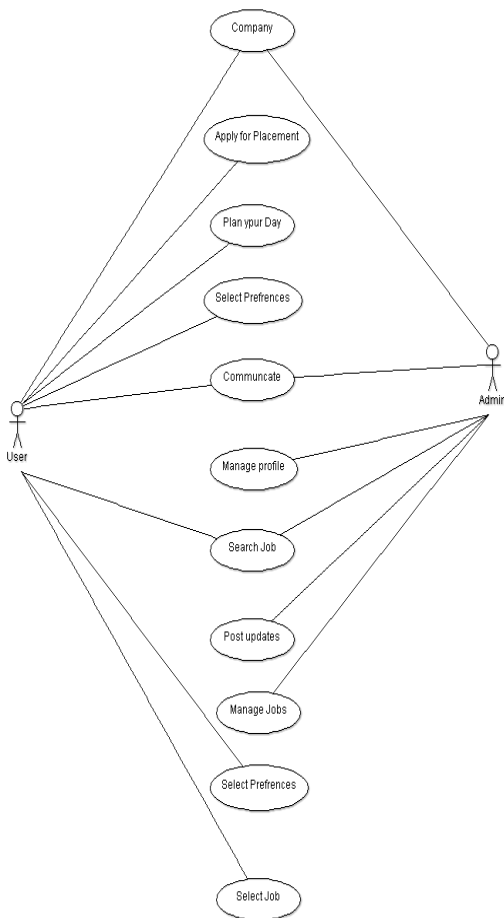

Figure1. Use case diagram

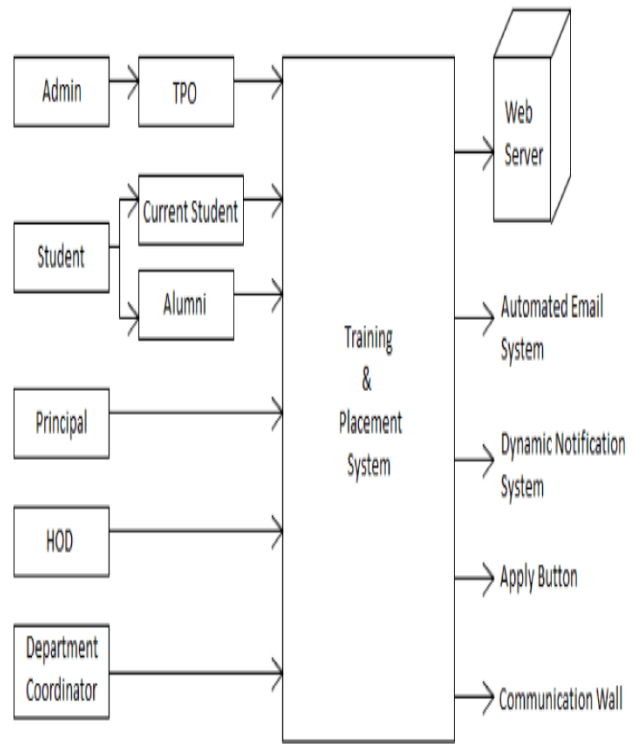

Figure 2. System overview.

The whole system is comprised of multiple modules which are interlinked to provide the desired results. The Training and placement system is accessible through multiple modules. The behavior of the system varies based on the module by which it is accessed. Then the system reacts to the module accordingly and the user can use the preferred service. The system provides multiple services as mentioned in fig (2). All the modules are interlinked using a web server which will monitor and regulate the flow of data in the system. The redundancy of data is avoided, using the same server for all the modules. As the modules are separate, failure of any module will not affect the functionality of other modules. The system security and bandwidth is variable and can be varied as and when required. It also provides flexibility as any number of modules can be added and thus is open to future up gradations.

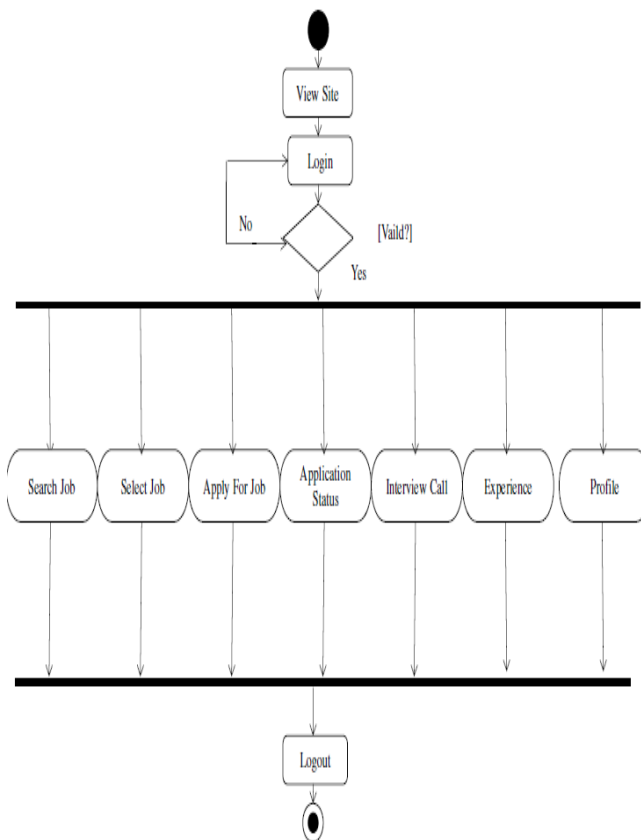

Figure 3. User Activity Diagram

V. OBJECTIVES

- **Reduced paperwork:** Automation provides us with luxury of reduced manual work. Hence, leading to reduced paperwork and complexity.
- **Reduced operational time:** As all the modules are interlinked and dependent leading to a faster and more reliable transfer of data among the modules
- **Active interface:** The ease with which the system can be used invites more users and makes the usability quite simple and tempting.
- **User friendly interface:** The system being easy to use, requires no assistance. Users can very easily access all the modules and services to wish to use.
- **Easy to create and update profiles:** A separate module has been provided to edit and omit the information. This makes the data more flexible and more secure.
- **Student preparedness for industry employment** :students are made aware with all the important subjects[11]. Industry grade materials are accessible through the system which makes them prepare for the industry level scenarios.

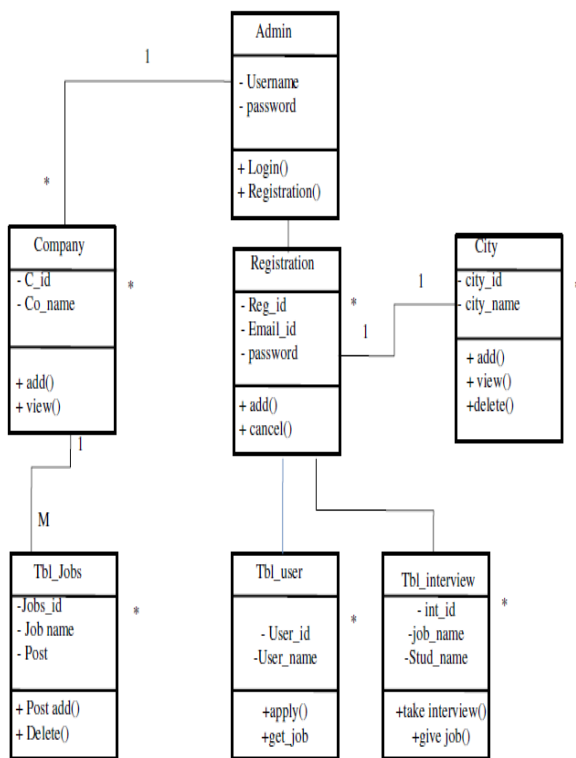
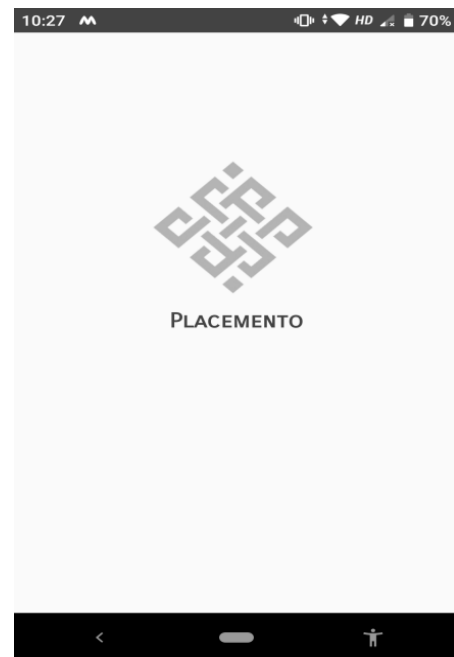

Figure 4. Class Diagram.

VI. RESULTS AND DISCUSSION



Splash screen provides an introduction to the user regarding the app, the name and the logo. The logo holds up for 4

seconds and leads to the next template.

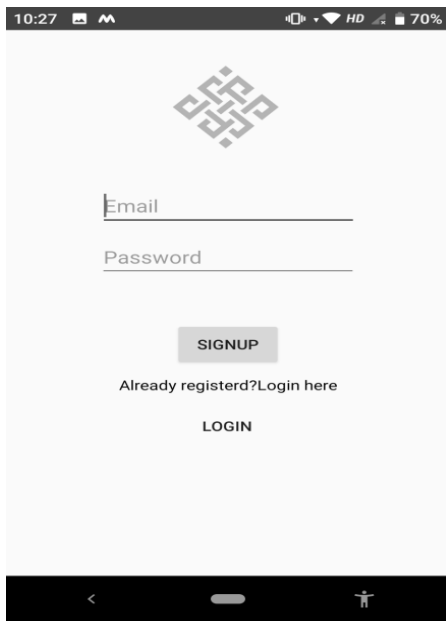

This is the login template where the user provides the authenticated credentials to login in the app. Any new user can sign up and make their account by providing the required credentials.

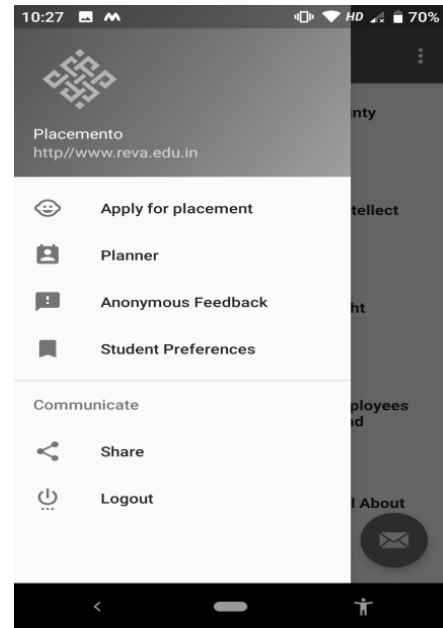

We have provided a navigation bar over our timeline template, allowing users navigate through various modules in the app. The bar provides all the services directly or indirectly accessible by an authenticated user.

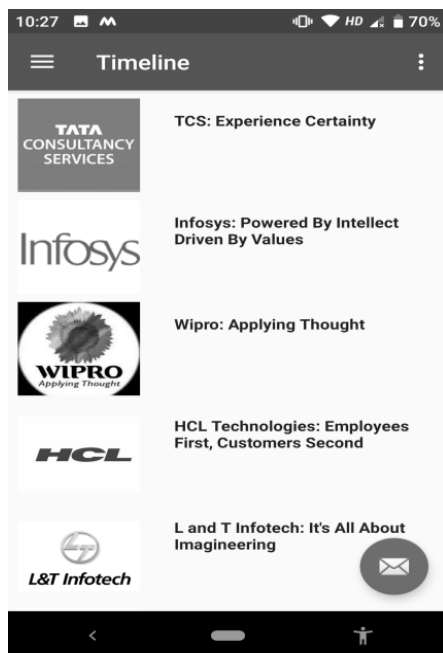

This is the app timeline template. It consists of all the important information with respect to user. All the fragments are dynamically posted and vary according to the requirements of the user. The timeline can also be controlled by the admin who can upload all the important notices to all the users collectively.

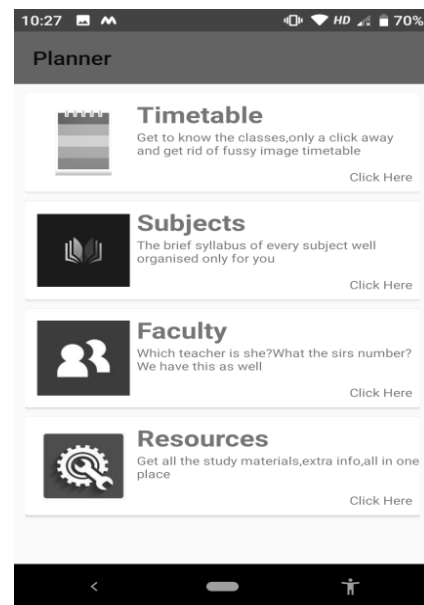

The timetable module will help the students plan their day accordingly after they have mentioned their preferences. The module will also help them with all the subjects and the faculty's contact info with whom they can concern with if, any doubt is encountered[22].

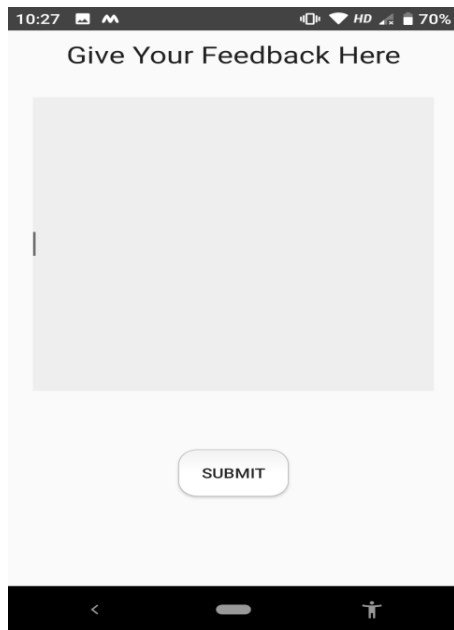

This template will allow the users to be in touch with the placement officers as all their responses will be recorded and will be entertained by the placement department. Students can also post their queries or any doubts regarding the usage of the app.

VII. CONCLUSION AND FUTURE SCOPE

As the technology is growing at a faster rate, the usage of manual system is near extinct. Our app satisfies the needs to run the processes of placement in a smooth and quick manner[24]. The students can edit their profile and there will be security of data. This app will prove to be a powerful tool in satisfying the requirements and functionality of the university.

The following functionalities can be incorporated for the betterment of the app also to help the students in a much more comprehensive manner:

- **Resume building:** Students can make their own resumes selecting from the various templates. It can also be saved offline or downloaded for which most of the websites charge money.
- **Linking to University server for better efficiency:** The services and the cloud of the university allows the users to be in complete touch with the Placement and Training department.
- **Aptitude test:** Students need not to search on various websites for aptitude preparation and evaluation[16]. System will avail them with a separate module to practice and evaluate them.
- **Tutorial Sessions:** Different tutorials and remedial substitutes can be added into the system, making it a fully capable and functional Android app.

VIII. REFERENCES

- [1] Ms. Shilpa Hadkar, Snehal Baing, Trupti Harer, Sonam Wankhade, K.T.V. Reddy, "College Collaboration Portal with Training and residency", IOSR Journal of Computer Engineering (IOSR-JCE), Volume 10, Issue 2 (Mar. - Apr. 2013), PP 79-81.
- [2] Nilesh Bhad, Pooja Kamble, Sunita Saini, Prof. Yogesh Thorat, "An Interactive Online Training and Placement System", International Journal of Advanced Research Development, Vol. 3, Issue 11, 2016.
- [3] Prof. Seema Shah Assistant Professor, Mr Nilesh Rathod, "Design Paper on Online Training and Placement System (OTaP)", International Conference on education and Educational Technologies, 2013
- [4] Zirra E., March F., Building University - "Enterprise Cooperation for the Benefit of Students, Enterprises and Companies", EU-Net workshop, 2006.
- [5] Mr Hitesh K. Kasture, "Training and Placement web Portal", International Journal on Recent and modernization. Trends in Computing and Communication, Volume: 2 Issue: 3, 586 – 591.
- [6] Android app "Placement Aptitude and Interview".
- [7] IJARIIE "A Survey on Android App for Training and Placement Cell"- Sanket. R. Brahmkar, Rahul. S. Ghule, Shubham. K. Chavan, Landge. D. Ashish, Pavan. D. Borse, volume 1.
- [8] MJRET "Android Based Training And Placement Automation"- Tejashri Gosavi, Shraddha Gaikwad, Rohit Nazirkar, Amol Salke Department of Computer Engineering, JSPM's ICOER, Wagholi, Pune, India. MC4-3-2015 MJRET-ISSN: 2348-6953.
- [9] K.G. Patel, C. K. Patil, "Study of Implementation of Placement System", International Conference on emerging trends in engineering and management research, 23rd march 2016
- [10] Talaba, D., Moja, A., Zirra, E., Guidelines towards a European standard for quality assurance of student placement, available in login space on www.q-planet.org.
- [11] Tynjälä, P., Perspective into learning at the workplace, Educational Research Review, 3, 2008, pp.130-154.
- [12] Swati Choudhary, Monica Landge, Shital Salunke, Swarupata Sutar, Kirti M hamunkar, "Advanced training and Placement Web Portal", International Journal of Technical Research and Applications e-ISSN: 2320-8163, www.ijtra.com Volume 4, Issue 2 (March-April, 2016), PP. 75-77.
- [13] Mr R J LAIRD, "Interactive Web-based Placement Management-Principles and Practice using OPUS", School of Engineering, University of Ulster, Shore Road, NEWTOWNABBEY, Co. Antrim, UK, BT37 0QB, 2008.
- [14] Ashwajit Ramteke, Mrunal Deogade, Prafull Deogade (2015), "Student Automation System for placement Cell", IORD journal of Science & Technology, Volume 2, jan-feb 2015, pp 104-109.
- [15] Prof. P. V. Phadke, Miss. T. D. Marodkar & Miss. N. A. Chunade, "Training and Placement Office Automation System", Imperial Journal of Interdisciplinary Research (IJIR) Vol-2, Issue-6, 2016.
- [16] Laird, R. J., & Turner, C. R. (2008a, September). 'Placement assessment online using OPUS – the work based assessors' views. Paper presented at ASET Annual Conference, Plymouth, UK.
- [17] A. Arjuna Rao, K. Sujatha, V. Bhagyashree, B. Dileep Kumar, "Automation of Training and Placement Cell", International Journal of Engineering Research and General Science Volume 4, Issue 3, May-June, 2016 ISSN 2091-2730.
- [18] Neha Choudhary, Sahil Nagrare, Shrikant Kale, Akshay Sontakke, Prof. Piyooosh Awthare, "Training and Placement Guru", International



[19] Praveen Rani, Dr. Rajan Vohra, " *Generating Placement Intelligence in Higher Education Using Data Mining*", International Journal of Computer Science and Information Technologies, Vol. 6 (3), 2015, 2298-2302.

[20] Ms. Taheniyath Shua, Ms. Shubhangi Chikte, Ms. Priya Sakharkar, Ms. Seema Bundele, Ms. Nikita Wankar, Prof. S. R. Sontakke, " *An Automated Solution to Training and Placement Cell Activities*", International Journal on Recent and Innovation Trends in Computing and Communication ISSN: 2321-8169 Volume: 5 Issue: 4 .

[21] Vikrant A Agaskar, Surjit H Singh, Srujan S Chaudhari, Keyur P Rajyaguru, " *To Automate Entire Placement and Training Cell for The College using Android Application with Cloud Computing*", International Journal of Advanced Research in Computer and Communication Engineering Vol. 5, Issue 3, March 2016.

[22] S. R. Bharama goudar, Geeta R.B., S.G. Totad , " *Web Based Student information Management System*", International Journal of Advanced Research in Computer and Communication Engineering Vol. 2, Issue 6, June 2013.

[23] T. Jeevalatha, N. Ananthi, D. Saravana Kumar, " *Performance Analysis of undergraduate student's placement selection using decision tree algorithms*". International Journal of Computer Applications, Vol.108-No 15, December 2014.

[24] Dr. S.B. Vanjale, Rahul Kumar Modi, Supreet Raj, Akshit Jain, " *Smart Training & Placement System*", IJCST Vol. 8, Issue 2, April - June 2017.

AUTHORS PROFILE



Akash Srivastava, Student at REVA University, Bengaluru, India. Pursuing my 8th semester of B-tech in Computer Science and Engineering.



Annu Malik, Student at REVA University, Bengaluru, India. Pursuing my 8th semester of B-tech in Computer Science and Engineering.



Alisha Bhatt, Student at REVA University, Bengaluru, India. Pursuing my 8th semester of B-tech in Computer Science and Engineering.



Aprajita Kumari, Student at REVA University, Bengaluru, India. Pursuing my 8th semester of B-tech in Computer Science and Engineering.



Prof. Manju More E, Assistant Professor at REVA University, Bengaluru, India.