

Iterative Channel Estimation and ICI Cancellation Techniques in MIMO-OFDM Wireless Communication Systems

Ragam.Gouthami, K.Ragini, Ch. Ganapathy Reddy

Abstract- A multiple-input multiple-output (MIMO) communication system combined with the orthogonal frequency division multiplexing (OFDM) modulation technique can achieve reliable high data rate transmission over a broadband wireless channel. A main challenge in wireless communication is retrieval of the channel state information and ICI cancellation. The channel estimation and ICI cancellation is estimated with the help of Iterative turbo channel estimation, Iterative pilot assisted channel estimation and ICI Cancellation techniques.

Keywords- (MIMO), (OFDM), ICI

I. INTRODUCTION

FOURTH Generation Mobile system (4G) has very good features than previous generation networks such as 2G & 3G. The growing demand of multimedia services and the growth of Internet related contents lead to increasing interest to high speed communications. The requirement for wide bandwidth and flexibility imposes the use of efficient transmission methods that would fit to the characteristics of wideband channels especially in wireless environment where the channel estimation is very challenging [1].

In wireless environment the signal is propagating from the transmitter to the receiver along number of different paths, collectively referred as multipath. While propagating the signal power drops of due to three effects: path loss, macroscopic fading and microscopic fading. Fading of the signal can be mitigated by different diversity techniques. To obtain diversity, the signal is transmitted through multiple (ideally) independent fading paths. E.g. in time, frequency or space and combined constructively at the receiver. Multiple Input- Multiple-Output (MIMO) exploits spatial diversity by having several transmit and receive antennas. However, in this paper "MIMO principles" assumed frequency flat fading MIMO channels.

II. OFDM

2.1 Overview of OFDM

Orthogonal Frequency Division Multiplexing (OFDM) is a multicarrier transmission technique, many carriers, each one being modulated by a low rate data stream share the transmission bandwidth.

OFDM is similar to FDMA in that the multiple user access is achieved by subdividing the available bandwidth into multiple channels that are then allocated to users. However, OFDM uses the spectrum much more efficiently by spacing the channels much closer. This is achieved by making all the carriers orthogonal to one another, preventing interference between the closely spaced carriers [5]. This scheme is mostly used in various applications such as digital TV & audio broadcasting, wireless LANs, Wi-Fi, WiMAX, LTE, ultra-wideband (UMB) systems.

The data is split into various parallel data streams or channels, one for each sub-carrier. Each sub-carrier is modulated by digital modulation techniques such as Quadrature Amplitude Modulation (QAM) or Quadrature phase-shift keying (QPSK) at a low symbol rate, maintaining total data rates similar to conventional single-carrier modulation schemes in the same bandwidth.

The orthogonality of the carriers means that each carrier has an integer number of cycles over a symbol period. Due to this, the spectrum of each carrier has a null at the location of each of the other carriers in the system. This results in no interference between the carriers, allowing them to be as close as theoretically possible. This overcomes the problem of overhead carrier spacing required in FDMA. Each carrier in an OFDM signal has a very narrow bandwidth (i.e. 1kHz), thus the resulting symbol rate is low. This results in the signal having a high tolerance to multipath delay spread, as the delay spread must be very long to cause significant inter-symbol interference (E.g. $\approx 500 \mu\text{sec}$) [2].

2.2 MIMO

High transmission data rate, spectral efficiency and reliability are necessary for future wireless communications systems. Unlike Gaussian channels, wireless channels suffer from attenuation due to multipath in the channel. Multiple copies of a single transmission arrive at the receiver at slightly different times. Without diversity techniques a severe attenuation makes, difficult for the receiver to determine the transmitted signal. Diversity techniques provide potentially less-attenuated replica of the transmitted signal at the receiver [5].

Multiple-Input Multiple-Output (MIMO) antenna systems are a form of spatial diversity. In a multipath-rich wireless channel, deploying multiple antennas, at both the transmitter and receiver, achieve high data rate without increasing the total transmission power or bandwidth.

Additionally, the use of multiple antennas at both the transmitter and receiver provides significant increase in capacity.

Manuscript published on 30 August 2013.

* Correspondence Author (s)

Ragam. Gouthami, G. Narayanamma Institute of Technology & Science, JNTU, Hyderabad, Andhra Pradesh, India

Dr.K. Ragini, G. Narayanamma Institute of Technology & Science, JNTU, Hyderabad, Andhra Pradesh

Ch. Ganapathy Reddy, G. Narayanamma Institute of Technology & Science, JNTU, Hyderabad, Andhra Pradesh

© The Authors. Published by Blue Eyes Intelligence Engineering and Sciences Publication (BEIESP). This is an [open access](http://creativecommons.org/licenses/by-nc-nd/4.0/) article under the CC-BY-NC-ND license <http://creativecommons.org/licenses/by-nc-nd/4.0/>.

MIMO system may be implemented in a number of different ways to obtain either a diversity gain to combat signal fading or to obtain a capacity gain.

Generally there are three categories of MIMO techniques. The first aim is to improve the power efficiency by maximizing spatial diversity. The second is the layer approach to increase capacity. Third type exploits the knowledge of channel at the transmitter.

2.3 MIMO-OFDM

MIMO-OFDM (multiple input multiple output orthogonal frequency division multiplexing), a new wireless broadband technology, has gained great popularity for its capability of high rate transmission and its robustness against multi-path fading and other channel impairments. The arrangement of multiple antennas at the transition end and reception end results increase in the diversity gain refers the quality of signal and multiplexing gain refers the transmission capacity.

MIMO-OFDM transmitter consists of OFDM transmitters, in which the incoming bits are multiplexed, and then, each branch in parallel performs encoding, interleaving, QAM mapping, and N -point Inverse Discrete Fourier Transformation (IDFT) and adds a cyclic.

The receiver first estimate and correct for the frequency offset and the symbol timing, e.g., by using the training symbols in the preamble. After the channel, the cyclic extension is removed as it just contains the channel spread. Then the N -point Discrete Fourier Transformation (DFT) is performed per receiver branch. Each antenna receives a different noisy superimposition of the faded versions of the N transmitted signals [6].

2.4 CHANNEL ESTIMATION

The wireless channel in mobile radio poses a great challenge as a medium for reliable high speed communications. When a radio signal is transmitted through a wireless channel, it suffers various types of distortions. Hence, the receiver obtains a linear superposition of the signals transmitted by all the users, attenuated by arbitrary factors and delayed by an arbitrary amount. In addition, due to scattering and reflections from various obstacles between the transmitter and the receiver, multiple copies of the same signal reach the receiver. The channel variation becomes more significant in both time and frequency domain as mobility increases.

In an ideal radio channel, the received signal would consist of only a single direct path signal, which would be a perfect reconstruction of the transmitted signal. However, in a real channel the signal is modified during transmission. The received signal consists of a combination of attenuated, reflected, refracted, and diffracted replicas of the transmitted signal. On top of all this, the channel adds noise to the signal and can cause a shift in the carrier frequency if either of the transmitter or receiver is moving (Doppler Effect). Understanding of these effects on the signal is important because the performance of a radio system is dependent on the radio channel characteristics.

2.5 CHANNEL ESTIMATION AND ICI CANCELLATION ALGORITHMS

Zhao M et al, have proposed (August, 2008), a novel procedure which makes use of preamble, pilots and soft decoded data information to track the channel frequency response in every OFDM symbol within the data packet or data frame. Three-stage estimation scheme is proposed to reduce the complexity and adapt the channel estimates with respect to the feedback information. More precisely,

estimate the channel based on the improving a priori information of the decoded data, preamble and the pilots by adaptively weighting the statistics according to the respective levels of reliability.

A novel iterative channel estimation method with three distinctive operation stages, namely initial coarse estimation stage, iterative estimation stage, and a final estimation stage. Initial coarse estimation stage is performed at the first iteration. In the iterative estimation stage, LS estimation is first performed for both pilot and data subcarriers, followed by frequency-domain combining and time-domain combining, Similar to the pilot tones.

The final estimation stage is performed on the final iteration, where the decoding information from MAP decoder becomes very reliable, and can serve almost as good as reference signals.

The advantage is, makes use of preamble, pilots, and soft, decode/data in an iterative fashion to improve the system performance over the time and frequency selective channel while maintaining the system throughput. The Doppler spread information is utilized for computing the frequency – a time domain channel correlations in the channel estimation process. The channel estimation method does not exploit the data symbol estimates.

Diggavi Suhas (August, 2002) has proposed a technique. The main advantage of Orthogonal Frequency Division Multiplexing (OFDM) transmission in time-invariant channels is due to the fact that, the Fourier basis forms an eigenbasis for time-invariant channels, simplifies the receiver OFDM schemes. [7].

The impact of time-variations with in a transmission block which could arise both from the Doppler spread of the channel and from the synchronization errors. The time domain ICI mitigation algorithm reduces the ICI between the subcarriers, develop a data model for ICI.

Cyclic prefix of length equal to the channel memory is inserted in each input block to eliminate Inter-Block Interference (IBI). Estimation of the time domain channel coefficients is performed by using pilot tones and by linear interpolation of the time domain channel estimates.

The disadvantage is, block time-invariance assumption may not be valid in high-mobility applications or when there are impairments such as synchronization errors.

Hardjawana W, et al (May, 2010) has proposed a technique uses comb type pilot arrangement as a pilot tones need to be placed in each OFDM symbols in order to estimate its wireless channel coefficients .The iterative receiver combines pilot –assisted channel estimation, ICI Cancellation and decoding [4].

In the pilot channel estimation the time domain channel coefficients are estimated using pilot tones .Time domain interpolation and least square method is applied to estimate the pilot tones. After obtaining the channel estimates ICI cancellation and decoding is to be performed. In each iteration ICI caused by Doppler shift is subtracted from the each receiver sub-carrier.

Interference from the various transmit antennas is suppressed by a Parallel Interference Cancellation (PIC) and Decision Statistics Combining (DSC) technique. The decision statistics of each stage are updated by soft outputs generated from the decoders.

The ICI cancellation and decoding are performed iteratively a number of times. Once the process is completed, the decoder soft outputs of the transmitted data symbols are fed back to the channel estimator and treated as additional known pilot symbols to assist with the channel estimation. Channel estimates are refined iteratively by using both the decoded data and pilots in the iterative channel estimation.

The main disadvantage is, does not consider the Doppler spread information in to account in the channel estimation process.

A new iterative channel estimation and ICI cancellation scheme for MIMO-OFDM systems. The proposed scheme simultaneously utilizes the Doppler spread information and the iterative estimates of data symbols in the channel estimation process. Here, assumed that the pilot symbols are placed in each OFDM symbol, in equispaced groups (i.e., the groups of pilot symbols are uniformly partitioned on the OFDM symbol), to help with the channel estimation [3].

Time-domain channel coefficient is approximated by weighted time-domain channel interpolation. A set of time-domain channel coefficients that will be used for the channel estimation process. These selected channel coefficients as time domain markers. Then, for the rest of the channel coefficients, each channel coefficient is approximated by interpolating two selected time-domain markers. These two time-domain markers are chosen in a way that they have maximum correlation with the respective channel coefficient.

The interpolation weight design of these markers takes into consideration the Doppler spread information at the receiver. The time-domain markers are estimated by using a Least-Square (LS) method. Once all the channel coefficients are obtained, the estimate of ICI, which is caused by the Doppler spread, is subtracted from the received signal by a Parallel Interference Cancellation (PIC) module. The outputs of the PIC module are then passed to the Decision Statistical Combining (DSC) module, where the decision statistics signal is obtained by recursively combining its values in the current and previous iterations.

A MIMO-OFDM system with M_T transmit and M_R receive antennas. The block diagram of a MIMO-OFDM system transmitter is shown in Fig. 1. At the transmitter side, a serial bit stream is mapped to a symbol stream by a modulator. Then, this serial symbol stream is converted into parallel sub streams. Next, pilot symbols for the channel estimation are inserted into these parallel sub streams, in the frequency-domain, prior to the OFDM modulation. The OFDM modulation is then implemented by performing inverse discrete Fourier transform (IDFT). Each transmits antenna sends independent OFDM symbols. Let $X_p(k)$ denote the information symbol sent by transmit antenna p at subcarrier k . The OFDM symbols transmitted by M_T transmit antennas can then be presented as

$$X = [X_1, \dots, X_p, \dots, X_{M_T}]^T \dots \dots \dots (1)$$

Where $X_p = [X_p(0), \dots, X_p(N-1)]^T$ is the OFDM symbol transmitted from the p^{th} transmit antenna, and N is the number of subcarrier for one OFDM symbol. After performing inverse DFT (IDFT) on each transmit antenna, the time-domain modulated signal on the p^{th} transmit antenna can be expressed as $x_p = F^H X_p = [x_p(0), \dots, x_p(N-1)]^T \dots \dots \dots (2)$, where F is the $N \times N$ DFT matrix with its element at row n and column k , which is defined as $w_{n,k} := e^{(j2\pi nk/N)}$, for $n, k=0, \dots, N-1$.

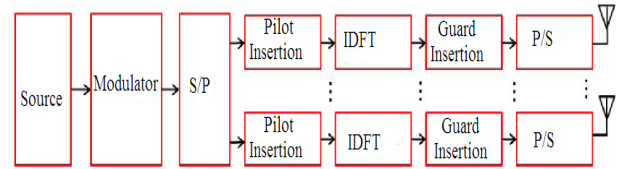

Fig: 1 OFDM Transmitter Structure

Inter Symbol Interference (ISI) is caused due to a multipath delay spread, this effect is eliminated by a cyclic prefix of length equal or greater than the expected maximum time delay of the channel is inserted in each OFDM symbol prior to transmission. This prefix serves as guard interval (GI) between OFDM symbols. Finally, the symbol streams are converted from a parallel to a serial form and allocated to corresponding transmitters for transmission. The block diagram of a MIMO-OFDM system receiver is shown in Fig. 2. At the receiver side, once the GI is removed, the received signal at the q^{th} receive antenna and time n can be represented as

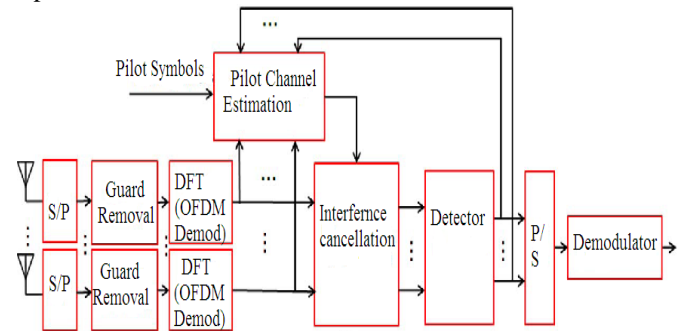

Fig: 2 Receiver Structure of PIC-DSC Interference cancellation techniques

$$r_q(n) = \sum_{p=1}^{M_T} (h_{p,q}(l, n) \otimes x_p(n)) + w_q(n)$$

$$= \sum_{p=1}^{M_T} \sum_{l=0}^{L-1} h_{p,q}(l, n) x_p(n-l) + w_q(n) \dots \dots \dots (3)$$

Where \otimes is the cyclic convolution, $w_q(n)$ is the additive white Gaussian noise (AWGN), and $h_{p,q}(l, n)$ is the impulse response of the l^{th} channel tap between the p^{th} transmit antenna and the q^{th} receive antenna at time n . Furthermore, the time domain channel matrix between the p^{th} transmit antenna and the q^{th} receive antenna, including the effects of the cyclic prefix (or GI), can be represented as (4). After performing the DFT on the received signal in (3), the symbol for the q^{th} receive antenna and the k^{th} subcarrier can be expressed as

$$C_{p,q} = \begin{bmatrix} h_{p,q}(0,0) & 0 & \dots & h_{p,q}(2,0) & h_{p,q}(1,0) \\ h_{p,q}(1,1) & h_{p,q}(0,1) & \dots & h_{p,q}(3,1) & h_{p,q}(2,1) \\ \vdots & \vdots & \ddots & \vdots & \vdots \\ 0 & 0 & \dots & h_{p,q}(0,N-2) & 0 \\ 0 & 0 & \dots & h_{p,q}(1,N-1) & h_{p,q}(0,N-1) \end{bmatrix}$$

$$R_q(k) = \sum_{p=1}^{M_T} \sum_{m=0}^{N-1} \sum_{l=0}^{L-1} H_l^{p,q}(k-m)w_{l,m}X_p(m) + W_q(k) \dots (5)$$

Where $W_q(k)$ the DFT is noise, and $H_l^{p,q}(k)$ denotes the IDFT of time-varying frequency-selective channel $h_{p,q}(l, n)$ i.e.

$$H_l^{p,q}(k) = \frac{1}{N} \sum_{n=0}^{N-1} h_{p,q}(l, n)e^{-\frac{j2\pi nk}{N}} \dots (6)$$

$R_q(k)$ Is the summation of the desired signal and original signal and ICI component.

$$R_q(k) = \sum_{p=1}^{M_T} H_l^{p,q}(0)w_{l,k}X_p(k) + \sum_{p=1}^{M_T} \sum_{m \neq k} \sum_{l=0}^{L-1} H_l^{p,q}(k-m)X_p(m)w_{l,m} + W_Q(k) \dots (7)$$

The channel is time variant during one OFDM symbol period the value of (5) would be non-zero only if $k=0$ ($\sum_{n=0}^{N-1} h_{p,q}(l, n)e^{-\frac{j2\pi nk}{N}} = 0$ for $k = 0, \dots, N-1$) under this condition, the ICI component in (6) disappears .however, if there is a non zero Doppler spread, this assumption is no longer true.

The received signal for all M_R receive antennas can be represented as

$$R = \mathcal{H}X + W \dots (8)$$

Where $R = [R_1, \dots, R_{M_R}]^T$ and $R_q =$

$[R_q(0), \dots, R_q(N-1)]^T$ is the received signal for the q_{th} receiver antenna,

$W = [W_1, \dots, W_{M_R}]^T$, \mathcal{H} is the effective channel matrix in the frequency domain, which is defined as

$$H = \begin{bmatrix} H_{1,1} & H_{2,1} \dots & H_{M_T, 1} \\ H_{1,2} & H_{2,2} \dots & H_{M_T, 2} \\ \dots & \dots & \dots \\ H_{1,M_R} & H_{2,M_R} \dots & H_{M_T, M_R} \end{bmatrix} \dots (9)$$

Here, the $(m, n)_{th}$ element of matrix $H_{p,q}$ is denoted as $\alpha_{m,n}^{p,q}$ and is defined as

$$\alpha_{m,n}^{p,q} = \sum_{l=0}^{L-1} H_l^{p,q}(n-m)w_{l,m} \dots (10)$$

$$0 \leq n; m \leq N-1$$

2.6 Selection of the Time-Domain Markers

$$h_n^{p,q} := [h_{p,q}(0, n), \dots, h_{p,q}(L-1, n)]^T, \quad 0 \leq n \leq N-1 \dots (11)$$

Where $h_n^{p,q}$ represents the non-zero elements of the n_{th} row in the time domain channel matrix $C_{p,q}$ has L non-zero elements.NL parameters are calculated to estimate the wireless channel in a time varying environment. This impacts the computational complexity of the receiver.

An interpolation is used between time-domain channel coefficients to reduce number of parameters for the channel

matrix. The time-domain matrix $C_{p,q}$ by utilizing a small number of its rows, which are denoted by M . Physically, this puts M markers in the time domain, where the channel coefficients are estimated. Then the channel coefficients at other times are interpolated by using the time-domain markers. This assumption will reduce the number of parameters to be estimated from NL to ML , where $M \ll N$.

$$h_{p,q}(l, n) = a_{l,n,p,q}^T [h_{p,q}(l, m(1), \dots, h_{p,q}(l, m(M))]^T \dots (12)$$

Where for $0 \leq l \leq L-1$

$$a_{l,n,p,q} = [a_{l,n,p,q}(m(1), \dots, a_{l,n,p,q}(m(M))]^T \dots (13)$$

2.7 Calculation of the Interpolation Weights

Interpolation weights are calculated based on the Doppler spread information. Calculation of interpolations weights by assuming correlation between $h_{p,q}(l, m)$ and $h_{p,q}(l, n)$ can be expressed as

$$D[m, n] := E [h_{p,q}(l, m)h_{p,q}^H(l, n)] \dots (14)$$

$$\check{h}_{n,p,q}(l) := [h_{p,q}(l, m(k), h_{p,q}(l, m(k'))] \dots (15)$$

As the set of time domain markers to represent $h_{p,q}(l, n)$ and

$$a_{l,n,p,q}^{NZ} := [a_{l,n,p,q}(m(k)), a_{l,n,p,q}(m(k'))]^T \dots (16)$$

As the non-zero elements of interpolation weights vector $a_{l,n,p,q}$ corresponding to the elements of $\check{h}_{n,p,q}(l)$. Then the set of non-zero interpolation weights $a_{l,n,p,q}^{NZ}$ that minimizes the channel estimation error defined as

$$E \left[\left| h_{p,q}(l, n) - a_{l,n,p,q}^{NZ} \check{h}_{n,p,q}(l) \right|^2 \right] \dots (17)$$

Can be obtained by orthogonality principal as

$$a_{l,n,p,q}^{NZ} \check{h}_{n,p,q}^H = R_{n,h,\check{h}}^{p,q} R_{n,h,\check{h}}^{p,q}^{-1} \dots (18)$$

where $R_{n,h,\check{h}}^{p,q} = E [h_{p,q}(l, n)\check{h}_{n,p,q}^H(l)]$ And

$$R_{n,h,\check{h}}^{p,q}^{-1} = E [\check{h}_{p,q}(l, n)\check{h}_{n,p,q}^H(l)]$$
 therefore, we will have

$$R_{n,h,\check{h}}^{p,q} = [D[m(k), d(m(k'), n)] \dots (19)$$

$$R_{n,h,\check{h}}^{p,q} = \begin{bmatrix} D[m(k), m(k)] & D[m(k), m(k')] \\ D[m(k'), m(k)] & D[m(k')m(k')] \end{bmatrix} \dots (20)$$

Consider two different types of wireless fading channels, i.e., Rayleigh and Rician fading channels. Assume that these channels follow Jakes' model and the model in, respectively. Therefore, the correlation between $h_{p,q}(l, m)$ and $h_{p,q}(l, n)$ for the Rayleigh fading channel can be expressed as

$$D[m, n] = J_0(2\pi f_d(m-n)T) \dots (21)$$

Where f_d and J_0 denote the Doppler spread and Bessel function of the first kind, respectively. However, for the Rician fading channel, the correlation between $h_{p,q}(l, m)$ and $h_{p,q}(l, n)$ can be expressed as

$$D[m, n] = \frac{J_0(2\pi f_d(m-n)T)}{(1+k)} + \frac{K(\cos(2\pi f_d(m-n)T \cos \theta_0))}{(1+k)} + \frac{jk(\sin(2\pi f_d(m-n)T \cos \theta_0))}{(1+k)} \dots (22)$$



2.7.1 Estimation of the Channel

In the channel estimation we need to regenerate the received signal in terms of time-domain markers. Here we assumed that, in the t_{th} iteration, the transmitted data symbol vector $X^{(t-1)}$, which is detected in the $(t-1)_{th}$ iteration, is available at the receiver.

$$R_q(k) = \sum_{p=1}^{M_T} \sum_{s=0}^{N-1} \sum_{l=0}^{L-1} \sum_{i=1}^M b_{m(i),p,q}^{k,s}(l) h_{p,q}(l, m(i)) X_p^{(t-1)}(s) + e_q(k) \dots (23)$$

Where $e_q(k)$ denotes the summation of the estimation error at subcarrier k and AWGN at the q_{th} receive antenna, and

$$b_{m(i),p,q}^l = \frac{1}{N} w_{s,l} \sum_{r=0}^{N-1} [A_{m(i)}^{p,q}]_{r,r} e^{j \frac{2\pi r(s-m)}{N}} \dots (24)$$

2.7.2 Interference cancellation

An iterative interference cancellation scheme, where in each and every iteration of the channel estimation, the ICI caused by the Doppler spread is suppressed by a PIC-DSC module [4]. Unlike [4], in our proposed method, the iterative channel estimation and PIC-DSC processes are combined into one iterative process. Here, instead of performing PIC-DSC and data detection for a number of times for every iteration of the channel estimation, as in [4], the PIC-DSC and data detection are performed once, and then, the detected data symbols are sent back to the channel estimator. This results in a lower computational complexity, compared to the technique in [4]. Furthermore, the proposed iterative channel estimation with the PIC-DSC interference cancellation scheme results in better symbol error rate (SER) performance, compared with [4]. In the proposed PIC DSC technique, the decision statistics in the t_{th} iteration for symbols transmitted from the p_{th} antenna are given as

$$Y_p^{(t)} = (H_{diag}^{(t)})_p (R - H_{ndiag}^{(t)} X^{(t-1)} - H_{diag}^{(t)} X_{(zero,p)}^{(t-1)}) \dots (25)$$

In a high-interference scenario, the detector output becomes unreliable. Under these conditions, Marinkovic *et al.* proposed to use a combining method called DSC, which gives an improved SINR. The decision statistics are generated by the DSC module as a weighted sum of the current PIC output $Y_p^{(t)}$ and the DSC output of the previous iteration $Y_{DSC,p}^{(t-1)}$. Therefore, the output of the DSC can be given by

$$Y_{DSC,p}^{(t)} = \frac{(\sigma_{DSC,p}^t)^2}{2} Y_p^{(t)} + \frac{(\sigma_p^t)^2}{z} Y_{DSC,p}^{(t-1)} \dots (26)$$

2.8 EXPERIMENTAL RESULTS AND ANALYSIS

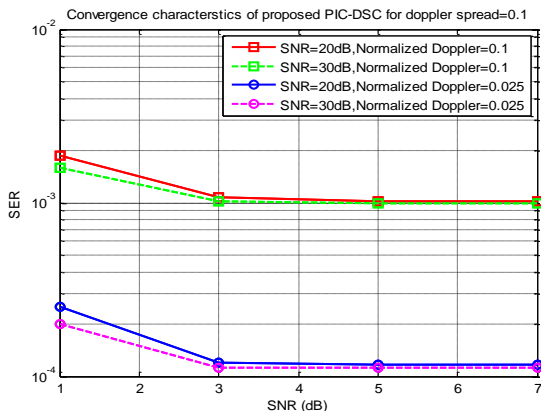

Fig: 3 Convergence characteristics of the proposed iterative channel estimation with the PIC-DSC interference cancellation scheme under various normalized Doppler spread.

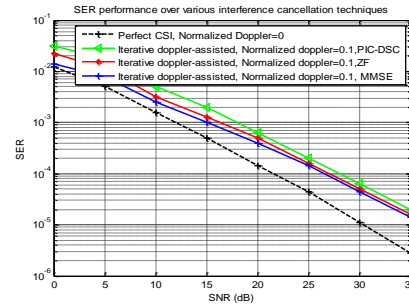

Fig: 4 Convergence characteristics of the proposed iterative channel estimation with the PIC-DSC interference cancellation scheme under various normalized Doppler spread

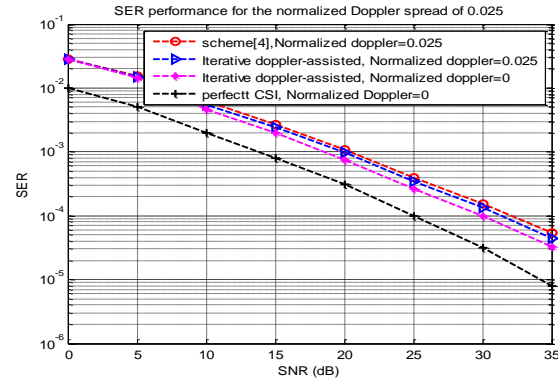

Fig:5 SER performances for the normalized Doppler spread of 0.025

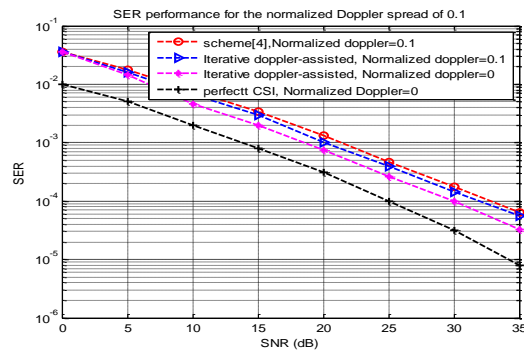

Fig: 6 SER performances for the normalized Doppler spread of 0.1

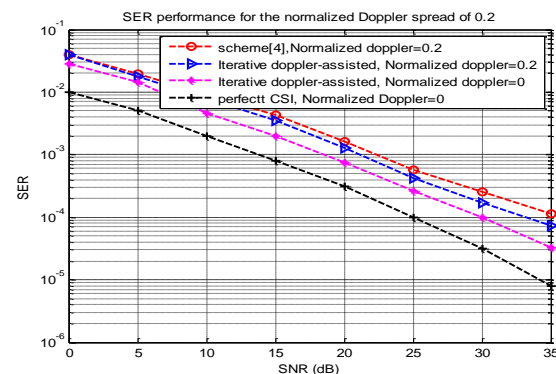

Fig: 7 SER performances for the normalized Doppler spread of 0.2

Table 1 - Comparison of SNR and SER for different techniques

SNR(Signal to Noise Ratio)	SER(Symbol Error Rate)		
	PIC-DSC	ZF	MMSE
0dB	0.03	0.021	0.015
20dB	0.0006	0.0005	0.0004
35dB	0.00002	0.000014	0.000013

Table 2 - Comparison of SNR and SER for different techniques

SNR(Signal to Noise Ratio)	SER (Symbol Error Rate)		
	Doppler spread (0)	Doppler spread (0.025) present	Previous technique (0.025)
0dB	0.03	0.03	0.03
20dB	0.0007	0.001	0.0012
35dB	3×10^{-4}	4×10^{-4}	5×10^{-4}

Table 3- Comparison of SNR and SER for different techniques

SNR(Signal to Noise Ratio)	SER (Symbol Error Rate)		
	Doppler spread (0)	Doppler spread (0.1) present	Previous technique (0.1)
0dB	0.03	0.03	0.03
20dB	0.0007	0.001	0.0013
35dB	3×10^{-4}	5×10^{-4}	5.5×10^{-4}

Table 4- Comparison of SNR and SER for different techniques

SNR(Signal to Noise Ratio)	SER (Symbol Error Rate)		
	Doppler spread (0)	Doppler spread (0.2) present	Previous technique (0.2)
0dB	0.03	0.03	0.03
20dB	0.0007	0.001	0.0013
35dB	3×10^{-4}	7×10^{-4}	1.1×10^{-4}

2.9 CONCLUSIONS

In this paper basic concept of OFDM and MIMO systems is discussed. The various channel and ICI cancellation techniques and their performance also discussed. Compared to the all technique the iterative channel estimation and ICI cancellation technique is best with high signal to noise ratio 30db and less symbol error rate 10^{-4} with the Doppler spread 0.2.

REFERENCES

1. Al-Naffouri T Y, Islam K M Z , Al-Dhahir N, and Lu S, “A model reduction approach for OFDM channel estimation under high mobility conditions,” IEEE Trans. Signal Process, vol. 58, no. 4, Apr. 2010, pp.2181–2193.
2. Aboutorb Neda “A New Iterative Doppler Assisted Channel Estimation Joint with Parallel ICI Cancellation For High Mobility MIMO-OFDM System” IEEE Trans. Commun., vol. 61 ,no 4 May 2012,pp.1577-1589.
3. Chang, R., “Synthesis of band limited Orthogonal Signals for multichannel data transmission.” Bell System Technical Journal. vol. 46, (December 1996): pp. 1775- 1796.
4. Hardjawana W, Li R, Vucetic B, and Li Y, “A new iterative channel estimation for high mobility MIMO-OFDM systems,” in Proc. VTC, May 2010, pp. 1–5.

5. Hua. J, Meng .L, Xu . X, Wang .D, and You .X, “Novel scheme for joint estimation of SNR, Doppler, and carrier frequency offset in double selective wireless channels,” IEEE Trans. Veh. Technol., vol. 58, no. 3, Mar. 2009, pp. 1204–1217.
6. Hua J, Xu Z, Meng J. Li, L., and You X, “Doppler shift estimator with MMSE parameter optimization for very low SNR environment in wireless communications,” IEEE Trans. Aerosp. Electron. Syst., vol. 44, no. 3, Jul. 2008, pp. 1228–1233.
7. Li Y G, “Pilot-symbol-aided channel estimation for OFDM in wireless systems,” IEEE Trans. Veh. Technol., vol. 49, no. 4, Jul. 2000, pp. 1207–1215.