

Energy Efficiency in Data Centers: How to Reduce Power Consumption in Data Centers by Optimum UPS Loading

N.P. Zinjad, S. S. More

Abstract— Computation and data center has a huge value to modern enterprise. This has resulted in the installation of millions of data centers in business around the globe. Historically, the cost to power and cool these facilities was small relative to the investment in servers, storage units and other equipments. Today, however, the annual power and cooling costs of typical data centers are almost equal to the cost of hardware. In the past decade, India has witnessed an exponential increase in the demand for digital storage, from 1 petabyte in 2001 to more than 34 petabytes by 2007. They also continue to grow at a compounded rate of 25-30%. Datacenter growth is basically driven by increasing requirements from the sectors such as financial institutions, telecom operators, manufacturing and services. While large financial institutions and telecom companies are likely to build captive Datacenters for hosting their growing data storage needs. Datacenter service providers are expected to invest significantly to multiply their capacities, so as to fulfill the demand arising from small and midsize users. Datacenter is highly energy intensive. With the increasing energy cost, the increase in operational cost is inevitable. Therefore it becomes necessary to reduce the energy consumption to offset the increasing operational cost and to maintain competitiveness. Existing Datacenters need to adopt the best practices in design, operation and maintenance to achieve operational excellence. The increasing IT business process outsource from foreign countries has resulted in phenomenal growth of Datacenters in India. The total datacenter capacity in India is growing at a rapid pace and is expected to exceed 5.1 million square feet by 2012. The primary scope of this paper is to provide a framework in which data centers, large and small, could analyze and reduce their power consumption. This paper provides a quantitative approach to understanding energy efficiency within a server and within a data center. A panorama for power minimization and energy efficiency beginning with the basics of dual in line memory modules (DIMM) selection, configuring processors with reduced power states, options for constantly spinning disks, power management features in operating systems and other internal equipments.

Index Terms— Loading optimization, Harmonics, Flywheel plus converter, Loading, Efficiency, Five “nines”, MTTF, MTBR, MTBF.

I. INTRODUCTION

As the trend shifts from paper-based to digital information management, Datacenters have become common and essential to the functioning of business systems. A Datacenter is a facility that has concentrated depository of various equipment such as servers, data storage devices,

network devices etc. Collectively, this equipment processes, stores, and transmits digital information and is known as

Information Technology (IT) equipment. Fundamentally, the Datacenter is a physical place that houses a computer network's most critical systems, including backup power supplies, air conditioning, and security applications. The Datacenter industry is in the midst of a major growth. The increasing reliance on digital data is driving a rapid increase in the number and size of Datacenters. This growth is the result of several factors, including growth in the use of internet media and communications and growth in the need for storage of enormous digital data. For example, Internet usage is increasing at approximately 10percent per year worldwide and has directly fuelled the growth of data centers. Power usage distribution in a typical Datacenter is shown in figure 1. From the figure 1, we understand that the IT equipment and its cooling system consume a major chunk of power in a Datacenter. Also, the cooling requirement in a Datacenter is based on the energy intensity of IT load in the Datacenter. Therefore, energy savings in IT load would have a direct impact on the loading of most of the support systems such as, cooling system, UPS system, power distribution units and thereby has effect on overall energy performance of the Datacenter. Typically the cooling system consumes 35 – 40 % of the total Datacenter electricity use. Demands on cooling systems have increased substantially with the introduction of high density servers. As a result, the cooling system represents the second highest energy consumer next to IT load.

II. UNINTERRUPTED POWER SUPPLY (UPS) SYSTEM

The Uninterruptible Power Supply is the heart of any critical power infrastructure. The UPS provides the primary protection from harmful power disturbances as well as gives a linkage to stored energy source or alternative power sources during times of outage.

Manuscript Received June 11, 2011.

N.P. Zinjad, Research Scholar, Department of Electrical Engineering, BVDU COE, Pune, India

Mrs. S. S. More, Professor & Head Department of Electrical Engineering, BVDU COE, Pune, India.

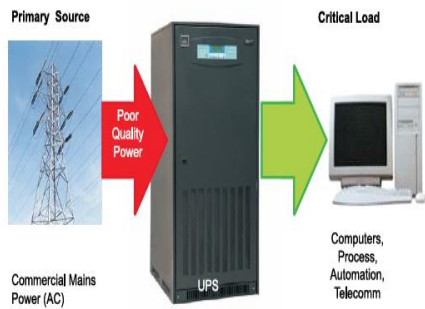

The UPS, acting as both a load and a source, transforms this poor quality power to high-quality power, which can then be safely applied to critical loads. Commercial Power containing spikes, sags, and outages would cause data loss and several damage to IT infrastructure in a Datacenter. An Uninterruptible Power Supply (UPS) is used to protect Datacenters from an unexpected power disruption which would cause data loss resulting in disastrous consequences for the company.

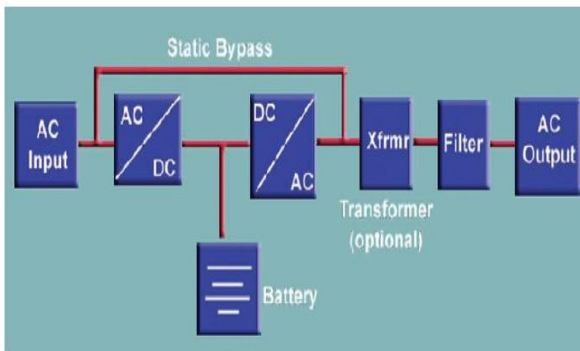

Fig 1: UPS system

The UPS is one of the most critical pieces of equipment in a Datacenter. Typically, online UPS systems are used in Datacenters. These systems are ideal for environments where electrical solution is necessary or the equipment in use is highly sensitive to power fluctuations. Traditionally, the selection of UPS systems has focused on system reliability without giving much thought to the system efficiency. However, with the increase in energy costs and as a consequence of the energy shortage situation, the efficiency of the UPS system has now become a major consideration, while reliability still remains as the topmost criteria. In order to have redundancy level in a Datacenter, the number of UPS systems is increased. This eventually leads to decrease in the loading of UPS systems. The Loading vs. Efficiency curve is shown in the Figure.

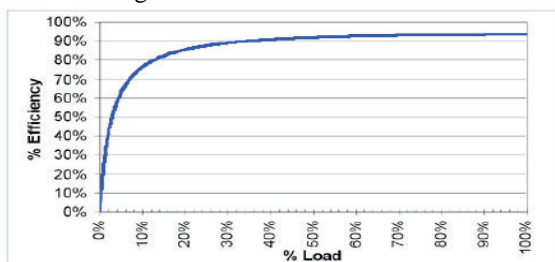
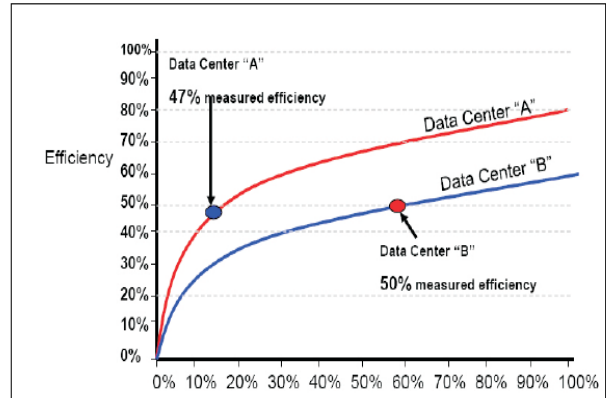

Fig 2: Loading v/s Efficiency graph

The curve shows that, in most cases, the operating efficiency of the UPS system reduces due to lower load on the UPS. The change in efficiency with varying load has another important effect on the interpretation of operating efficiency. Consider the case of the two Datacenters being compared in Figure.



Datacenter A appears to have the better design efficiency and it may seem reasonable to assume that it is a “Greener” Datacenter of fundamentally superior design. However, consider the detailed view of these two Datacenters as shown in figure, the design efficiency of Datacenter A is higher than that of Datacenter B. Nevertheless, the operating efficiency of Datacenter A is lower than that of Datacenter B if Datacenter A faces only 14% loading and Datacenter B faces 58% loading. The Low operating efficiency is due to a low percentage load on the IT equipment and therefore on the overall infrastructure. Low operating efficiency is due to the following reasons:

1. Varying load requirements with respect to time
2. Over-sizing of equipment by design
3. Installation of multiple equipment to facilitate higher redundancy level

Various techniques are available to optimize the loading of the UPS system and to optimally share the load on all the UPS systems. Modularity is one such method to improve the efficiency of the UPS system. Modularity allows users to size the UPS system as closely with the load as practical (in other words, it allows the UPS to operate as far right on the curve as possible). UPS technologies continue to evolve towards greater electrical efficiency and the newer technologies available will yield greater benefits.

III. CASE STUDY

This is the case study done on the leading IT Company of India. The readings in form of case study were done at 1130 hours IST and 1400 hours IST. The company basically has two blocks which have 3 sets of 200kVA UPS and two sets of 60 kVA UPS each. This case study was done from 1st January 2012 to 7th January 2012. The details of two days are tabulated here.

DAY 1:

Date	Time	UPS	Loading	Efficiency
1/1/2012	11:00	200kVA "A"	70%	90
		200kVA "B"	18%	85
		200kVA "C"	19%	80
		60kVA "A"	2%	20
		60kVA "B"	1%	15

The graph for the relation between Loading and Efficiency is as follows:

Graph set: 1/1/2012 at 1100 hours

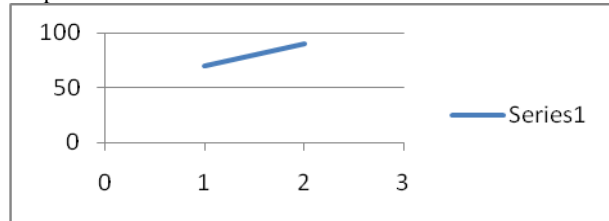

200kVA "A"

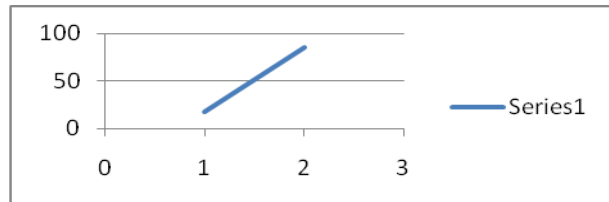

200 kVA "B"

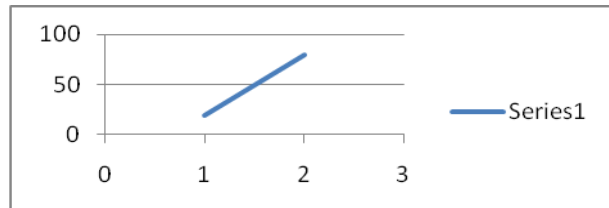

200 kVA "C"

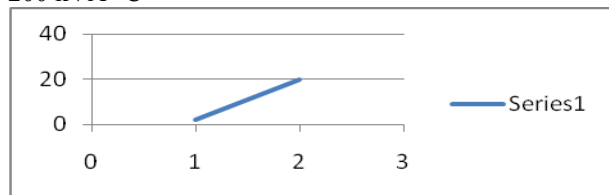

60 kVA "A"

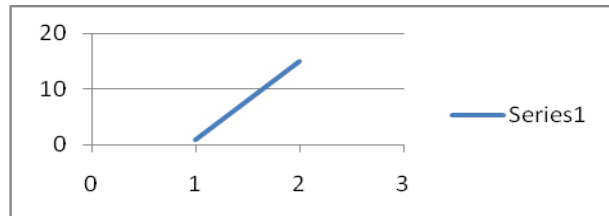

60 kVA "B"

DAY 2:

Date	Time	UPS	Loading	Efficiency
2/1/2012	11:00	200kVA "A"	71%	90
		200kVA "B"	32%	85
		200kVA "C"	35%	80
		60kVA "A"	2%	20

		60kVA "B"	1%	15

Graph set: 2/1/2012 at 1100 hours

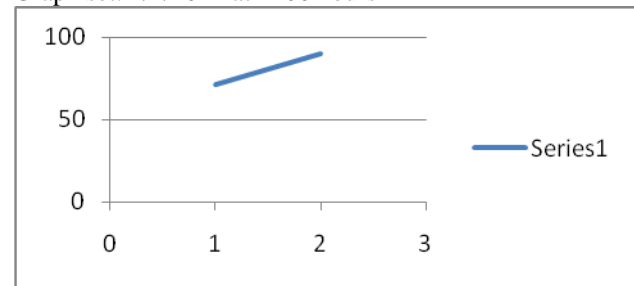

200kVA "A"

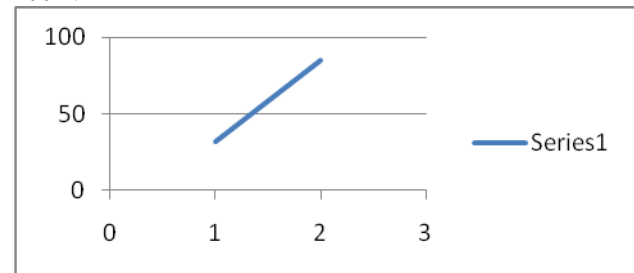

200kVA "B"

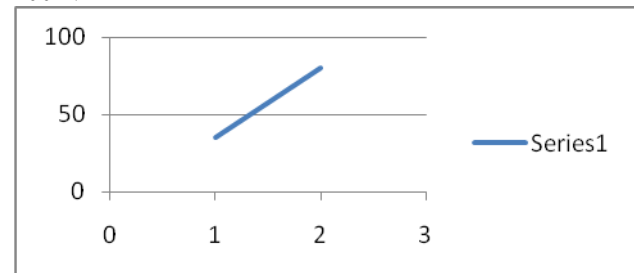

200kVA "C"

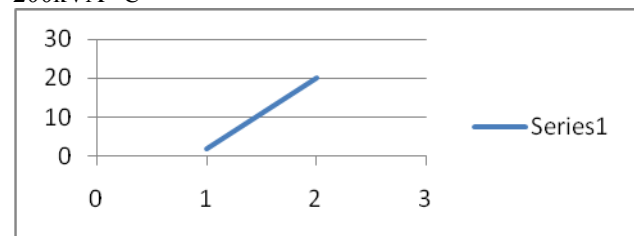

60kVA "A"

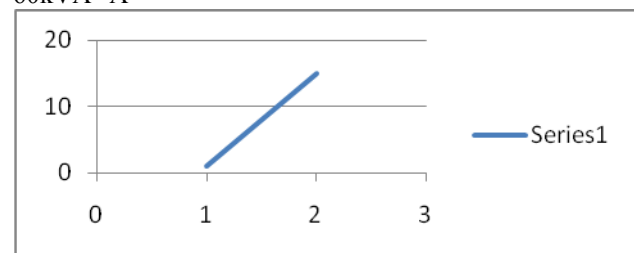

60kVA "B"

If we compare to the graph of figure 2, one can see that as far as the loading is limited between 80 – 95%, efficiency ranges in between 90 – 95%. But as the loading decreases, efficiency decreases drastically. The graph should float in the region of 80 – 90 percent efficiency; more like 200kVA "A" which is nearly optimum loaded 72%.

The magnitude in which the graph comes to the X – axis the systems shows that the UPS is not loaded optimum and there is every scope of making that system energy efficient.

IV. NEWER TECHNOLOGIES

There are two distinct variants of Battery-Less UPS. One which uses a Static UPS combined with Flywheel plus Flywheel converter as shown in Figure 3 below. Flywheel plus Converter acts as alternative to the Batteries. In this case, during Utility Power supply outage the Kinetic energy of Flywheel-rotation gives the backup / ride-through to the Inverter for a few seconds till the Generator is energized and connected to the Rectifier. The second one as shown in Figure uses a Rotary Motor-Generator Set-up coupled with a Diesel / Natural Gas Engine through a Clutch arrangement and a Flywheel plus AC-DC-AC Converter (which is a Static Element). This is, therefore, also known as a Hybrid UPS since it actually uses a combination of Rotary and Static Elements. Both the above variants leave option for connection of Batteries also. While the Flywheel provides a ride-through of a few seconds upon Utility failure, the Engine starts and connects through the Clutch meanwhile, maintaining the rotational energy to the generator which in turn maintains the Power Supply to the Loads.

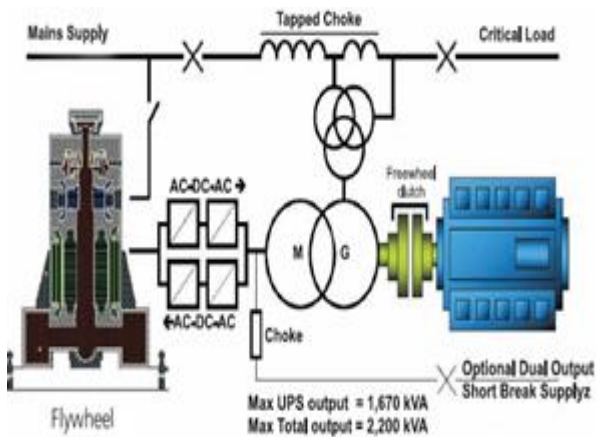

[Fig.-3: Schematic of Rotary UPS System]

A. High Availability Power System

The computing industry talks of availability in terms of “Nines”. This refers to the percentage of time in a year that their system is available, on-line, and capable of doing productive work. A system with four “Nines” is 99.99% available, meaning that downtime is less than 53 minutes per year. Five “Nines” (99.999% available) equates to less than 5.3 minutes of downtime per year. Six “Nines” (99.9999% available) equates to just 32 seconds of downtimes per year.

Improving Availability means improving MTBF and/or reducing MTTR. This will not yield the significant improvement truly critical operations need to go beyond 99.999%.

B. Determination of Availability

$$Availability = \frac{MTBF}{(MTBF + MTTR)}$$

MTBF (Mean time before failure) =increased Reliability

MTTR (Mean Time between Repair) = Fast Recovery

MTBF (Mean Time between Failures)

The reliability of the Datacenter is inversely proportional to the time taken between failures.

For Paralleled Systems:

$$MTBF = MTBF_1 + MTBF_2 + \frac{(MTBF_1 \times MTBF_2)}{MTTR}$$

V. CONCLUSION

The Data centers are not fully operated at maximum possible loading. Data centers operators or owners should operate the UPS at maximum possible loading which reduces the extent of power consumption to a great extent.

REFERENCES

1. Datacenter book; Publisher: BEE India
2. Energy Efficiency in Data Centers; Publisher: Intel
3. www.leonardo energy.com
4. APC journals
5. www.schneider electricals.com
6. www.cockvalley.com
7. Configuring your UPS; Publisher: EAMS