

# A Novel Approach on Harmonic Elimination in Single Phase Systems by Means of a Hybrid Series Active Filter (HSAF)

I. V. Koteswara Rao, K. Sujesh, S. Radha Krishna Reddy, Y. Naresh Kumar, CH. Kamal

**ABSTRACT-** *In this paper, a fully-digital-controlled Hybrid Series Active Filter (HSAF) for harmonic elimination and reactive power compensation in single phase systems is presented. The HSAF is composed of two single tuned LC filters and a small-rated active filter. Discrete Fourier transformation is used as the control method. Simulation results using MATLAB program shows the effectiveness of the control method. A hybrid series active filter is implemented verifying the accuracy of the control method.*

**Keywords:** – *Hybrid series active filter, single phase active filter, harmonic elimination, reactive power compensation, detection methods, power quality.*

## I. INTRODUCTION

With the developments of power electronic equipments and nonlinear loads, the power quality has been deteriorating in distribution system. Current harmonics can cause serious harmonic problems in distribution feeders for sensitive consumers. Some technology options have been reported in order to solve power quality issues. Initially, lossless passive filters have been used to mitigate harmonics and compensate reactive power in nonlinear loads. However, passive filters have the demerits of fixed compensation, large size and resonance with the supply system. Active filters have been explored in shunt and series configurations to compensate different types of nonlinear loads; nevertheless, they have some drawbacks. As a case in point, their rating is sometimes very close to load, and thus it becomes a costly option for power quality improvement. Many researchers have classified different types of nonlinear loads and have suggested various filter options for their compensation. In response to these factors, a series of hybrid filters has been evolved and extensively used in practice as a cost effective solution for the compensation of nonlinear loads.

**Manuscript received March 17, 2012**

**I. V. Koteswara Rao**, Pursuing M. Tech. Degree Electrical Power Systems from Holy Mary Institute of Tech & Science (coe), Bogaram, Rangareddy (dist), Hyd. J.N.T.U. Hyderabad (Email: vkoteswar.indla@gmail.com).

**K. Sujesh**, Assistant Professor in Holy Mary Institute of Technology & Science, Bogaram, R.R. Dist, Hyderabad, Andhra Pradesh, India (Email: k\_sujesh@ymail.com).

**S. Radha Krishna Reddy**, Associate Professor in Holy Mary Institute of Technology & Science, Bogaram, R.R. Dist, Hyderabad, Andhra Pradesh, India (Email: krissingapore2006@gmail.com).

**Y. Naresh Kumar**, "Assistant Professor" in Holy Mary Institute of Technology & Science (HITS) in the Dept. of Electrical & Electronics Engineering (EEE), Bogaram (V), R.R. Dist, Hyderabad, Andhra Pradesh, India (Email: naresh.eee2006@gmail.com).

**CH. Kamal**, Assistant Professor in Holy Mary Institute of Technology & Science, Bogaram, R.R. Dist, Hyderabad, Andhra Pradesh, India (Email: kamal4u.eee@gmail.com).

State-of-the-art power electronic technology has enabled engineers to put active filters into practical use. Many shunt active filters consisting of voltage-fed pulse width modulated (PWM) inverters using IGBT or GTO thyristors are operating successfully in all over the world. These filters have provided the required harmonic filtering, reactive power compensation, and etc [1-2]. An important technology on active filters is the detecting method of harmonics to reduce the capacity of the energy storage components. Various control strategies have been proposed in recent publications for this type of active filters [3-16]. The control strategy presented in [3] is based on the calculation of the real part of the fundamental load current while this is useful in some configurations such as hybrid series active filter, since it cannot compensate reactive power completely and needs many complicate calculations. The active power filter proposed in [4]–[5] uses a dc capacitor voltage

Closed loop control; in [6] the author uses an adaptive method with Kalman filter to predict reference current; in [7] and [8] the authors use a modified phase-locked loop for extraction of the reference current. In the cited references, the computation involves various control parameters or needs complex calculations. Also, the dynamic performance of the compensator is not desire in the case of fast-changing loads.

The least compensation current control method presented in [9] is based on detection of the harmonics and reactive current of the active power filter. In [10], genetic algorithm and extended analysis optimization techniques were applied for switched capacitor active filters. A combined genetic algorithm conventional analysis control technique [11] has been considered as a recent control approach. These control strategies have a common drawback concerning the global stability of the closed-loop system. In [12], the control method is based on the calculation of average power; this needs to know some information about system and requires intense calculation. The sliding-mode control method proposed in [13] solves the stability problem; however, the calculation technique for compensation of current reference is complicated and switching frequency is variable. In [14], a digital repetitive control approach is presented to obtain high gain for the current loop; nevertheless, the control strategy in this approach is based on a linearized model of the active filter and does not lead to global stability.

## A Novel Approach on Harmonic Elimination in Single Phase Systems by Means of a Hybrid Series Active Filter (HSAF)

A deadbeat control strategy is introduced in [15] for the current loop of single-phase active filters. Although this method has a fast current control due to the deadbeat nature, its dependency on parameters is a basic disadvantage. Furthermore, the need for prediction of the current reference requires adaptive signal processing techniques, complicating the implementation of this technique. Passivity based controllers [16] based on phasor models of system dynamics have also been proposed in an attempt to improve the stability properties of active filters.

This paper uses a Discrete Fourier transform for single phase active power filters (APF) that is organized as follows: section II shows the hybrid series active filter (HSAF) configuration for harmonic elimination and reactive power compensation; section III presents the control method; section IV shows stability analysis of the proposed configuration; section V shows frequency response of the proposed configuration; section VI presents the simulation results of this method for a hybrid series active filter, and section VII presents the experimental results of this method for a HSAF.

**TABLE I. System parameters used in simulations**

Parameter	Values
Power source voltage : Vs(V)	220
System equivalent inductance: Ls(mH)	.48
Load input inductor: LAC(mH)	3
Filter capacitor of 3rd: C3f(μf)	25
Filter inductance of 3rd: L3f(mH)	45
Filter capacitor of 5rd: C5f(μf)	25
Filter inductance of 5rd: L5f(mH)	16
dc capacitor: Cdc(μf)	1500
Load capacitor: CL(μf)	2100
Load resistance: RL(Ω)	40
Power system fundamental frequency : (Hz)	50

### II. HARMONIC ELIMINATION USING A HYBRID SERIES ACTIVE FILTER (HSAF)

The active filters can be classified into pure active filters and hybrid active filters in terms of their circuit configuration. Most pure active filters as their power circuit can use either a voltage-source pulse width-modulated (PWM) converter equipped with a dc capacitor or a current-source PWM converter equipped with a dc inductor. At present, the voltage source converter is more favourable than the current-source one in terms of cost, physical size, and efficiency. Hybrid active filters consist of single or multiple voltage-source PWM converters and passive components such as capacitors, inductors, and/or resistors. The hybrid filters are more attractive in harmonic filtering than the pure filters from both viability and economical points of view, particularly for high-power applications. However, single-phase active filters would attract much less attention than

three-phase active filters because single phase versions are limited to low-power applications except for electric traction or rolling stock [17].

Fig. 1 shows the configuration of the HSAF and nonlinear load proposed in this paper and, its parameters are given in table I. The HSAF consists of a series active filter and two parallel single tuned passive filters in series with the active filter. Two passive filters are tuned in dominant harmonic frequencies of 3<sup>rd</sup> and 5<sup>th</sup>. The effectiveness of the proposed method in harmonic elimination and reactive power compensation is shown using HSAF for a nonlinear load. In the following sections, the control method, the design process and simulation results are given.

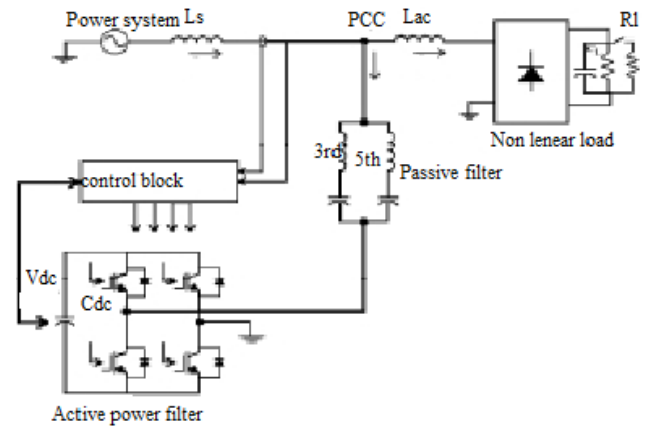

**Fig. 1. System configuration**

### III. COMPENSATION STRATEGY

One of the key points for proper implementation of an APF is to use a reliable method for current/voltage reference generation. Currently, there is a large variety of practical implementation supported by different theories (either in time or frequency domain). The control method should extract the harmonic components with minimum phase shift and attenuate the fundamental component. In this paper discrete Fourier transformation (DFT) is used to extract the source current harmonics with assuming  $N$  samples in a cycle, as:

$$X_1 = \sum_{k=0}^{N-1} x_k e^{j2\pi k/n} \quad (1)$$

$$x_{k1} = \frac{1}{N} X_1 e^{-j2\pi k/n} \quad (2)$$

where (1) is DFT and (2) is inverse DFT. After extracting the fundamental component, it is subtracted from source current to extract harmonic components as:

$$i_{sh} = i_s - i_{s1} \quad (3)$$

Fig. 2 shows the control circuit. A method was proposed by Akagi [17] to control the dc voltage capacitor. Based on this method, if active filter is along the passive filter, an extra voltage reference should be added to q component. As seen in this figure, a component with 90 degree lead the load terminal voltage is added to reference voltage in order to control the dc link voltage capacitor.

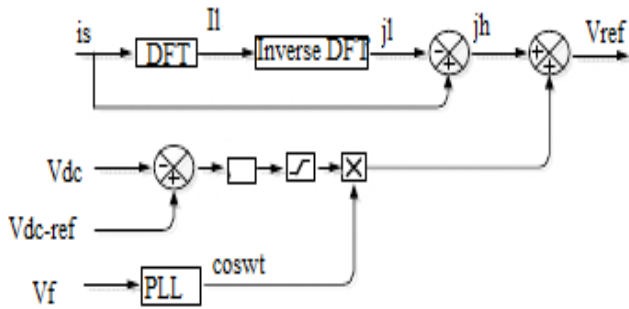

Fig. 2. Control circuit of hybrid series active filter.

IV. SYSTEM STABILITY ANALYSIS

Fig. 3 shows whole system block diagram. Active filter shows zero impedance against fundamental component of the source current while it shows high impedance against harmonics. In Fig. 3, analog to digital converters in control circuit give rise to some delays in system. Also, it takes some time to extract harmonic components by the microcontroller. Assuming all the delays in the system as  $\tau$ , Fig. 4 shows the system control diagram. So, the open-loop transfer function will be as:

$$G(s) = \frac{K}{sL + Z_F} e^{-s\tau} \quad (4)$$

Eqs. (4) represents that if  $\tau$  is zero, the system will always be stable. However, the existence of noise is unavoidable. Fig. 5

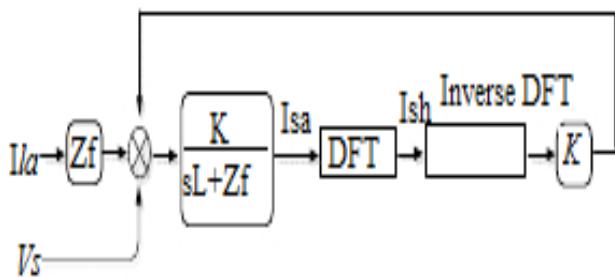

Fig. 3. Block diagram of the whole system.

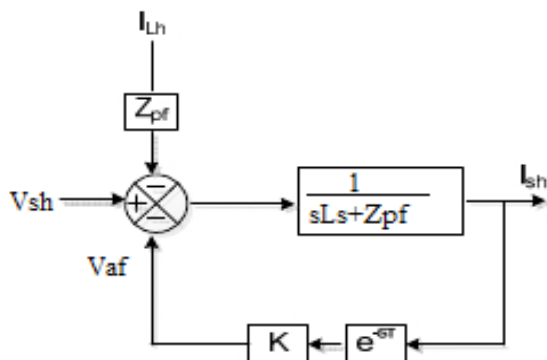

Fig. 4. Control diagram of the system with constant delay

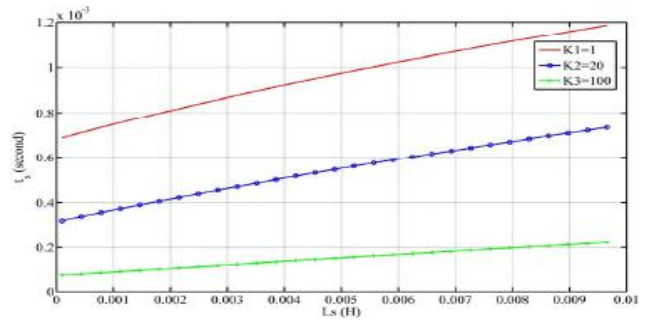

Fig. 5. Relationship between system critical time and system impedance.

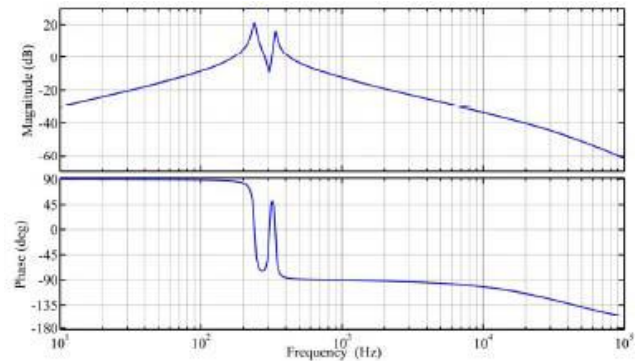

Fig. 6. System frequency response.

shows the relationship between system critical time ( $\tau$ ) and system impedance in different values of  $K$ . As seen in this figure, as  $K$  increases, the system critical time decreases to avoid instability; however, the source current THD decreases. Fig. 6 shows the system frequency response. As this figure shows, the system is stable and its phase margin is about 90 degree.

V. FREQUENCY CHARACTERISTIC OF THE SYSTEM

Single phase harmonic equivalent circuit of the power system, shown in Fig. 1, is demonstrated in Fig. 7. In this figure, the voltage source harmonics are modelled by  $V_{sh}$ , and it's in series with the Thevenin impedance ( $Z_s$ ) of the power system. Also, nonlinear load is a diode rectifier by a resistive capacitive load on its output. This load has usually a voltage source characteristic because an inductor is on rectifier input, and this makes it as a current source type load characteristic. The load is modelled by harmonic voltage  $V_{Lhv}$  in series with inductor  $LAC$ . The series active filter behaves as a damping resistor which can eliminate resonance between the parallel passive filter and the source impedance. It also prevents flowing of harmonic currents to the power source by presenting zero impedance at the fundamental frequency and a high resistance  $K$  at the power source or load harmonics. So, the series active filter can be modelled by a resistor,  $K$ , and its output reference voltage as:

## A Novel Approach on Harmonic Elimination in Single Phase Systems by Means of a Hybrid Series Active Filter (HSAF)

$$V_{af} = Ki_{sh} \quad (5)$$

where  $I_{sh}$  is the harmonic current flowing from the power source produced by both the load harmonic current ( $I_{Lh}$ ) and the power source harmonic voltage ( $V_{sh}$ ). Consequently, from the model shown in Fig. 7, the harmonic current of the power source is calculated as:

$$I_{sh} = \frac{Z_{pf}}{Z_s + Z_{pf} + K} I_{Lh} + \frac{V_{sh}}{Z_s + Z_{pf} + K} \quad (6)$$

where  $Z_s$  and  $Z_{pf}$  are power source and passive filter equivalent impedance, respectively.

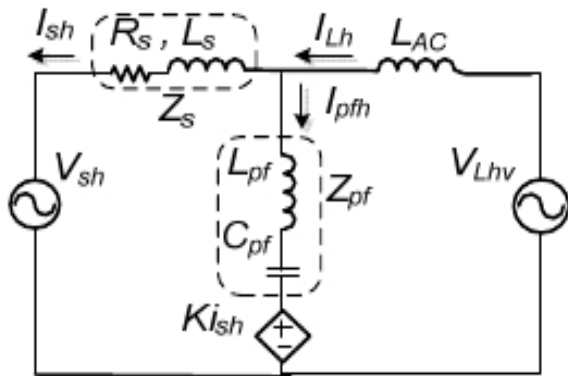

**Fig. 7. Harmonic equivalent circuit of single phase system.**

Based on (6), when  $K$  is large enough greater than  $Z_s$  and  $Z_{pf}$ , the power source harmonic currents will be equal to zero ( $I_{sh}=0$ ). In fact, in this case the source impedance ( $Z_s$ ) has no impact on the parallel passive filter characteristic, and the power source current harmonics will completely be eliminated. If the power source voltage harmonics ( $V_{sh}$ ) is not considered, the load current will be divided between the passive filter and the power source; in this case, the ratio between the power source harmonic current and the load harmonic current is:

$$\frac{I_{sh}}{I_{Lh}} = \frac{Z_{pf}}{Z_s + Z_{pf} + K} \quad (7)$$

Fig. 8 shows the frequency response for different values of  $K$ . As seen in this figure, when the passive filter is used alone ( $K=0$ ), two resonances occur between the parallel passive filter and the power source impedance at about 130 Hz and 240 Hz. Also, when the series active filter is used along with the passive filter, since the series active filter behaves as a damping resistor, there is no resonance in the system.

### VI. SIMULATION RESULTS AND DISCUSSION

Harmonic elimination and reactive power compensation by HSAF is shown in this section through simulation. A HSAF with the process presented above is simulated in MATLAB. In this simulation two single tuned passive filters were used with the parameters given in Table I.

Fig. 9 shows the simulation results when the active filter is in off-line mode. The power source current THD ( $i_L$ ) without compensation is calculated about 70 %. Also, in passive filter compensation mode, the THD of the power source current

(is) decreases from 70% to about 41 %. Yet, this value has not been below the recommended value in standards such as IEEE 519-1992 [21] and IEC61000 [22]. To decrease the value of the THD, the active filter is employed with the dc capacitor voltage of 85 V. Fig. 10 shows the simulation results in this case. The THD of the power source current (is) decreases from 41% in off-line active filter mode to about 4.9 % in on-line active filter mode.

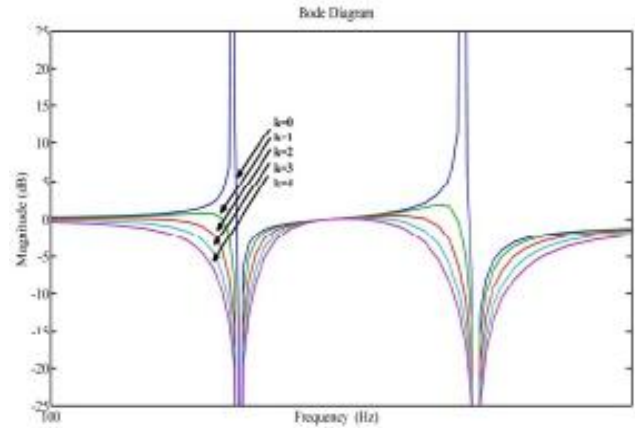

**Fig. 8. Frequency response of the hybrid series active filter for different values of  $K$ .**

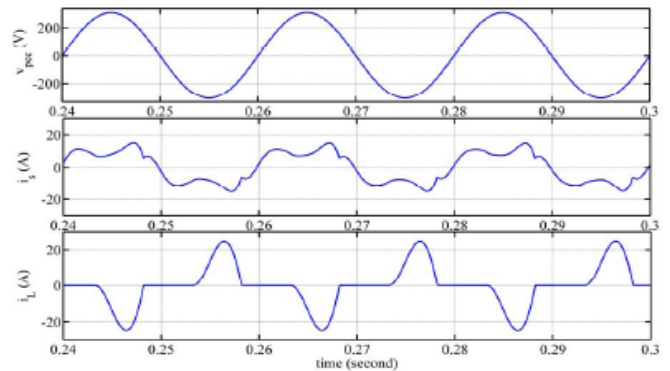

**Fig. 9. Simulated waveforms of compensated system with passive filter.**

### VII. EXPERIMENTAL RESULTS

#### A. System Configuration

A 220 V – 2.2 kW laboratory prototypes was implemented to verify the viability and accuracy of the proposed control method, shown in Fig. 11. Also, the parameters used in the manufactured system are given in Table II. It is noted that the passive filter utilized in this implementation is tuned to eliminate 3rd and 5th harmonics. The dc bus voltage is 65 V, and the IGBT switch is employed in the active filter. The proposed control method was implemented using a digital signal processor (TMS320F2812 DSP). First, the DSP calculates the reference voltage for the active filter; then, the calculated reference voltage is used to generate PWM gate signals for the IGBT switches while the modulation index is about 0.5.

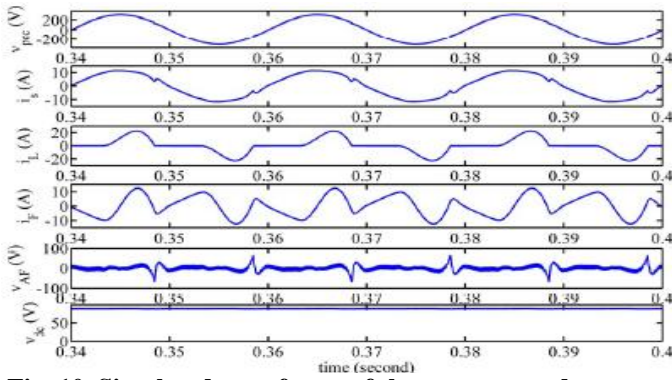

Fig. 10. Simulated waveforms of the compensated system with the hybrid series active filter.

**B. Experimental Results**

Fig. 12 shows the experimental waveform of the power source current without any compensation. In this case, the THD of the power source current is calculated about 78%. In Fig. 13 the same current with passive filter is demonstrated with the THD of about 21%. Fig. 14 shows the power source current with both the active and the passive filter. In this case, the THD reduces to about 6.3%.

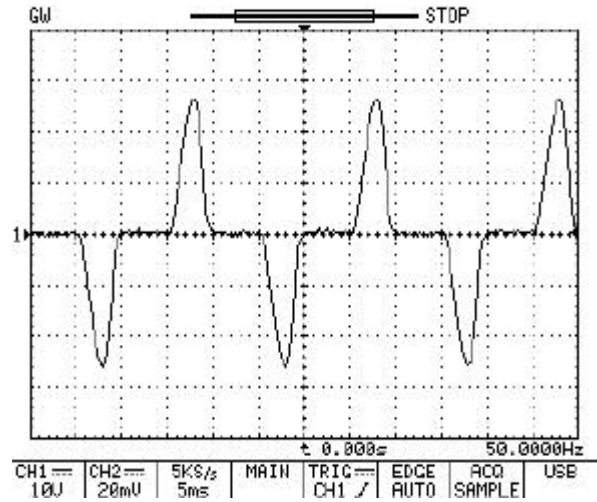

Fig. 12. Experimental waveform of nonlinear load current.

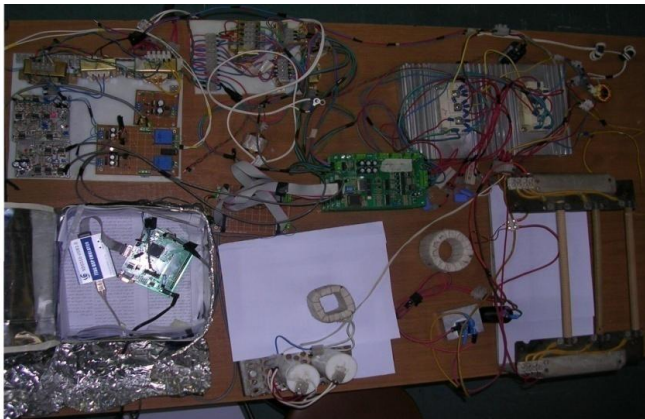

Fig. 11. Laboratory 220 V – 2.2 kW hybrid series active filter.

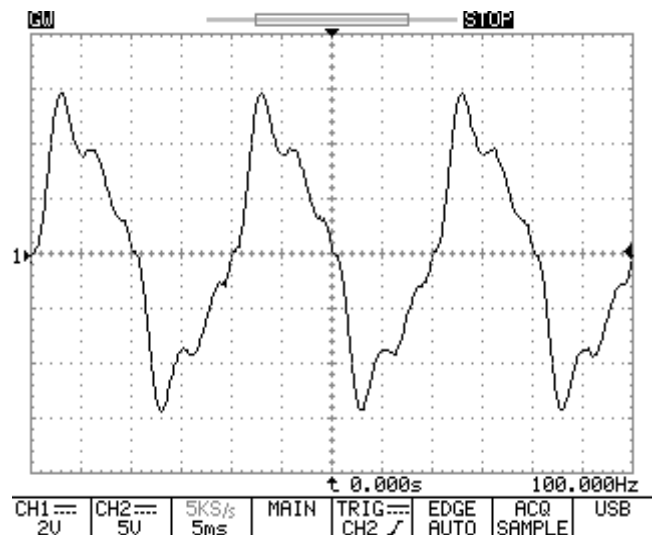

Fig. 13. Experimental waveform of the power source current with the passive filter only.

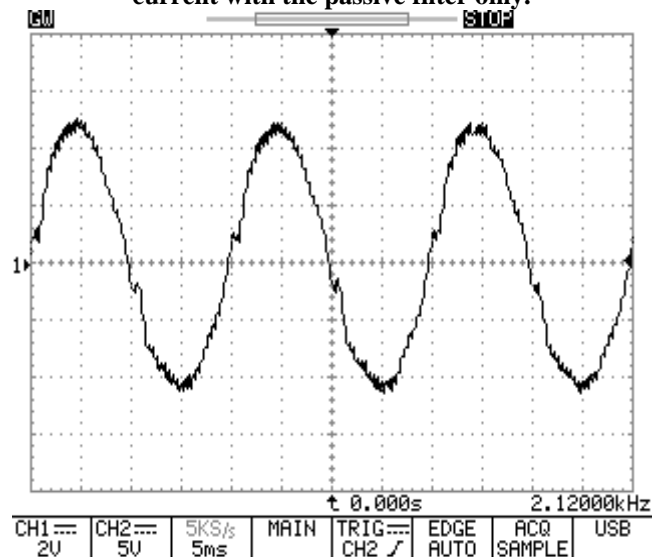

Fig. 14. Experimental waveform of the power source current with both the active and the passive filter.

**VIII. CONCLUSION**

This paper presents a fully digitally controlled HSAF for harmonic elimination and reactive power compensation in a single phase system with a control method for series active filter. This method is applicable in both single and three phase systems. The main advantage of the presented series active filter is that its filter's power rating is 10% of the load making it a cost-effective solution for high power applications. The performance of the proposed control method is simulated for a HSAF. The simulation results show the effectiveness of the presented method. Also, to investigate the effectiveness of this method reality, a laboratory prototype 220 V– 2.2 kW HSAF is implemented.

**REFERENCES**

1. B. Singh, A. Chandra and K. Alhaddad, "Hybrid Filters for Power Quality Improvement," IEE Proc. Gener. Transm. Distrib., vol. 152, pp. 365 - 378, no. 3, May 2005.
2. Fang Z. Peng, "harmonic sources and filtering approaches," IEEE Industry Applications Magazine, vol. 7, pp. 18 - 25, Jul. /Aug. 2001.
3. J. C. Wu and H. J. Jou, "Simplified control method for single-phase active power filter," Proc. Inst. Elect. Eng., vol. 143, pp. 219 - 224, no. 3, May 1996.
4. H. L. Jou, J. C. Wu, and H. Y. Chu, "New single-phase active power filter," Proc. Inst. Elect. Eng.—Electr. Power Appl., vol. 141, pp. 129–134, no. 3, May 1994.
5. C. Y. Hsu and H. Y. Wu, "A new single-phase active power filter with reduced energy-storage capacity," Proc. Inst. Elect. Eng. Electr. Power Appl., vol. 143, pp. 25–30, no. 1, Jan. 1996.
6. J. Barros, E. Perez, "An Adaptive Method for Determining the Reference Compensating Current in Single-Phase Shunt Active Power Filters," IEEE Trans. Power Del., vol. 18, pp. 1578 – 1580, no. 4, Oct. 2003.
7. M. Karimi-Ghartemani, H. Mokhtari, and M. R. Iravani, "A signal processing system for extraction of harmonics and reactive current of single phase systems," IEEE Trans. Power Del., vol. 19, pp. 979–986, no. 3, Jul. 2004.
8. M. K. Gharatemani and M. R. Iravani, "A nonlinear adaptive filter for online signal analysis in power system: application," IEEE Trans. Power Del., vol. 17, pp. 617–622, no. 2, Apr. 2002.
9. L. Zhou and Z. Li, "A novel active power filter based on the least compensation current control method," IEEE Trans. Power Elec., vol. 15, pp. 655–659, No. 4, Jul. 2000.
10. M. Welsh, P. Mehta, and M. K. Darwish, "Genetic algorithm and extended analysis optimization techniques for switched capacitor active filters - Comparative study," Proc. Inst. Elect. Eng.—Electr. Power Appl., vol. 147, pp. 21–26, no. 1, Jan. 2000.
11. M. El-Habrouk and M. K. Darwish, "A new control technique for active power filters using a combined genetic algorithm/conventional analysis," IEEE Trans. Ind. Elec., vol. 49, pp. 58–66, no. 1, Feb. 2002.
12. L. P. Kunjumammed, M. K. Mishra, "A Control Algorithm for Single Phase Active Power Filter under Non-Stiff Voltage Source," IEEE Trans. Power Elec., vol. 21, pp. 822 - 825 No. 3, May 2006.
13. D. A. Torrey and A. M. A. M. Al-Zamel, "Single-phase active power filters for multiple nonlinear loads," IEEE Trans. Power Elec., vol. 10, pp. 263–272, no. 3, May 1995.
14. R. C. Castello, R. Grino, and E. Fossas, "Odd-harmonic digital repetitive control of a single-phase current active filter," IEEE Trans. Power Elec., vol. 19, pp. 1060–1068, no. 4, Jul. 2004.
15. K. Nishida, M. Rukonuzzman, and M. Nakaoka, "Advanced current control implementation with robust deadbeat algorithm for shunt single phase voltage-source type active power filter," IEE Proc. Elect. Eng. Electr. Power Appl., vol. 151, pp. 283–288, no. 3, May. 2004.
16. A. M. Stankovic, G. Escobar, and P. Mattavelli, "Passivity-based controller for harmonic compensation in distribution lines with nonlinear loads," in Proc. IEEE Power Elec. Specialists Conf. (PESC), vol. 3, pp. 1143–1148, Jun. 2000,
17. H. Akagi, "Active Harmonic Filters," in Proc. IEEE, vol. 93, pp. 2128 – 214, no. 12, Dec. 2005.
18. S. Bhattacharya and D. M. Divan, "Synchronous frame based controller implementation for a hybrid series active filter system," Ind. App. Conf., Thirtieth IAS Annual Meeting, IAS '95., vol. 3, pp. 2531 - 2540, Oct. 1995.
19. Wu Longhui, Zhuo Fang, Wang Zhaoan, "Soft Phase Locked Loop for Active Power Filter Applied in Small Rating Stand-alone Power System," Power Elec. Specialists Conf. (PESC 2007). , pp. 2600 - 2606, Jun. 2007.
20. F. D. Freijedo, J. Doval-Gandoy, O. Lopez and J. Cabaleiro, "Robust Phase Locked Loops Optimized for DSP Implementation in Power Quality Applications," Ind. Elec. 34th Annual Conf. of IEEE (IECON 2008), pp. 3052-3057, Nov. 2008.
21. IEEE Std. 519-1992, "IEEE Recommended Practice and Requirements for Harmonic Control in Electric Power Systems," Published by IEEE, 1992.
22. Electromagnetic Compatibility (EMC)—Part 3-4 Limits—Limitation of Emission of Harmonic Current in Low-Voltage Power Supply Systems for Equipment With Rated Current Greater Than 16 A, IEC Std. 61000- 3-4-1998.

**AUTHORS PROFILE**



**I.V.KoteswaraRao** was born in Markapur, India, in 1987. He received the B.Tech. degree in Electrical & Electronics Engineering from Khader Memorial College of Engg & Tech, Devarakonda, J.N.T.U.Hyd in 2008. Presently he is pursuing the M.Tech.Degree Electrical Power Systems from Holy Mary Institute of Tech & Science(coe), Bogaram, Rangareddy (dist), Hyd.J.N.T.U. Hyderabad. He is interested in Power Systems, FACTS.



**K.Sujesh** received the B.Tech, degree in EEE from Netaji Institute of Engineering and Technology, Tooprapet, Nalgonda(Dt), Andhra Pradesh, India, from JNTU University and M.E. in Power systems & Power Electronics(PS&PE) from Chaitanya Bharathi Institute of Technology, Gandipet, Hyderabad from Osmania University in the year 2010. I have teaching experience of nearly 01 year & Currently working as Assistant Professor in Holy Mary Institute of Technology & Science ,Bogaram, R.R. Dist, Hyderabad, Andhra Pradesh, India in the Dept. of Electrical & Electronics Engg. My Interest areas are Power electronics, FACTS, etc.



**S.RadhaKrishna Reddy** received the B.Tech. degree in Electrical & Electronics Engineering from MITS Engineering Madanapalle, Chittoor(Dt), Andhra Pradesh, India, from JNTU University and M.Tech. in Power Electronics from S.K. University in the year 2007. I have teaching experience of nearly 06 years &. Currently working as Associate Professor in Holy Mary Institute of Technology & Science ,Bogaram, R.R. Dist, Hyderabad, Andhra Pradesh, India in the Dept. of Electrical & Electronics Engg. My Interest areas are neural networks, Power electronics & Drives, FACTS, etc.



**Y.NARESH KUMAR** received the B.Tech. degree in Electrical & Electronics Engineering from Dr.Paul Raj Engineering College, Bhadrachalam, Khammam(Dt), Andhra Pradesh, India, from JNTU University and M.Tech. in Electrical Power Engineering (EPE) from Jawaharlal Nehru Technological University of Hyderabad(JNTUH) in the year 2011. And having the teaching experience of Five years & currently working as "Assistant Professor" in Holy Mary Institute of Technology & Science (HITS) in the Dept. of Electrical & Electronics Engineering (EEE), Bogaram (V), R.R.Dist, Hyderabad, Andhra Pradesh, India. Attended for the Several Workshops related to Electrical Conducted in different Colleges and Universities. Giving Guidance for the Project works of B.Tech and as well as M.Tech Students. My Interest areas are Artificial Neural Networks (ANN), Power System, FACTS, Fuzzy Logic (FL) and Power Quality(PQ) etc..



**CH.KAMAL** received the B.Tech Degree in EEE from HITS ENGG College, Bogaram, R.R. Dist, Hyderabad, Andhra Pradesh, India, from JNTU University and M.Tech. in ELECTRICAL POWER SYSTEMS from HITS ENGG College in the year 2012. I have teaching experience of nearly 03 years & Currently working as Assistant Professor in Holy Mary Institute of Technology & Science ,Bogaram, R.R. Dist, Hyderabad, Andhra Pradesh, India in the Dept. of Electrical & Electronics Engg. My Interest areas are neural networks, Power Systems, FACTS, etc.